

Access Integration Services



# Protocol Configuration and Monitoring Reference Volume 2 Version 3.2



Access Integration Services



# Protocol Configuration and Monitoring Reference Volume 2 Version 3.2

**Note**

Before using this document, read the general information under "Notices" on page xv.

**First Edition (November 1998)**

This edition applies to Version 3.2 of the IBM Access Integration Services and to all subsequent releases and modifications until otherwise indicated in new editions or technical newsletters.

Order publications through your IBM representative or the IBM branch office serving your locality. Publications are not stocked at the address below.

IBM welcomes your comments. A form for readers' comments is provided at the back of this publication. If the form has been removed, you may address your comments to:

Department CGF  
Design & Information Development  
IBM Corporation  
P.O. Box 12195  
RESEARCH TRIANGLE PARK NC 27709  
USA

When you send information to IBM, you grant IBM a non-exclusive right to use or distribute the information in any way it believes appropriate without incurring any obligation to you.

© **Copyright International Business Machines Corporation 1997, 1998. All rights reserved.**

Note to U.S. Government Users — Documentation related to restricted rights — Use, duplication or disclosure is subject to restrictions set forth in GSA ADP Schedule Contract with IBM Corp.

---

# Contents

<b>Figures</b> . . . . .	xi
<b>Tables</b> . . . . .	xiii
<b>Notices</b> . . . . .	xv
<b>Notice to Users of Online Versions of This Book</b> . . . . .	xvii
<b>Trademarks</b> . . . . .	xix
About the Software . . . . .	xxi
Conventions Used in This Manual . . . . .	xxii
Library Overview . . . . .	xxii
Summary of Changes for the IBM 2212 Software Library . . . . .	xxiv
Getting Help . . . . .	xxvi
Exiting a Lower Level Environment . . . . .	xxvi
<b>Chapter 1. APPN</b> . . . . .	1
What is APPN? . . . . .	1
Peer-to-Peer Communications . . . . .	1
APPN Node Types . . . . .	1
What APPN Functions Are Implemented on the Router? . . . . .	3
APPN Network Node Optional Features . . . . .	6
High-Performance Routing . . . . .	6
Dependent LU Requester (DLUR) . . . . .	8
APPN Connection Network . . . . .	12
Branch Extender . . . . .	13
Extended Border Nodes . . . . .	14
Branch Extender vs. Extended Border Node. . . . .	16
Managing a Network Node . . . . .	17
Entry Point Capabilities for APPN-related Alerts . . . . .	17
SNMP Capabilities for APPN MIBs . . . . .	19
Topology Database Garbage Collection . . . . .	19
Configurable Held Alert Queue. . . . .	19
Implicit Focal Point . . . . .	19
Dynamic Definition of Dependent (DDD) LUs . . . . .	20
TN3270E Server . . . . .	20
Support for Subarea SNA Connections from the TN3270E Server to the Host . . . . .	24
Enterprise Extender Support for HPR over IP . . . . .	25
Supported DLCs . . . . .	25
Router Configuration Process . . . . .	25
Configuration Changes That Require the APPN Function to Restart . . . . .	26
Configuration Requirements for APPN . . . . .	26
Configuring the Router as an APPN Network Node . . . . .	27
Configuring Branch Extender . . . . .	30
Configuring Extended Border Nodes. . . . .	31
High-Performance Routing . . . . .	36
DLUR . . . . .	36
Configuring Focal Points . . . . .	36
Configuring Held Alert Queue Size . . . . .	36
Defining Transmission Group (TG) Characteristics . . . . .	37
Calculating APPN Routes Using TG Characteristics . . . . .	37
COS Options . . . . .	38

APPN Node Tuning . . . . .	39
Node Service (Traces). . . . .	39
APPN Trace Enhancements. . . . .	40
Accounting and Node Statistics . . . . .	40
DLUR Retry Algorithm . . . . .	41
APPN Implementation on the Router Using DLSw . . . . .	43
APPN Frame Relay BAN Connection Network Implementation . . . . .	44
Port Level Parameter Lists . . . . .	48
Link Level Parameter Lists . . . . .	48
LU Parameter List . . . . .	48
Node Level Parameter Lists. . . . .	48
APPN Configuration Notes . . . . .	49
Configuring a Permanent Circuit Using ISDN . . . . .	49
Configuring APPN Over Dial on Demand Circuits . . . . .	51
Configuring WAN Reroute . . . . .	54
Configuring WAN Restoral . . . . .	59
Configuring V.25bis . . . . .	60
Configuring APPN Using SDLC . . . . .	62
Configuring APPN Over X.25 . . . . .	67
Configuring APPN Over Frame Relay . . . . .	70
Configuring APPN Over Frame Relay BAN . . . . .	70
Configuring TN3270E Using DLUR . . . . .	71
Configuring TN3270E Using a Subarea Connection . . . . .	73
Configuring Enterprise Extender Support for HPR Over IP . . . . .	75
Configuring Connection Networks over HPR over IP. . . . .	76
Configuring an Extended Border Node . . . . .	76
<b>Chapter 2. Configuring and Monitoring APPN . . . . .</b>	<b>79</b>
Accessing the APPN Configuration Process . . . . .	79
APPN Configuration Command Summary. . . . .	79
APPN Configuration Command Detail . . . . .	81
Enable/Disable . . . . .	81
Set . . . . .	81
Add. . . . .	122
Delete. . . . .	173
List . . . . .	174
Activate_new_config . . . . .	174
TN3270E . . . . .	175
Monitoring APPN. . . . .	190
Accessing the APPN Monitoring Commands. . . . .	190
APPN Monitoring Commands . . . . .	191
Aping . . . . .	191
Dump . . . . .	192
List . . . . .	192
Memory . . . . .	193
Restart . . . . .	193
Stop . . . . .	193
TN3270E . . . . .	193
Transmit . . . . .	194
<b>Chapter 3. Using AppleTalk Phase 2 . . . . .</b>	<b>195</b>
Basic Configuration Procedures . . . . .	195
Enabling Router Parameters . . . . .	195
Setting Network Parameters. . . . .	195
AppleTalk over PPP. . . . .	196
AppleTalk 2 Zone Filters . . . . .	196

General Information . . . . .	196
Why ZoneName Filters? . . . . .	197
How Do You Add Filters? . . . . .	197
Sample Configuration Procedures . . . . .	198
<b>Chapter 4. Configuring and Monitoring AppleTalk Phase 2 . . . . .</b>	<b>203</b>
Accessing the AppleTalk Phase 2 Configuration Environment . . . . .	203
AppleTalk Phase 2 Configuration Commands . . . . .	203
Add. . . . .	204
Delete. . . . .	205
Disable . . . . .	206
Enable . . . . .	207
List . . . . .	208
Set . . . . .	209
Accessing the AppleTalk Phase 2 Monitoring Environment . . . . .	211
AppleTalk Phase 2 Monitoring Commands . . . . .	211
Atecho . . . . .	211
Cache. . . . .	212
Clear Counters . . . . .	213
Counters. . . . .	213
Dump . . . . .	213
Interface . . . . .	214
<b>Chapter 5. Using VINES. . . . .</b>	<b>215</b>
VINES Overview . . . . .	215
VINES Over Router Protocols and Interfaces . . . . .	215
Service and Client Nodes . . . . .	215
VINES Network Layer Protocols . . . . .	216
VINES Internet Protocol (VINES IP). . . . .	216
Routing Update Protocol (RTP) . . . . .	217
Internet Control Protocol (ICP). . . . .	220
VINES Address Resolution Protocol (VINES ARP) . . . . .	220
Basic Configuration Procedures . . . . .	221
Running Banyan VINES on the Bridging Router . . . . .	221
Running Banyan VINES over WAN Links . . . . .	222
<b>Chapter 6. Configuring and Monitoring VINES . . . . .</b>	<b>223</b>
Accessing the VINES Configuration Environment . . . . .	223
VINES Configuration Commands . . . . .	223
Add. . . . .	223
Delete. . . . .	224
Disable . . . . .	224
Enable . . . . .	224
List . . . . .	225
Set . . . . .	226
Accessing the VINES Monitoring Environment . . . . .	227
VINES Monitoring Commands . . . . .	227
Counters. . . . .	227
Dump . . . . .	228
Route . . . . .	230
<b>Chapter 7. Using DNA IV . . . . .</b>	<b>231</b>
DNA IV Overview . . . . .	231
DNA IV Terminology and Concepts . . . . .	232
Routing . . . . .	233
Routing Tables . . . . .	233

Area Routers . . . . .	234
Configuring Routing Parameters . . . . .	234
IBM's Implementation of DNA IV . . . . .	234
Managing Traffic Using Access Control. . . . .	235
Managing Traffic Using Area Routing Filters . . . . .	238
Configuring DNA IV . . . . .	243
<b>Chapter 8. Configuring and Monitoring DNA IV . . . . .</b>	<b>247</b>
DNA IV Configuration and Monitoring Commands . . . . .	247
Define/Set . . . . .	248
Purge . . . . .	256
Set . . . . .	256
Show . . . . .	256
Show/List . . . . .	259
Zero . . . . .	265
<b>Chapter 9. Using OSI/DECnet V. . . . .</b>	<b>267</b>
OSI Overview . . . . .	267
NSAP Addressing . . . . .	268
IDP. . . . .	268
DSP . . . . .	269
IS-IS Addressing Format . . . . .	269
GOSIP Version 2 NSAPs. . . . .	270
Multicast Addresses. . . . .	270
OSI Routing . . . . .	271
IS-IS Protocol . . . . .	271
IS-IS Areas . . . . .	271
IS-IS Domain . . . . .	272
IS to IS Hello (IIH) Message . . . . .	274
L1 IIH Message . . . . .	274
L2 IIH Message . . . . .	275
Point-to-Point IIH Message . . . . .	275
Designated IS . . . . .	275
Link State Databases . . . . .	276
Routing Tables . . . . .	277
Address Prefix Encoding . . . . .	279
Authentication Passwords . . . . .	280
ESIS Protocol . . . . .	281
Hello Message . . . . .	281
End System Hello (ESH) Message . . . . .	281
Intermediate System Hello (ISH) Messages . . . . .	281
X.25 Circuits for DECnet V/OSI . . . . .	281
Routing Circuits . . . . .	282
Filters . . . . .	282
Templates . . . . .	283
Link Initialization . . . . .	283
OSI/DECnet V Configuration . . . . .	283
Basic Configuration Procedure. . . . .	283
Configuring OSI Over an Ethernet or a Token-Ring LAN . . . . .	284
Configuring OSI Over X.25 or Frame Relay . . . . .	284
Configuring a DNA V Router for a DNA IV Environment . . . . .	284
DNA IV and DNA V Algorithm Considerations . . . . .	285
<b>Chapter 10. Configuring and Monitoring OSI/DECnet V . . . . .</b>	<b>287</b>
Accessing the OSI Configuration Environment . . . . .	287
DECnet V/OSI Configuration Commands . . . . .	287



Add. . . . .	287
Change . . . . .	293
Clear . . . . .	295
Delete. . . . .	296
Disable . . . . .	298
Enable . . . . .	299
List . . . . .	299
Set . . . . .	305
Accessing the OSI/DECnet V Monitoring Environment . . . . .	311
OSI/DECnet V Monitoring Commands . . . . .	311
Addresses . . . . .	312
Change Metric. . . . .	313
CLNP-Stats. . . . .	313
Designated-router . . . . .	315
DNAV-info . . . . .	315
ES-Adjacencies . . . . .	316
ES-IS-Stats . . . . .	316
IS-Adjacencies . . . . .	318
IS-IS-Stats . . . . .	318
L1-Routes . . . . .	320
L2-Routes . . . . .	320
L1-Summary . . . . .	321
L2-Summary . . . . .	322
L1-Update . . . . .	322
L2-Update . . . . .	323
Ping-1139 . . . . .	323
Route . . . . .	324
Send (Echo Packet). . . . .	324
Subnets . . . . .	325
Toggle (Alias/No Alias). . . . .	325
Traceroute . . . . .	325
<b>Chapter 11. Using IP Version 6 (IPv6) . . . . .</b>	<b>327</b>
IPv6 Overview. . . . .	327
IPv6 Comparison with IPv4 . . . . .	327
IPv6 Addressing . . . . .	327
IPv6 Address Format . . . . .	328
Text Representation of Address Prefixes . . . . .	328
IPv6 Header Format . . . . .	328
IPv6 Minimum MTU. . . . .	329
IPv6 Mandatory Path MTU Discovery . . . . .	329
IPv6 Mandatory Security . . . . .	329
IPv6 Neighbor Discovery Protocol (NDP) . . . . .	330
Router and Prefix Discovery. . . . .	330
Address Autoconfiguration . . . . .	330
Address Resolution . . . . .	330
Neighbor Unreachability Detection . . . . .	330
Redirect . . . . .	330
IPv6 over IPv4 Tunneling. . . . .	331
Protocol Independent Multicast (PIM) . . . . .	331
<b>Chapter 12. Configuring and Monitoring IPV6 . . . . .</b>	<b>333</b>
Accessing the IPV6 Configuration Environment. . . . .	333
IPV6 Configuration Commands . . . . .	333
Add. . . . .	333
Change . . . . .	337

Delete . . . . .	337
Disable . . . . .	338
Enable . . . . .	338
List . . . . .	339
Set . . . . .	341
Update . . . . .	344
Update Packet-filter Commands . . . . .	344
Accessing the IPV6 Monitoring Environment. . . . .	347
IPV6 Monitoring Commands. . . . .	348
Cache . . . . .	348
Counters . . . . .	348
Dump routing tables . . . . .	349
Interface addresses . . . . .	349
Mcast . . . . .	349
Mld . . . . .	350
Route . . . . .	350
Sizes . . . . .	350
Static routes . . . . .	351
Packet-filter . . . . .	351
Path-mtu . . . . .	351
Ping6 . . . . .	351
Traceroute6. . . . .	352
Tunnels . . . . .	353

**Chapter 13. Configuring and Monitoring Neighbor Discovery Protocol (NDP)** . . . . . 355

Accessing the NDP Configuration Environment. . . . .	355
NDP Configuration Commands. . . . .	355
Add. . . . .	355
Change . . . . .	357
Delete. . . . .	358
Disable . . . . .	359
Enable . . . . .	359
List . . . . .	359
Accessing the NDP Monitoring Environment. . . . .	359
NDP Monitoring Commands. . . . .	360
Dump . . . . .	360
Ping6 . . . . .	360
List . . . . .	360

**Chapter 14. Configuring and Monitoring Protocol Independent Multicast Routing Protocol (PIM)** . . . . . 361

Accessing the PIM Configuration Environment . . . . .	361
PIM Configuration Commands . . . . .	361
Delete. . . . .	361
Disable . . . . .	362
Enable . . . . .	362
List . . . . .	362
Set . . . . .	363
Accessing the PIM Monitoring Environment . . . . .	365
PIM Monitoring Commands . . . . .	366
Dump routing tables . . . . .	366
Clear . . . . .	366
Interface . . . . .	367
Join . . . . .	367
Leave . . . . .	368

Mcache . . . . .	368
Mgroup . . . . .	368
Mstats. . . . .	369
Neighbor. . . . .	370
PIM. . . . .	371
Summary PIM. . . . .	372
Ping . . . . .	372
Traceroute . . . . .	372
Variables. . . . .	373
<b>Chapter 15. Configuring and Monitoring Routing Information Protocol (RIP6)</b> . . . . .	375
Accessing the RIP6 Configuration Environment . . . . .	375
RIP6 Configuration Commands . . . . .	375
Add. . . . .	375
Change . . . . .	376
Delete. . . . .	377
Disable . . . . .	377
Enable . . . . .	378
List . . . . .	380
Set . . . . .	380
Accessing the RIP6 Monitoring Environment. . . . .	381
RIP6 Monitoring Commands . . . . .	381
List . . . . .	381
Dump . . . . .	381
Ping6 . . . . .	382
<b>Appendix. Packet Sizes</b> . . . . .	383
General Issues . . . . .	383
Network-Specific Size Limits . . . . .	383
Protocol-Specific Size Limits . . . . .	384
IP Packet Lengths . . . . .	384
Changing Maximum Packet Sizes . . . . .	384
<b>List of Abbreviations</b> . . . . .	385
<b>Glossary</b> . . . . .	395
<b>Index</b> . . . . .	419
<b>Readers' Comments — We'd Like to Hear from You.</b> . . . . .	427



---

# Figures

1. Extended Border Node Connectivity . . . . .	15
2. Multiple PUs for Subarea Connected SNA Nodes . . . . .	24
3. Data Flow in an APPN Configuration Using DLSw Port . . . . .	43
4. Logical View with Frame Relay Bridged Frame/BAN Connection Network Support . . . . .	44
5. APPN Frame Relay Bridged Frame/BAN Connection Network . . . . .	45
6. Single Connection Network using BAN with 1 Frame Relay Port . . . . .	45
7. Single Connection Network using BAN with Multiple Frame Relay Ports . . . . .	46
8. Multiple Connection Networks using BAN . . . . .	46
9. Single Connection Network using Bridging with One Frame Relay Port . . . . .	47
10. Single Connection Network Using Bridging with Multiple Frame Relay Ports . . . . .	47
11. Multiple Connection Networks Using Bridging . . . . .	47
12. Example of Zone Filtering. . . . .	199
13. Example of Network Filtering . . . . .	201
14. Sample Routing Table . . . . .	218
15. Sample Neighbor Table . . . . .	219
16. Example of Inclusive Access Control. . . . .	237
17. Example of Exclusive Access Control . . . . .	238
18. Example of Area Routing Filter for Security . . . . .	240
19. Example of Blending DECnet Domains . . . . .	242
20. OSI Network . . . . .	267
21. NSAP Address Structure . . . . .	268
22. IS-IS NSAP Addressing Interpretation . . . . .	269
23. GOSIP Address Format . . . . .	270
24. OSI Domain. . . . .	273
25. Synonymous Areas . . . . .	274
26. Internal and External Routing Metrics . . . . .	279



## Tables

1. Implementation of APPN Network Node Functions. . . . .	3
2. Port Types Supported for APPN Routing . . . . .	25
3. APPN Configuration Command Summary . . . . .	79
4. Configuration Parameter List - APPN Routing . . . . .	81
5. Configuration Parameter List - High-Performance Routing (HPR) . . . . .	86
6. Configuration Parameter List - HPR Timer and Retry Options . . . . .	86
7. Configuration Parameter List - Dependent LU Requester . . . . .	89
8. Configuration Parameter List - APPN Node Tuning . . . . .	94
9. Configuration Parameter List - Trace Setup Questions . . . . .	99
10. Configuration Parameter List - Node Level Traces. . . . .	100
11. Configuration Parameter List - Inter-process Signals Traces . . . . .	105
12. Configuration Parameter List - Module Entry and Exit Traces. . . . .	109
13. Configuration Parameter List - General Component Level Traces . . . . .	111
14. Configuration Parameter List - Miscellaneous Traces. . . . .	116
15. Configuration Parameter List - APPN Node Management . . . . .	118
16. Configuration Parameter List - APPN ISR Recording Media . . . . .	120
17. Configuration Parameter List - Port Configuration . . . . .	122
18. Configuration Parameter List - Port Definition . . . . .	127
19. Configuration Parameter List - Port Default TG Characteristics . . . . .	132
20. Configuration Parameter List - Port default LLC Characteristics . . . . .	137
21. Configuration Parameter List - HPR Override Defaults . . . . .	139
22. Configuration Parameter List - Link Station - Detail . . . . .	140
23. Configuration Parameter List - Modify TG Characteristics . . . . .	150
24. Configuration Parameter List - Modify Dependent LU Server . . . . .	153
25. Configuration Parameter List - Modify LLC Characteristics. . . . .	154
26. Configuration Parameter List - Modify HPR Defaults . . . . .	156
27. Configuration Parameter List - LEN End Node LU Name . . . . .	157
28. Configuration Parameter List - Connection Network - Detail . . . . .	158
29. Configuration Parameter List - TG Characteristics (Connection Network) . . . . .	161
30. Configuration Parameter List - APPN COS - Mode Name to COS Name Mapping - Detail . . . . .	164
31. Configuration Parameter List - APPN Additional port to Connection Network . . . . .	166
32. Configuration Parameter List - APPN Implicit Focal Point . . . . .	167
33. Configuration Parameter List - APPN Local PU . . . . .	167
34. Configuration Parameter List - Routing List Configuration . . . . .	169
35. Configuration Parameter List - COS Mapping Table Configuration . . . . .	172
36. TN3270E Configuration Command Summary . . . . .	175
37. Configuration Parameter List - Set TN3270E . . . . .	175
38. Configuration Parameter List - Add TN3270E Implicit. . . . .	178
39. Configuration Parameter List - Add TN3270E LU . . . . .	181
40. Configuration Parameter List - Add TN3270E Map. . . . .	185
41. Configuration Parameter List - Add TN3270E Port. . . . .	186
42. Configuration Parameter List - Delete TN3270E LU . . . . .	187
43. Configuration Parameter List - Delete TN3270E Implicit. . . . .	187
44. Configuration Parameter List - Delete TN3270E Map. . . . .	188
45. Configuration Parameter List - Delete TN3270E Port. . . . .	190
46. APPN Monitoring Command Summary . . . . .	191
47. TN3270E Monitoring Command Summary. . . . .	193
48. AppleTalk Phase 2 Configuration Commands Summary. . . . .	203
49. AppleTalk Phase 2 Monitoring Command Summary . . . . .	211
50. Vines IP Header Fields Summary . . . . .	217
51. Client and Service Node VINES ARP States . . . . .	221

52.	VINES Configuration Commands Summary . . . . .	223
53.	VINES Monitoring Command Summary. . . . .	227
54.	DNA IV and DNA V Algorithm Considerations . . . . .	243
55.	NCP Configuration and Monitoring Commands . . . . .	247
56.	IS-IS Multicast Addresses. . . . .	270
57.	OSI Configuration Commands Summary . . . . .	287
58.	OSI/DECnet V Monitoring Commands Summary . . . . .	312
59.	IPV6 Configuration Command Summary . . . . .	333
60.	Update Packet-filter Configuration Command Summary. . . . .	344
61.	IPv6 Monitoring Command Summary . . . . .	348
62.	NDP Configuration Command Summary . . . . .	355
63.	NDP Monitoring Command Summary . . . . .	360
64.	PIM Configuration Command Summary. . . . .	361
65.	PIM Monitoring Command Summary. . . . .	366
66.	RIP6 Configuration Command Summary . . . . .	375
67.	RIP6 Monitoring Command Summary . . . . .	381
68.	Default Network-Specific Maximum Packet Size . . . . .	383



---

## Notices

References in this publication to IBM products, programs, or services do not imply that IBM intends to make these available in all countries in which IBM operates. Any reference to an IBM product, program, or service is not intended to state or imply that only IBM's product, program, or service may be used. Any functionally equivalent product, program, or service that does not infringe any of IBM's intellectual property rights may be used instead of the IBM product, program, or service. Evaluation and verification of operation in conjunction with other products, except those expressly designated by IBM, are the user's responsibility.

| IBM may have patents or pending patent applications covering subject matter in this  
| document. The furnishing of this document does not give you any license to these  
| patents. You can send license inquiries, in writing, to the IBM Director of Licensing,  
| IBM Corporation, North Castle Drive, Armonk, NY 10504-1785, U.S.A.

The licensed program described in this document and all licensed material available for it are provided by IBM under terms of the IBM Customer Agreement.

| This document is not intended for production use and is furnished as is without any  
| warranty of any kind, and all warranties are hereby disclaimed including the  
| warranties of merchantability and fitness for a particular purpose.



---

## Notice to Users of Online Versions of This Book

For online versions of this book, you are authorized to:

- Copy, modify, and print the documentation contained on the media, for use within your enterprise, provided you reproduce the copyright notice, all warning statements, and other required statements on each copy or partial copy.
- Transfer the original unaltered copy of the documentation when you transfer the related IBM product (which may be either machines you own, or programs, if the program's license terms permit a transfer). You must, at the same time, destroy all other copies of the documentation.

You are responsible for payment of any taxes, including personal property taxes, resulting from this authorization.

THERE ARE NO WARRANTIES, EXPRESS OR IMPLIED, INCLUDING THE WARRANTIES OF MERCHANTABILITY AND FITNESS FOR A PARTICULAR PURPOSE.

Some jurisdictions do not allow the exclusion of implied warranties, so the above exclusion may not apply to you.

Your failure to comply with the terms above terminates this authorization. Upon termination, you must destroy your machine-readable documentation.



---

## Trademarks

The following terms are trademarks of the IBM Corporation in the United States or other countries or both:

Advanced Peer-to-Peer Networking	IBM	PS/2
AIX	Micro Channel	RS/6000
AIXwindows	NetView	System/370
APPN	AS/400	Nways
VTAM	BookManager	

UNIX is a registered trademark in the United States and other countries licensed exclusively through X/Open Company Limited.

Microsoft, Windows, Windows NT, and the Windows logo are trademarks or registered trademarks of Microsoft Corporation.

Other company, product, and service names may be trademarks or service marks of others.



—

This manual contains the information you will need to configure bridging and routing functions on an IBM 2212. The manual describes all of the features and functions that are in the software. A specific IBM 2212 might not support all of the features and functions described. If a feature or function is device-specific, a notice in the relevant chapter or section indicates that restriction.

This manual supports the IBM 2212 and refers to this product as either “the router” or “the device.” The examples in the manual represent the configuration of an IBM 2212 but the actual output you see may vary. Use the examples as a guideline to what you might see while configuring your device.

**Who Should Read This Manual:** This manual is intended for persons who install and operate computer networks. Although experience with computer networking hardware and software is helpful, you do not need programming experience to use the protocol software.

**To get additional information:** Changes may be made to the documentation after the books are printed. If additional information is available or if changes are required after the books have been printed, the changes will be in a file (named README) on diskette 1 of the configuration program diskettes. You can view the file with an ASCII text editor.

---

## About the Software

IBM Access Integration Services is the software that supports the IBM 2212 (licensed program number 5639-F73). This software has these components:

- The base code, which consists of:
  - The code that provides the routing, bridging, data link switching, and SNMP agent functions for the device.
  - The router user interface, which allows you to configure, monitor, and use the Access Integration Services base code installed on the device. The router user interface is accessed locally through an ASCII terminal or emulator attached to the service port, or remotely through a Telnet session or modem-attached device.

The base code is installed at the factory on the 2212.

- The Configuration Program for IBM Access Integration Services (referred to in this book as the *Configuration Program*) is a graphical user interface that enables you to configure the device from a stand-alone workstation. The Configuration Program includes error checking and online help information.

The Configuration Program is not pre-loaded at the factory; it is shipped separately from the device as part of the software order.

You can also obtain the Configuration Program for IBM Access Integration Services from the IBM Networking Technical Support home page. See *Configuration Program User's Guide for Multiprotocol and Access Services Products*, GC30-3830, for the server address and directories.

---

## Conventions Used in This Manual

The following conventions are used in this manual to show command syntax and program responses:

1. The abbreviated form of a command is underlined as shown in the following example:

```
reload
```

In this example, you can enter either the whole command (reload) or its abbreviation (rel).

2. Keyword choices for a parameter are enclosed in brackets and separated by the word or. For example:

```
command [keyword1 or keyword2]
```

Choose one of the keywords as a value for the parameter.

3. Three periods following an option mean that you enter additional data (for example, a variable) after the option. For example:

```
time host ...
```

In this example, you enter the IP address of the host in place of the periods, as explained in the description of the command.

4. In information displayed in response to a command, defaults for an option are enclosed in brackets immediately following the option. For example:

```
Media (UTP/STP) [UTP]
```

In this example, the media defaults to UTP unless you specify STP.

5. Keyboard key combinations are indicated in text in the following ways:

- **Ctrl-P**
- **Ctrl -**

The key combination **Ctrl -** indicates that you should press the Ctrl key and the hyphen simultaneously. In certain circumstances, this key combination changes the command line prompt.

6. Names of keyboard keys are indicated like this: **Enter**
7. Variables (that is, names used to represent data that you define) are denoted by italics. For example:

```
File Name: filename.ext
```

---

## Library Overview

The following list shows the books in the IBM 2212 library, arranged according to tasks.

**Information updates and corrections:** To keep you informed of engineering changes, clarifications, and fixes that were implemented after the books were printed, refer to the IBM 2212 home pages at:

<http://www.networking.ibm.com/2212/2212prod.html>

### Planning

#### GA27-4215

*IBM 2212 Introduction and Planning Guide*



This book is shipped with the IBM 2212. It explains how to prepare for installation and perform an initial configuration.

## **Installation**

### **GA27-4216**

*IBM 2212 Access Utility Installation and Initial Configuration Guide*

This booklet is shipped with the IBM 2212. It explains how to install the IBM 2212 and verify its installation.

### **GX27-4048**

*2212 Hardware Configuration Quick Reference*

This reference card is used for entering and saving hardware configuration information used to determine the correct state of an IBM 2212.

## **Diagnostics and Maintenance**

### **GY27-0362**

*IBM 2212 Access Utility Service and Maintenance Manual*

This book is shipped with the IBM 2212. It provides instructions for diagnosing problems with and repairing the IBM 2212.

## **Operations and Network Management**

The following list shows the books that support the Access Integration Services program.

### **SC30-3988**

*Software User's Guide*

This book explains how to:

- Configure, monitor, and use the Access Integration Services software.
- Use the Access Integration Services command-line router user interface to configure and monitor the network interfaces and link-layer protocols shipped with the IBM 2212.

### **SC30-3989**

*Using and Configuring Features*

### **SC30-3990**

*Protocol Configuration and Monitoring Reference Volume 1*

### **SC30-3991**

*Protocol Configuration and Monitoring Reference Volume 2*

These books describe how to access and use the Access Integration Services command-line user interface to configure and monitor the routing protocol software shipped with the product.

They include information about each of the protocols that the devices support.

### **SC30-3682**

*Event Logging System Messages Guide*

This book contains a listing of the error codes that can occur, along with descriptions and recommended actions to correct the errors.

## **Configuration**

### **GC30-3830**

*Configuration Program User's Guide for Multiprotocol and Access Services Products*

This book discusses how to use the Configuration Program.

### **Safety**

#### **SD21-0030**

*Caution: Safety Information—Read This First*

This book, shipped with the IBM 2212, provides translations of caution and danger notices applicable to the installation and maintenance of a IBM 2212.

### **Marketing**

URL: <http://www.networking.ibm.com/2212/2212prod.html>

This IBM Web page provides product information through the World Wide Web.

---

## **Summary of Changes for the IBM 2212 Software Library**

The IBM 2212 is a new product; however, it uses common code. The following list applies to changes in the common code that were made in Version 3.2.

#### **• New functions:**

- IP Version 6
  - TCP6, UDP6, Telnet, PING-6 and traceroute-6, ICMPv6, and IPsec
  - Neighbor discovery protocol (NDP) for host auto-configuration
  - Static routes, RIPng, Protocol Independent Multicast-Dense Mode (PIM-DM), and Multicast Listener Discovery (MLD)
  - Configured or automatic tunneling of IPv6 packets over IPv4 networks
- Resource ReSerVation Protocol (RSVP)
  - Signalling mechanisms that enable applications on IPv4 networks to reserve network resources to achieve a desired quality of service for packet delivery
- Thin Server Support
  - Acts as boot server for network stations
  - Servers supported include Network Station Manager (NSM) R2.5 and 3.0 on OS/400 and NSM R3.0 for NFS servers such as Windows NT, OS/390, AIX, and VM
- Binary Synchronous Relay (BRLY) support for BSC interfaces
  - Binary Synchronous Relay (BRLY) support for tunneling Bisync Synchronous (BSC) transmissions over a IPv4 network to a partner 2210 or 2212 router

#### **• Enhanced functions:**

- Base Services
  - Event Logging System (ELS) enhancements to capture, format, and offload large volumes of ELS messages
  - Support for maintaining multiple, compressed dump files
  - Timed configuration change support from the configuration tool that is persistent across reloads and restarts

## Summary of Changes

- Packet trace support for PPP, Frame Relay, and V.34 interfaces.
- Bridging support for a multiaccess bridge port for source route bridging over Frame Relay. The multiaccess port incorporates many DLCIs in a single bridge port for improved scalability.
- DIALs
  - DIALs support for functions supported by Microsoft Dial-Up Network Clients
    - Support for Callback Control Protocol (CBCP)
    - Support for Microsoft Point-to-Point Encryption (MPPE) and Microsoft PPP CHAP (MS-CHAP)
  - Virtual connections to suspend and resume dial-up connections when Shiva Password Authentication Protocol (SPAP) is used
- IP items
  - IP precedence/TOS filter enhancements
  - Policy-based routing
  - Configuration of the IP MTU by interface
  - OSPF Enhancements to allow for easier migration of IBM 6611 router networks
  - BGP-4 support for policies per neighbor and additional attributes for path selection
  - DVMRPv3 support
  - IGMP prune and grafting support
- ISDN support for callback based on the caller ID and call blocking
- L2TP support for the L2TP client model which allows the 2212 to create an L2TP tunnel between itself and another router. The tunnel can be used for any traffic entering the 2212. The L2TP Network Server (LNS) function has also been enhanced to initiate outgoing calls to the L2TP Network Access Concentrator (LAC).
- Network Dispatcher items
  - Support for stateless UDP applications
  - New protocol advisors for Network News Transfer Protocol (NNTP), Post Office Protocol (POP3), Simple Mail Transfer Protocol (SMTP), and Telnet
  - While you are balancing TN3270 servers, one of the TN3270 servers may be in the same 2212 as the Network Dispatcher function
- Support for PPP authentication using an ACE/Server
- Security Enhancements
  - IPsec tunnel-in-tunnel support for creating up to two nested levels of security associations
  - IPsec ESP NULL algorithm support
  - IPsec support for setting the *don't fragment* bit and propagation of Path MTU
  - Improved dynamic reconfiguration for IPsec
- Mixed media multi-link PPP support for bundling PPP leased line, ISDN, V.25bis, and V.34 connections
- APPN enhancements
  - APPN SDLC Secondary multipoint support
  - Configuration of the APPN transmission group (TG) number for all link station types
  - Support for the APPN Ping (APING) command in Talk 5

## Summary of Changes

- New trace options
- TN3270 Enhancements

**Note:** These TN3270 enhancements will not be available in the initial release of V3.2, but will be available on the 2212 Web server by 12/31/98.

- TN3270 LU pooling support that allows SNA LUs to be grouped into named pools
- TN3270 IP address to LU name mapping
- Self-Defining Dependent LUs (SDDL) and Dynamically Defined Dependent LUs (DDL) support
- Multiple TCP port support
- DLSw enhancements
  - Support for duplicate MAC addresses
  - Support to delay polling of SDLC devices until contacted by the remote SDLC device
- X.25 enhancements
  - Configuration support for defining a range of PVCs
  - Support for up to 2500 PVCs
- Frame Relay support for switched virtual circuits
- IPXWAN support on Frame Relay permanent virtual circuits (PVCs), including support for numbered RIP, unnumbered RIP, and static routing

- **Clarifications and corrections**

The technical changes and additions are indicated by a vertical line (|) to the left of the change.

---

## Getting Help

At the command prompts, you can obtain help in the form of a listing of the commands available at that level. To do this, type ? (the **help** command), and then press **Enter**. Use ? to list the commands that are available from the current level. You can usually enter a ? after a specific command name to list its options. For example, the following information appears if you enter ? at the \* prompt:

```
*?  
  
DIAGS hardware diagnostics  
DIVERT output from process  
FLUSH output from process  
HALT output from process  
INTERCEPT character is  
LOGOUT  
MEMORY statistics  
RELOAD  
RESTART  
  
STATUS of process(es)  
TALK to process  
TELNET to IP-Address
```

---

## Exiting a Lower Level Environment

The multiple-level nature of the software places you in secondary, tertiary, and even lower level environments as you configure or operate the 2212. To return to the next higher level, enter the **exit** command. To get to the secondary level, continue entering **exit** until you receive the secondary level prompt (either Config> or +).

## Summary of Changes

For example, to exit the IP protocol configuration process:

```
IP config> exit  
Config>
```

If you need to get to the primary level (OPCON), enter the intercept character (**Ctrl P** by default).

## Summary of Changes

---

## Chapter 1. APPN

This chapter describes APPN and includes the following sections:

- “What is APPN?”
- “What APPN Functions Are Implemented on the Router?” on page 3
- “APPN Network Node Optional Features” on page 6
- “Supported DLCs” on page 25
- “Router Configuration Process” on page 25
- “APPN Configuration Notes” on page 49

---

### What is APPN?

Advanced Peer-to-Peer networking (APPN) extends the SNA architecture by enabling Type 2.1 (T2.1) nodes to communicate directly without requiring the services of a SNA host computer.

### Peer-to-Peer Communications

T2.1 nodes can activate connections with other T2.1 nodes and establish LU-LU sessions with other nodes. The relationship between a pair of T2.1 nodes is referred to as a *peer relationship* because either side can initiate communication.

Prior to APPN, a T2.1 node could communicate directly with another T2.1 node, but required the services of a centralized SNA host to locate its partner and any associated resources. All routes between the two nodes were predefined. APPN enhanced the T2.1 node function by:

- Requiring network resources to be defined only at the node where they are located
- Distributing information about these resources throughout the network as needed
- Dynamically generating routes between nodes using current information about the network’s topology and the desired class of service

### APPN Node Types

The APPN architecture allows four types of nodes in a network:

- APPN network nodes
- APPN end nodes
- Low-entry networking (LEN) end nodes
- PU 2.0 nodes supported by DLUR

The router can be configured as an APPN network node that supports connections with all four node types. The router cannot function as an end node for APPN.

#### APPN Network Node

An APPN network node provides directory and routing services for all resources (LUs) in its domain. A network node’s domain consists of:

- Local resources owned by the node

## APPN

- A control point (CP), which manages the node's resources
- Resources owned by APPN end nodes and LEN end nodes that use the services of the network node

APPN network nodes also:

- Exchange information about the topology of the network. This information is exchanged each time network nodes establish a connection or when there is a change in the topology of the network (such as when a network node is deactivated, brought on line, or when a link is congested or fails). When a network node receives a topology update, it broadcasts this information to other active and network nodes with which it has CP-CP sessions.
- Act as intermediate nodes, receiving session data from one adjacent node and passing that data on to the next adjacent node along the route.

As a network node, the router can act as a server to attached APPN end nodes and LEN end nodes and provide functions that include:

### Directory services

The network node, communicating with other network nodes, can locate a resource in the network on behalf of an APPN end node. The network node also maintains a local directory of APPN and LEN end node resources that it can search on behalf of an attached APPN end node, attached LEN end node, or other network nodes.

### Topology and Routing services

At the request of an APPN end node, the network node dynamically determines the route from an origin logical unit (LU) to a destination LU in the network. The network node also maintains information on other network nodes and the routes to those nodes. The route is based on the current topology of the network.

### Management services

The network node can pass *alert* conditions to a designated focal point to allow centralized problem management. The network node is responsible for processing alert conditions for all the resources in its domain. "Managing a Network Node" on page 17 describes this process.

## APPN End Nodes

An APPN end node provides limited directory, routing, and management services for logical units (LUs) associated with the node. An APPN end node selects a network node to be its network node server. If the network node agrees to act as the APPN end node's server, the end node can register its local resources with the network node. This enables the network node server to intercept and pass along search requests for resources located on the APPN end node.

The APPN end node and its network node server communicate by establishing CP-CP sessions. An APPN end node may be connected to a number of network nodes, but only one of these nodes acts as the APPN end node's server at any one time.

The APPN end node forwards all requests for unknown resources to the network node server. The network node server, in turn, uses its search facilities to locate the requested resource and calculate a route from the APPN end node to the resource.



## LEN Nodes

A LEN node is a T2.1 node without APPN extensions. A LEN node can establish peer connections with other LEN nodes, APPN end nodes, and APPN network nodes, as long as all of the required destination LUs are registered with the LEN node. A LEN node can also serve as a gateway between an APPN network and a SNA subarea network.

Because a LEN node cannot establish CP-CP sessions with an APPN network node server, it cannot register its resources with the server or request that the server search for a resource and dynamically calculate a route to that resource. A LEN node may indirectly use the directory and routing services of a network node by pre-defining remote LUs (owned by nonadjacent nodes) as being located on an APPN network node, although the actual location may be anywhere in the network. When the LEN node needs to initiate a session with the remote LU, it sends a session activation request (BIND) for the LU to the network node. In this case, the network node acts as the LEN node's network node server, locating the requested resource, calculating a route, and forwarding the BIND to its correct destination.

When configuring the router network node, you can specify the names of LUs that are associated with an attached LEN end node. These LU names reside in the router network node's local directory. If the router network node receives a request to search for one of these LEN end node resources, it will be able to find the LU in its local directory and return a positive response to the node originating the search. To reduce the number of LU names you need to specify for an attached LEN end node, the router supports the use of generic LU names, which allow a wildcard character to represent a portion of an LU name.

## PU 2.0 Nodes

A PU 2.0 node is a type T2.0 node containing dependent LUs. PU 2.0 nodes are supported by the Dependent LU Requestor (DLUR) function which is implemented by an APPN end node or network node. PU 2.0 nodes require the services of a system services control point, which is made available through the DLUR-enabled APPN node. Note that APPN nodes can contain dependent LUs supported by the DLUR function. However, the router does not contain dependent LUs.

## What APPN Functions Are Implemented on the Router?

The router implements the APPN Release 2 base architecture functions as defined in the Systems Network Architecture APPN Reference. The APPN network node functions implemented by the router are summarized in Table 1. Notes on specific functions follow the table. For a description of the APPN management services supported by the router, see "Managing a Network Node" on page 17.

APPN uses LU 6.2 protocols to provide peer connectivity between CP-CP session partners. The router network node implements the LU 6.2 protocols required for CP-CP sessions and those used in sessions between a network node CP and its network management focal point. The router implementation of APPN does not provide an application program interface to support user-written LU 6.2 programs.

*Table 1. Implementation of APPN Network Node Functions*

APPN Function	Yes	No	Notes
<b>Session services and supporting functions</b>			
Multiple CP-CP sessions	X		

## APPN

Table 1. Implementation of APPN Network Node Functions (continued)

APPN Function	Yes	No	Notes
Mode name to class of service (COS) mapping	X		1
Limited resource link stations	X		2
BIND segmentation and reassembly	X		3
Session-level security	X		4
<b>Intermediate session routing</b>			
Intermediate session routing	X		
Routing of dependent LU sessions	X		
Fixed and adaptive session-level pacing	X		
RU segmentation and reassembly	X		5
<b>Directory services</b>			
Broadcast searches	X		
Directed searches	X		
Directory caching	X		
Safe storage of directory services cache		X	6
Central directory server		X	7
Central directory client	X		7
Registration of APPN EN LUs with network node server	X		
Definition of LEN node LUs on network node server	X		
Use of wild cards to define attached LEN node resources	X		
Accept multiple "resource found" conditions	X		
Network node server for DLUR EN - Option set 1116	X		
<b>Topology and routing services</b>			
Topology exchange	X		
Periodic topology broadcasts	X		8
Topology database maintenance	X		9
Topology awareness of CP-CP sessions	X		
Randomized route computation	X		10
Cached routing trees	X		11
Safe storage of topology database	X		
Garbage Collection Enhancements	X		
<b>Connectivity</b>			
Connection network definition	X		12
Multiple transmission groups	X		
Parallel transmission groups	X		
<b>Management services</b>			
Multiple domain support (MDS)	X		
Explicit focal point	X		
Implicit focal point	X		
Held alerts	X		
SSCP-PU sessions with focal points		X	
SNA/MS problem diagnosis data in alerts	X		

### Notes:

1. New mode names can be defined on the router using the Command Line interface. These new mode names can be mapped to existing Class of Service (COS) definition names or to new COS definitions, which may be defined using the Configuration tool.
2. Limited resource link stations are supported for:
  - connection network links

- X.25 SVC links
  - PPP links running over ISDN, V.25bis, or V.34
  - Frame relay links running over ISDN
3. When the router activates a TG to an adjacent node, it negotiates with that node the maximum message size that can be sent across the TG. If a BIND message is larger than the negotiated message size, the router segments the BIND. Segmentation only occurs if the adjacent node is capable of reassembling the BIND. The router supports BIND reassembly.
  4. A session level security feature can be enabled for connections between the router network node and an adjacent node. Both partners in the connection require a matching hexadecimal key that enables each node to verify its partner before the connection is established.
  5. When routing session data to an adjacent node, the router segments a request/response unit (RU) if the message unit exceeds the maximum message size that can be sent across the transmission group. If the router receives a segmented RU, the node reassembles it.
  6. After successfully locating a resource in the APPN network, the router stores or *caches* this information in its local directory database for future use. However, the router does not save these cached directory entries to a permanent storage medium, such as a disk, to provide for recovery if the node fails.
  7. The router cannot be used as a central directory server for an APPN network. The router is capable of using a central directory server, however, to obtain directory information about the location of a resource in the network.
  8. To prevent other network nodes from discarding information about the router from their topology databases, the router creates a topology database update (TDU) about itself and its locally-owned transmission groups every 5 days and broadcasts this TDU to network nodes.
  9. An interval timer is associated with every resource entry in the router's network topology database. If the router does not receive any information about a resource within 15 days, it discards the entry for that resource from the database.
  10. If there is more than one least-weight route from an origin LU to a destination LU for a given class of service, the router randomly selects one of these routes for the session. This practice helps distribute the flow of traffic in the network.
  11. The router maintains a copy of the network topology database. The database identifies the available routes to other network nodes for a particular class of service. When the router needs to calculate a route to a network node or to an end node adjacent to that network node, it uses information in the topology database to generate a routing tree for that network node. The routing tree identifies the optimal routes to the network node for the class of service required.

When the router generates a new routing tree, it stores that tree in a cache. When the router receives a service request, it checks this cache first to see if a route has been computed. Use of the cache reduces the number of route calculations required. When the router receives topology information that invalidates a routing tree, it discards the tree. The router recalculates the tree as needed and caches the new tree.

12. The router can be defined as a member of a connection network on Ethernet ports, Token-Ring ports, Frame Relay BAN ports, and Enterprise Extender Support for HPR over IP.

---

## APPN Network Node Optional Features

In addition to the base APPN Architecture functions, the router also implements the following option set towers and new functions:

- 087** Garbage Collection Enhancements
- 1002** Adjacent Link Station name
- 1007** Parallel TGs
- 1012** LU name = CP name
- 1016** Extended Border Node
- 1061** Prerequisites for SS Extensions for NNS Support
- 1063** SS Extensions NNS Support
- 1067** Dependent LU Requester
- 1071** Generalized ODAI Usage
- 1101** Preloaded Directory Cache
- 1107** Central Resource Registration (of LUs)
- 1116** Network Node Server support for DLUS-Served LU registration
- 1119** Report Branch Topology to a Manager
- 1120** Branch Awareness
- 1121** Branch Extender
- 1200** Tree Caching and TG Caching
- 1201** Permanent Storage Medium
- 1400** High-Performance Routing (HPR)
- 1401** Rapid Transport Protocol (RTP)
- 1402** Control Flows over RTP
- 1405** HPR Border Node
  - Node performance tuning
  - Node service traces
  - Accounting and node statistics collection

## High-Performance Routing

HPR is an enhancement to APPN architecture that provides better performance over high speed, low error rate links using existing hardware. HPR replaces the normal APPN intermediate session routing (ISR) with a Network Control Layer (NCL) containing a new type of source routing function called automatic network routing (ANR). The complete HPR route is contained in the ANR packet allowing intermediate routing nodes to route the packets with less processing overhead and storage.

HPR also eliminates the error recovery and flow control (session-level pacing) procedures for each link between nodes and moves the error recovery and flow/congestion control procedures to the end-points of an HPR connection. A transport layer using a new error recovery procedure called Rapid Transport

Protocol (RTP) is used by the endpoints of the HPR connection. HPR intermediate nodes have no session or RTP connection awareness. This new transport layer features:

- Selective retransmission error recovery procedure
- Segmentation and reassembly
- Adaptive Rate-Based (ARB) flow and congestion control mechanism that meters data onto a route that allows efficient utilization of network resources while minimizing congestion. ARB uses a preventative rather than reactive approach to flow and congestion control.
- Non-disruptive Path Switch (NDPS) function that automatically reroutes traffic around node or link failures without disrupting end user sessions.
- Detection of Forward Explicit Congestion Notification (FECN) bit set, allowing RTP's adaptive rate-based flow and congestion control algorithm to adjust the data send rate. This algorithm prevents traffic bursts and congestion, maintaining a high level of throughput.

The router implements both ANR routing and Rapid Transport Protocol. Therefore, the router can function both as an intermediate routing HPR node and as an HPR connection endpoint node.

### Interoperability

HPR uses APPN network control functions including class of service (COS)-based least-weight route calculation and transmission priority. HPR interoperates seamlessly with APPN ISR:

- The network automatically adapts to the presence of HPR-capable nodes and HPR-enabled links.
- An APPN network can have any mix of ISR and HPR links, although the greatest benefit of HPR is realized when the network has three or more HPR-enabled nodes with two or more HPR-capable links back-to-back. This allows the middle HPR node to be an HPR intermediate node and use only ANR routing, allowing session data to be routed through the middle node using only NCL.
- A given session route can be made up of a combination of ISR and HPR links.
- HPR uses the same TG and node characteristics for least-weight route calculation as APPN ISR. No special consideration is given to HPR capable nodes or links other than their potentially improved characteristics (such as higher effective capacity if a higher speed link).

### Traffic types

APPN ISR uses the QLLC protocol for X.25 direct data link control, the IEEE 802.2 LLC Type 2 protocol for token-ring, Ethernet, PPP, and frame relay and SDLC protocol for the SDLC data link control. APPN HPR, which is supported on token-ring, Ethernet, PPP, and frame relay, does not use LLC Type 2 protocol, but does use some functions of an APPN link station for XID and inactivity timeout. A single APPN link station is therefore used for ISR or HPR. Different mechanisms are used to distinguish between ISR and HPR traffic depending upon the DLC type:

- For token-ring and Ethernet LAN ports:  
Each protocol that uses a port must have a unique SAP address, with the exception of DLSw (which may use the same SAP address as other protocols because DLSw frames will not be destined for the local MAC address, but rather a DLSw MAC address). A unique SAP address identifies the APPN link station for HPR traffic (Local HPR SAP address parameter). If ISR traffic is destined for a link station, then a different SAP address (Local APPN SAP address

## APPN

parameter) must be used. The ISR traffic uses LLC Type 2 LAN frames. The HPR traffic is handled in similar fashion to LLC Type 1 LAN frames and must have a different SAP address.

The default SAP address for HPR traffic is X'C8'. If X'C8' has already been used by another protocol on a port, the default must be overridden.

**Note:** There is only one APPN link station even though APPN ISR and HPR traffic use different SAP addresses.

- For Frame Relay ports:

APPN ISR traffic and APPN HPR traffic transferred over a frame relay data link connection supports both the RFC 1490 bridged frame format and the RFC 1490 routed frame format.

- RFC 1490 routed frame format

APPN ISR traffic will be transferred over a frame relay data link connection using the connection-oriented multiprotocol encapsulation method defined in RFC 1490 using:

- NLPID = X'08' (Q.933 encoding)
- L2PID = X'4C80' (Layer 2 protocol identifier indicating 802.2 LLC)
- L3PID = X'7083' (Layer 3 protocol identifier indicating SNA-APPN/FID2)

APPN HPR traffic transferred over a frame-relay data link connection does not use IEEE 802.2 LLC. It uses a different multiprotocol encapsulation as defined in RFC 1490 using:

- NLPID = X'08' (Q.933 encoding)
- L2PID = X'5081' (Layer 2 protocol identifier for no Layer 2 protocol)
- L3PID = X'7085' (Layer 3 protocol identifier indicating SNA-APPN/HPR)

APPN HPR does not use a SAP for traffic transferred using the RFC 1490 routed frame format because there is no Layer 2 protocol.

- RFC 1490 Bridged format

APPN HPR uses a SAP for traffic transferred using the RFC 1490 bridged frame format.

- For PPP ports:

- APPN ISR traffic uses 802.2 LLC over the PPP connection.
  - Since there is no layer 2 protocol used in HPR's RFC 1490 encapsulation, no SAP is used for HPR traffic.

- Enterprise Extender Support for HPR over IP

Refer to Table 2 on page 25 for a list of DLCs that support HPR.

**Note:** HPR is not supported over SDLC, X.25, or DLSw ports.

## Dependent LU Requester (DLUR)

The DLUR option extends the support of T2.0 or T2.1 devices containing dependent LUs to APPN nodes. The DLUR function on an APPN network node or an APPN end node works in conjunction with a dependent LU server (DLUS) in a mixed APPN/subarea network. The DLUS function may reside in some other part of the mixed network from the DLUR.

The dependent LU flows (SSCP-PU and SSCP-LU) are encapsulated over an LU 6.2 (CP-SVR) pipe established between the DLUR APPN node and the DLUS SSCP. The CP-SVR pipe is made up of a pair of LU 6.2 sessions using a new CPSVRMGR mode between the DLUR and the DLUS. This pipe brings the SSCP function (in the DLUS) to the DLUR APPN node where it can be made available to attached T2.0/T2.1 nodes containing dependent LUs.

The dependent LU will appear to be located within the domain of the serving SSCP. Session initiation flows will be emulated from the DLUS, but session bind and data paths will be calculated directly between the dependent LU and its session partner. This path may or may not traverse the serving DLUS node.

Set the adjacent node type parameter to **PU 2.0 Node** when defining a link station to a T2.0 adjacent node containing dependent LUs. Set the adjacent node type parameter to **APPN end node** or **LEN end node** when defining a link station to a T2.1 adjacent node containing dependent LUs.

See Table 2 on page 25 for the types of ports providing connection to the downstream PU (DSPU) that are supported.

## Functions Supported

The APPN DLUR option includes the following functions:

- Support for SDLC-attached downstream T2.0 nodes containing dependent LUs that do not support XID exchange.
- Support for downstream T2.0 nodes containing dependent LUs that respond with XID type 0 and XID type 1.
- Support for downstream T2.1 nodes containing dependent LUs that respond with XID type 3.
- Support for dependent LUs that is equivalent to the support provided by the Subarea environment for:
  - Activating PUs and their LUs
  - Locate and be located by other LUs in an APPN or subarea network
  - Determine LU's characteristics
  - Allow terminal operators to logon to applications both in APPN and subarea networks
  - SSCP takeover
  - Uninterrupted LU-LU sessions, if the supporting DLUS (SSCP) fails
  - SLU init, PLU init, and Third-party init

## Restrictions

The DLUR option, as implemented on the router network node, has the following functional restrictions:

- Only secondary LUs (SLUs) can be supported by the DLUR function. An LU supported by DLUR cannot function as a primary LU (PLU). Therefore, the downstream physical unit (DSPU) should be configured as secondary.
- Because only SLUs are supported, Network Routing Facility (NRF) and Network Terminal Option (NTO) are not supported.
- Extended recovery facility (XRF) and XRF/CRYPTO are not supported.

- You must be able to establish an APPN-only or APPN/HPR-only session between DLUS and DLUR. The CPSVRMGR session cannot pass through a subarea network.

### VTAM Considerations for DLUR

The following are example VTAM Switched Major Node definitions for DLUR. You should note that PATH statements are necessary only if VTAM is initiating the connection to the DSPU.

You should refer to *VTAM Resource Definition Reference SC31-6427*, for details of the DLC parameter statements for the Switched Major Node definitions.

```
DABDLURX VBUILD TYPE=SWNET,MAXGRP=400,MAXNO=400,MAXDLUR=20
*****
*IN THE DLCADDR, THE 'SUBFIELD_ID' = CV SUBFIELD OF THE CV91          *
* MINUS 0X90.                                                         *
*FOR EXAMPLE, THE CV94 SUBFIELD IS CODED ON DLCADDR=(4,X,...         *
*****
* Following are PU Statements for 2.0 and for 2.1
*****
* 2.0 PU STATEMENT
*****
*PU20RT  PU  ADDR=05,PUTYPE=2,MAXPATH=8,ANS=CONT,USSTAB=AUSSTAB,
*           ISTATUS=ACTIVE,MAXDATA=521,I_RETRY=YES,MAXOUT=7,
*           PASSLIM=5,IDBLK=017,IDNUM=00035,MODETAB=AMODETAB
*           LOGAPPL=ECH071,DLOGMOD=M23278I
*****
* Path statements are not required if the DSPU is initiating the
* connection to VTAM
*****
*PU20LU1  LU  LOCADDR=2
*PU20LU2  LU  LOCADDR=3
*PU20LU3  LU  LOCADDR=4
*****
* 2.1 PU STATEMENT
*****
*PU21RT  PU  ADDR=06,PUTYPE=2,CPNAME=PU21RT,ANS=CONT,MAXPATH=8,
*           ISTATUS=ACTIVE,USSTAB=AUSSTAB,MODETAB=AMODETAB
*           LOGAPPL=ECH071,DLOGMOD=M23278I
*****
*
* Following are examples of path statement coding for various
* DLC types.
*
* There is no difference in the path statement definitions
* between a PU 2.0 and a PU 2.1
*
* Path statements are required if VTAM is initiating the connection
* to the DSPU.
*****
* Below is SDLC
*****
*A20RT  PATH  PID=1,
*           DLURNAME=GREEN,
*           DLCADDR=(1,C,SDLCNS),
*           DLCADDR=(2,X,5353),
*           DLCADDR=(3,X,C1)
*****
* Below is Frame Relay
*****
*A20RT  PATH  PID=2,
*           DLURNAME=GREEN,
*           DLCADDR=(1,C,FRPVC),
*           DLCADDR=(2,X,4652303033),
*           DLCADDR=(3,X,04),
*           DLCADDR=(4,X,0024)
*****
* Below is Frame Relay BAN
*****
```



```

*A20RT PATH PID=3,
* DLURNAME=GREEN,
* DLCADDR=(1,C,FRPVC),
* DLCADDR=(2,X,4652303033), 2**port name
* DLCADDR=(3,X,04), 3**SAP address
* DLCADDR=(4,X,0024), 4**DLCI
* DLCADDR=(6,X,40000000001) 5**MAC addr
*****
* Below is DLSw
*****
*A20RT PATH PID=3,
* DLURNAME=GOLD,
* DLCADDR=(1,C,TR), 4
* DLCADDR=(2,X,444C53323534), 2**port name
* DLCADDR=(3,X,04), 3**SAP address
* DLCADDR=(4,X,40000000001) 6**MAC address
*
*****
** Below is Token Ring
*****
*PATHT20 PATH PID=1,
* DLURNAME=RED,
* DLCADDR=(1,C,TR),
* DLCADDR=(2,X,5452303030), 2**port name
* DLCADDR=(3,X,04), 3**SAP address
* DLCADDR=(4,X,400000011088) 6**MAC address
*****
** Below is Ethernet
*****
*PATHE20 PATH PID=1,
* DLURNAME=PURPLE,
* DLCADDR=(1,C,ETHERNET),
* DLCADDR=(2,X,454E303030), 2**port name
* DLCADDR=(3,X,20), 3**SAP address
* DLCADDR=(4,X,400000011063) 6**MAC address
*****
* Below is X25 SVC
*****
*A20RT PATH PID=3,
* DLURNAME=GREEN,
* DLCADDR=(1,C,X25SVC),
* DLCADDR=(2,X,583235303033), 2**port name
* DLCADDR=(4,X,C3), 3**Protocol identifier
* DLCADDR=(21,X,000566666), 4**Destination DTE address
*****
* Below is X25 PVC
*****
*A20RT PATH PID=3,
* DLURNAME=GREEN,
* DLCADDR=(1,C,X25PVC),
* DLCADDR=(2,X,583235303033), 2**port name
* DLCADDR=(3,X,0001) 10**Logical channel number
*****
*****
* LU statements
*****
*PU21LU1 LU LOCADDR=2 11
*PU21LU2 LU LOCADDR=3
*PU21LU3 LU LOCADDR=4
*****

```

**Notes:**

- 1 The difference between PU statement coding is:
  - For 2.0 definitions, the PU statement has IDBLK=...,IDNUM=...
  - For 2.1 definitions, the PU statement has CPNAME=...
- 2 Port name in ASCII defined on the router and used by DSPU
- 3 SAP of DSPU (noncanonical, except for Ethernet)
- 3a Station address for SDLC
- 4 DLCI must have 4 digits because it is a half-word
- 5 MAC address of the DSPU (noncanonical) for frame relay BAN

## APPN

- 6 MAC address of the DSPU (noncanonical, except for Ethernet MAC address, which is canonical)
- 7 DLSw appears to VTAM like a token ring DLC
- 8 Protocol identifier
- 9 Destination DTE address (000566666, where:
  - 00 is fixed
  - 05 is the length of the DTE address
  - 66666 is the DTE address)
- 10 Logical channel number. It must have 4 digits because it is a halfword.
- 11 LU coding

See “TN3270E Server” on page 20 for an example of an internal PU path statement.

## APPN Connection Network

When nodes are attached to a shared-access transport facility (SATF), any-to-any connectivity is possible. This any-to-any connectivity allows direct connections between any two nodes, eliminating routing through intermediate network nodes and the corresponding data traversing the SATF multiple times. To achieve this direct connectivity, however, TGs must be defined on each node for all the other possible partners.

Defining connections between all possible pairs of nodes attached to the SATF results in a large number of definitions (increasing on the order of the square of the number of nodes involved) and also a large number of topology database updates (TDUs) flowing in the APPN network. To alleviate these problems, APPN allows nodes to become members of a connection network to represent their attachment to an SATF. Session traffic between two nodes that have been defined as members of a connection network can be routed directly, without passing through a network node (achieves direct connectivity). To become a member of a connection network, an APPN node's port must be "attached" to a Connection Network by defining a connection network interface. When the port is defined, a Connection Network TG is created by the APPN component to identify the direct connection from the port to the SATF (i.e. the connection network). This TG is not a conventional TG as in the case of defined link stations, but rather represents the connection to the Connection Network in the topology database.

**Note:** TGs for end nodes are not contained in the network topology database, but are contained in the node's local topology database. TDUs do not flow through the network when a connection is established through a Connection Network or when an end node is made a member of a Connection Network.

Because the connectivity is represented by a TG from a given node to a Connection Network, normal topology and routing services (TRS) can be used for the network node server to calculate the direct path between any two nodes attached to the SATF (with TGs to the same Connection Network). DLC signaling information is returned from the destination node during the normal locate process to enable the origin node to establish a connection directly to the destination node.

Therefore, to achieve direct connectivity on an SATF, instead of each node on the SATF being defined (or connected) to each other, each node is connected to a

Connection Network. The Connection Network is often visualized as a virtual node on the SATF to which all other nodes are attached. This model is frequently used and, in fact, the term Virtual Routing Node (VRN) is often interchanged with the term Connection Network.

When a connection network is defined, it is named. This name then becomes the CP name of the VRN and must follow all the requirements of any CP name. See Table 22 on page 140 for a list of these requirements.

### Restrictions

- The same connection network (VRN) can be defined on only one LAN. The same VRN can be defined on multiple ports having the same characteristics to the same LAN however.
- There is only one connection network TG from a given port to a given connection network's VRN.
- Because the VRN is not a real node, CP-CP sessions cannot be established with or through a VRN.
- When a connection network is defined on the router network node, a fully qualified name is specified for the *connection network name* parameter. Only connection networks with the same network ID as the router network node may be defined. The network ID of the VRN is then the same as the network ID of the router network node.

## Branch Extender

The Branch Extender (BrNN) function is designed to optimize the connection of a branch office to an APPN WAN backbone network. The BrNN isolates all the end nodes on one or more branch office LANs from the backbone WAN. The domain of a BrNN may contain only end nodes and cascaded BrNNs. The domain of a BrNN does not contain network nodes or nodes with DLUR.

When configuring a BrNN, configure link stations to the backbone to be uplinks. This causes the BrNN to appear as a conventional end node to the backbone. From the perspective of the backbone, all resources in the domain of the BrNN appear to be owned by the BrNN, hiding the topology of the BrNN's domain from the backbone and reducing the number of broadcast locates in the backbone.

A BrNN presents a conventional network node interface over downlinks. End nodes in the domain of the BrNN register their resources with the BrNN and use the BrNN as a conventional network node server.

A BrNN accomplishes:

- Reduction of the number of network nodes in a large APPN network.
- Hidden branch office topology from the WAN.
- Direct, peer-to-peer communication between defined branches connected to the same connection network.
- Reduces CP-CP session traffic on the WAN link.

The following are limitations of Branch Extender:

- Network nodes are allowed to connect only over links that a BrNN defines as uplinks.

## APPN

- Only end nodes or cascaded BrNNs may be attached to a BrNN downlink. Border nodes acting as end nodes and DLUR nodes may not be attached to a BrNN downlink.
- A node cannot connect to a Branch Extender over an uplink and a downlink at the same time.
- A BrNN can have CP-CP sessions with only one network node at a time.

## Extended Border Nodes

Extended Border Nodes (BNs) allow networks with different network IDs to connect to one another. CP-CP sessions will be established across the network boundaries, and directory services flows and session establishment will be allowed to span the interconnected networks. Topology information will not be exchanged across the network boundary. This allows networks with different network IDs to establish CP-CP sessions and provides topology isolation between different networks.

In addition to allowing networks with different network IDs to interconnect, BNs provide a mechanism to subdivide networks with the same network ID into smaller “topology subnetworks”. This subdivision provides topology isolation between the two subnetworks while allowing directory services flows and sessions to span the subnetwork boundaries.

There must be a BN on one side of the subnetwork boundary in order to use this function. When a BN connects to a non-native NN, the BN looks like an EN to the non-native NN, even though the BN is actually a NN.

There may be two BNs, one on each side of the boundary, cooperating to perform this function. When two BNs connect across a subnetwork boundary, the BN will look like a NN to the non-native BN.

A BN will appear to be the NN server for all non-native resources accessible through the BN. This allows the existing APPN directory caching and route calculation functions to work, while enabling the BN to intercept and modify all Locate and BIND flows which cross an inter-subnetwork TG (ISTG).

BNs implement piece-wise optimal session route calculation. Each subnetwork calculates its own part of the session’s route selection control vector (RSCV) to the entry point in the next non-native subnetwork. While the RSCV will be optimal through the native subnetwork, there is no guarantee that the end-to-end session path will be optimal.

### Network Topology Example

Figure 1 on page 15 shows many of the connectivity options provided by the BN function. In general, you can get from any network to any other network except that NetF can only reach network NetE and NetE is the only network that can reach NetF.

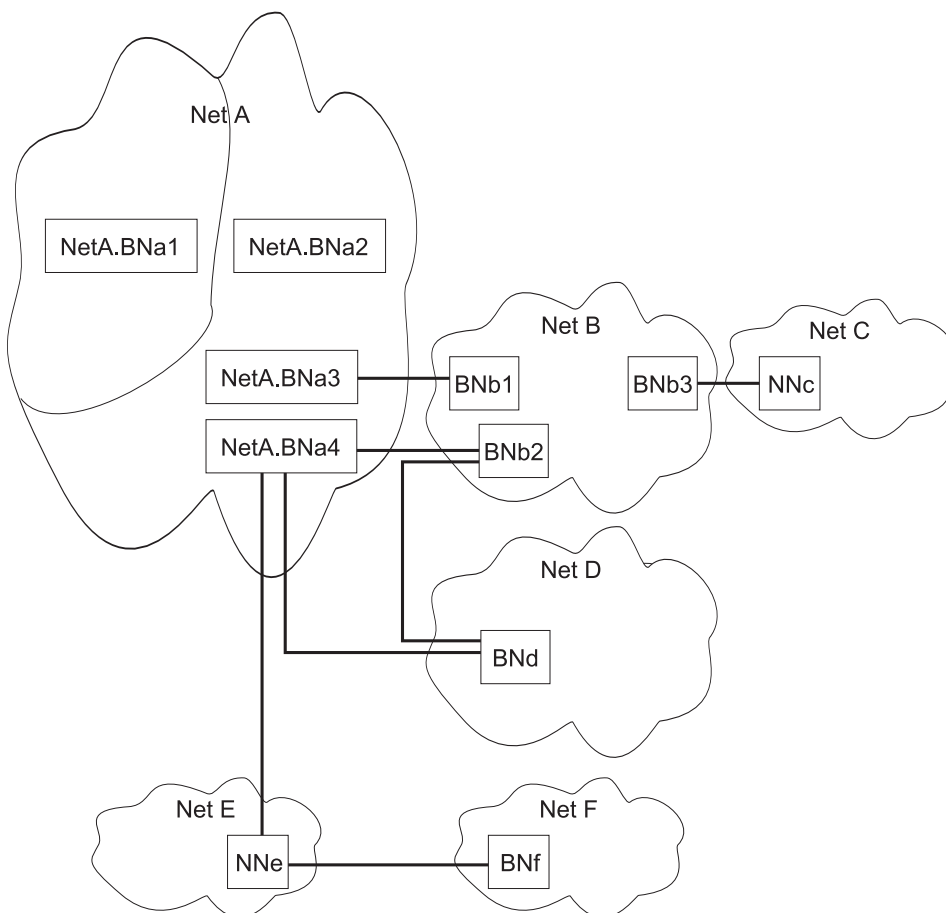

Figure 1. Extended Border Node Connectivity

**Note:** Solid lines represent intersubnetwork TGs.

In this figure:

- Netid subnetwork NetA has been divided into topology subnetworks. The left-most topology subnetwork contains BNa1 which is connected across an intersubnetwork TG to BNa2 in the right topology subnetwork. The netid of both BNa1 and BNa2 is NetA.
- BNa1 is non-native to all the other extended border nodes, including NetA2.
- BNa2, BNa3 and BNa4 are all native to the right topology subnetwork of NETA, and non-native to the other networks, including the subnetwork containing BNa1.
- A BN can interconnect multiple networks as BNa4 connects topology subnetwork of NetA to both NetB and NetD.
- Multiple links can connect two networks as the right topology subnetwork of NetA and NetB are connected by both BNa3/BNb1 and BNa4/BNb2.
- Both ends of an inter-network link must be BNs, unless one of the networks is a peripheral network. In this case, the peripheral network may use a conventional non-BN network node to connect to the BN in the adjoining network. This is shown where peripheral network NetC connects to NetB with NNc.
- Any LU in networks NetA, NetB, NetC, NetD, or NetE can get to any other LU in any of those networks. Both NetC and NetE are connected using conventional non-BN network nodes.

## APPN

- Network NetE is connected using conventional non-BN network node NNe to BNs in NetA2 and NetF. You can not have a network node interconnecting non-peripheral networks, so it is not possible to get from NetF to any network other than NetE.
- You can get from NetA2 to NetE and from NetE to NetA2 since NNe is in a peripheral network. Similarly, you can get from NetF to NetE and from NetE to NetF.

### Session Services Extensions (SSE) for NNS Support

The SSE function of a router is enabled when the router is enabled for APPN. This is true even if the Extended Border Node function is not enabled. This means that the router may act as the network node server for a VTAM end node. As such, it can handle NNS functions for end nodes requesting SLU-initiated sessions, third part initiated sessions, session request queuing, automatic login, session-release requests, and EN TG vector registration.

The SSE function is not used when the router is acting as a Branch Extender since down stream VTAMs are not allowed in that configuration.

### Network Requirements

There are no requirements for other APPN nodes in a network as long as they are not directly connected to a BN across a topology boundary. APPN nodes that are connected to a BN across a topology boundary (across an ISTG) must meet one of these requirements:

- APPN Ver1 with option set 1013, Interoperability with peripheral extended border node
- APPN Ver2, where option set 1013 is part of the base software.

Nodes attached using ISTGs that do not meet either of these requirements will generate alerts and do not handle some of the new flows associated with BNs. However, if other paths through the network are available, you may still have end-to-end connectivity.

## Branch Extender vs. Extended Border Node

Both Branch Extender and Extended Border Nodes serve to minimize network topology. The choice of which to use depends upon the network.

A **branch extender** is the appropriate choice when you have a single network with one or more groups of end nodes where each group of end nodes typically needs to communicate with other end nodes in that group, and only occasionally need to interact with the backbone network.

None of the devices downstream from the branch extender may be network nodes, DLUR, VTAM, or VTAM end nodes.

With the branch extender in place the backbone network's view of the branch extender is as a giant end node with all the downstream LUs being owned by this giant end node. The backbone has no knowledge of the topology downstream from the branch extender, thus reducing the overhead of topology exchanges. Conversely, the branch extender's network node server, which is part of the backbone, will have knowledge of all the LUs owned by the branch extender if the

branch extender is configured to register resources. This serves to reduce the number and size of broadcast searches and topology updates.

An **extended border node** is the appropriate choice when you have multiple networks you want to tie together, or when you have a large network you want to subdivide without restriction on what node types are allowed in the subdivided pieces. There is no concept of upstream or downstream and you can have additional extended border nodes, network nodes, end nodes, DLUR, VTAM, or VTAM end nodes located anywhere in your network. Unlike the branch extender, an extended border node cannot register resources with another network.

## Managing a Network Node

The router network node can act as an APPN entry point that forwards APPN-related alerts to an APPN focal point. APPN focal points may be defined explicitly or implicitly.

You can use SNMP to access these IETF standardized MIBs:

- APPC (RFC 2051)
- APPN (RFC 2155)
- HPR (RFC 2238)
- DLUR (RFC 2232)

You can also use SNMP to access these enterprise-specific MIBs:

- IBM APPN Memory
- IBM Accounting
- IBM HPR NCL
- IBM HPR Route Test
- IBM Branch Extender Node
- IBM Extended Border Node (EBN)

## Entry Point Capabilities for APPN-related Alerts

The router network node can serve as an APPN entry point for alerts related to the APPN protocol. As an entry point, the router is responsible for forwarding APPN and LU 6.2 generic alerts about itself and the resources in its domain to a *focal point* for centralized processing. A focal point is an entry point that provides centralized management and control for other entry points for one or more network management categories.

**Note:** If a focal point is not available to receive an alert from the device, the alert is held (stored) by the device.

Entry points that communicate with a focal point make up that focal point's *sphere of control*. If a focal point explicitly defines the entry points in its sphere of control and initiates communication with those entry points, it is an *explicit focal point*. If a focal point is designated by its entry points, which initiate communication with the focal point, the focal point is an *implicit focal point*. The focal point for the router can be either an explicit or implicit focal point.

Routers configured as branch extender nodes have additional flexibility. As with conventional network nodes, the focal point can directly establish an explicit

## APPN

relationship with the branch extender node. Also as with conventional network nodes, you can configure one or more implicit focal points at the branch extender node.

Unlike conventional network nodes, branch extender nodes can alternatively learn of the focal point from its network node server. When the network node server establishes a relationship with the focal point, either explicitly or implicitly, it will notify all its served end nodes, including served branch extender nodes, of the focal point name.

If the session between the router entry point and its primary focal point fails, the router can initiate a session with a designated backup focal point. Before initiating a session with a backup focal point, the router entry point makes an attempt to reestablish communication with its primary focal point if the router has been assigned session re-establishment responsibility. If that attempt fails, the router switches to the backup focal point.

**Note:** The router will attempt to establish a session with the backup focal point, or will attempt to re-establish the session with the primary focal point, only if the router has an alert to send.

After switching to a backup focal point, the router will periodically attempt to re-establish its session with the primary focal point. The interval between attempts is doubled each time an attempt fails until a maximum interval of one day is reached. From that point on, the attempt is performed daily.

### Notes:

1. If the focal point is explicit and the explicit focal point retains the re-establishment responsibility for itself, this retry mechanism is disabled.
2. If the focal point is explicit and assigns re-establishment responsibility to the router, the router will attempt to reestablish communication until the next restart of APPN in the router.

The router entry point communicates with the focal point through an LU 6.2 session. Multiple-domain support (MDS) is the mechanism that controls the transport of management services requests and data between these nodes. The router network node does *not* support SSCP-PU sessions with focal points.

Management processes within the router's control point are handled by its control point management services (CPMS) component. The CPMS component within the router network node collects unsolicited problem management data from resources within the router's domain and forwards this data to the appropriate focal point.

## Supported Message Units

The router network node uses the following message units for sending and receiving management services data, including alert messages from domain ENs:

### Message unit

#### Description

#### CP-MSU

Control point management services unit. This message unit is generated by CPMS and contains alert information forwarded by the router entry point. CPMS passes CP-MSU message units to MDS.



**MDS-MU**

Multiple-domain support message unit. This message unit is generated by MDS. It encapsulates the CP-MSU for transport between nodes.

## SNMP Capabilities for APPN MIBs

An operator or application at an SNMP network management station can query objects in the APPN MIBs (using the SNMP **get** and **get\_next** commands) to retrieve APPN status information and node statistics. A subset of APPN MIB objects can be modified using the SNMP **set** command. The APPN MIBs can be accessed only using SNMP.

## Topology Database Garbage Collection

Information flows between APPN NNs to inform the NNs about network resources. Each NN keeps a topology database consisting of the names and characteristics of those resources. When a resource is eliminated from the network, it can also be deleted from each NN topology database. When a NN detects that a resource in its topology database is obsolete, the node will broadcast information stating that the resource should be garbage-collected. If NNs receiving this information support Enhanced Garbage Collection, they should delete that resource from their topology database. The record is not actually garbage-collected until the next garbage collection cycle. A NN examines each resource in its topology database once a day.

## Configurable Held Alert Queue

The configurable held alert queue function allows you to configure the size of the held alert queue. If a focal point is not available, the held alert queue saves APPN alerts. When a focal point becomes available, the held alerts are sent. If more alerts arrive than can be held, the oldest alerts are discarded.

**Note:** If you configure a large value for the **Held Alert Queue Size**, the extra memory should be accounted for. You can do this by letting the tuning algorithm automatically calculate the **Maximum Shared Memory** value. See “APPN Node Tuning” on page 39 for additional information about the node tuning algorithm.

## Implicit Focal Point

A focal point is a node with centralized management responsibility. The managing node can contact the managed node (router) and establish a management session. The managing node is then an explicit focal point. When the name of the managing node is configured at the router and the router can initiate a management session, the managing node is an implicit focal point. You can configure a single, primary implicit focal point with up to eight backup implicit focal points, where each focal point is a fully qualified network name. The router will attempt to contact each focal point in order until a successful management session is established.

If the management session is with a backup implicit focal point, the device will periodically attempt to reestablish its session with the primary implicit focal point. The interval between attempts is doubled each time an attempt fails until a maximum interval of one day is reached. From that point on, the attempt is performed daily.

## APPN

**Note:** If an explicit focal point initiates a management session with a device, it will cause a session with an implicit focal point to terminate.

### Dynamic Definition of Dependent (DDD) LUs

The dynamic definition of dependent LUs (DDDLU) is a VTAM facility that allows the logical units to be known by VTAM when they connect to VTAM, rather than during the major node activation of the related PU. With this support, VTAM builds LU definitions from reusable model LU definitions instead of using predefined LUs. The LU definitions are replaced or changed each time the device containing the LU(s) powers on (or notifies that it is enabled and startable).

The DDDLU capability requires some minor changes in VTAM and depends on the activation of the physical unit (PU) being done by a format-1 ACTPU. This format-1 ACTPU can carry the PU Capabilities Control Vector, and should be sent only to devices that send an XID3 with byte 10, bit 3 set to '1' (this PU supports format-1 ACTPU). The PU Capabilities Control Vector will tell whether the sending node supports unsolicited NMVTs (network management vector transport) for Reply Product Set ID (PSID). If unsolicited NMVTs for Reply PSID are supported, DDDLU can be achieved.

The Reply PSID NMVT contains the local address of each LU, a power on/off indicator, the machine type and model number of the device, and optionally other device-dependent information needed to define the logical units. VTAM uses this information to choose an appropriate model LU definition statement to build an LU definition.

### TN3270E Server

The TN3270E Server provides a TN3270 gateway function for TN3270 clients that are downstream of a SNA host running a 3270 application. These clients connect to the server using a TCP connection. This connection is mapped to a SNA dependent LU-LU session that the server maintains with the SNA host. The TN3270E Server handles the conversion between the TN3270 datastream and a SNA 3270 datastream. The TN3270E Server function complies with RFC 1646 and RFC 1647.

**Note:** Use the **load add** command to load the TN3270E software package. Refer to the chapter entitled "Configuring the CONFIG Process" in the *Software User's Guide* for information about the **load add** command.

TN3270 sessions can span APPN networks as well as IP networks using the HPR over IP.

**Note:** The IBM 2212 supports a maximum of 1000 TN3270E sessions.

The TN3270E Server can use a subarea connection or the APPN DLUR function to communicate with the host.

See "Support for Subarea SNA Connections from the TN3270E Server to the Host" on page 24 for more information and see "Configuring TN3270E Using DLUR" on page 71 and "Configuring TN3270E Using a Subarea Connection" on page 73 for sample configurations.

If you are using DLUR to communicate with the host, the local PUs used by the TN3270E Server need to be configured in the host as DLUR internal PUs. The following code is an example of the host VTAM configuration:

```
*
PUJ0E7  PU  ADDR=12,
          IDBLK=077, IDNUM=EEEE7, 077EEEE7
          MAXPATH=8,
          ISTATUS=ACTIVE,
          MODETAB=LMT3270,
          USSTAB=STFTSNA2,
          ANS=CONT,
          MAXDATA=521,
          IRETRY=YES,
          MAXOUT=7,
          DLOGMOD=G22NNE,
          NETID=STFNET,
          PASSLIM=5,
          PUTYPE=2
JCPATH7  PATH  PID=1,
              DLURNAME=VLNN01,
              DLCADDR=(1,C,INTPU),
              DLCADDR=(2,X,077EEEE7)
JC7LU2   LU    LOCADDR=2
JC7LU3   LU    LOCADDR=3
JC7LU4   LU    LOCADDR=4
JC7LU5   LU    LOCADDR=5
JC7LU6   LU    LOCADDR=6
```

**Note:**

077EEEE7 represents the ID block/ID number of the local PU

There are two Telnet servers in the device, the remote console and the TN3270E Server. One IP address will be designated as the TN3270E Server address/port. Telnets to this address/port will be tn3270, and will not get to the remote console. The TN3270E configuration includes the TN3270E config> **set** command to configure the IP address/port for the TN3270E Server.

Only one address can be specified as the TN3270E address.

- Use of an interface address

There can be any number of addresses assigned to an interface. If the system administrator does not want to lose the ability to Telnet to the router using an existing interface address, an additional address (with a subnet mask which RIP and OSPF will advertise) can be added to an interface. We recommend designating an interface address as the TN3270E Server Address.

- Use of the device id

For TN3270 purposes, this address is like an interface address.

- Use of the internal address

This address is advertised over all dynamic routing protocols. It is also continually reachable, whereas interface addresses are only reachable when the interface is up. This address is not recommended as the TN3270E Server Address, except in cases where reachability is guaranteed without respect to the (up or down) state of any interface.

## TN3270 LU Pooling

LU pooling is an enhancement to the TN3270E Server function that makes it easier to configure some TN3270E Server networks. This function allows SNA LUs to be grouped into named "pools". TN3270E clients can then request a connection using

## APPN

the pool's name as an LU name. The TN3270E Server will then choose an LU from the specified pool to service the client's request.

A pool is a logical group of LUs. These LUs can be from different PUs or the same PU, different Host or same Host, etc. When a client specifies a specific pool name, any LU from the pool may be selected.

There is always at least one implicit workstation pool. This pool is referred to as the global default pool. The name of this Pool is defined via the TN3270E config> **set** command. LUs must be added to this pool via the TN3270E config> **add lu** or TN3270E config> **add implicit-pool** command.

### Multiple TN3270E Ports

This enhancement allows users to define multiple TCP ports for the TN3270E Server to "listen" on. This support allows clients to specify the SNA resource they want using a port number.

When the ports are added, the user can define an LU pool to be associated with that port number. Clients that connect to this port and do not specify an LU name will be assigned an LU from this Pool.

TN3270E Server ports can also be defined for a particular type of TN3270 Server (Base or TN3270E) support. Since some base TN3270 clients do not negotiate properly with TN3270E Servers, a port can now be defined for these clients to connect to.

There is always at least one port defined for use by the server. This port is specified via the TN3270E config> **set** command. The Pool associated with this port is always the global default pool.

### TN3270E Server Client IP Address to LU Name Mapping

The TN3270E Server Client IP Address to LU Name Mapping function provides a mechanism for administrators to control client access to the TN3270E Server's resources (ie LUs).

Mapping enhances central administration by allowing the administrator to configure which SNA resources(LUs/Pool) client IP address/subnets will map to and use without modifying client configurations.

Mapping removes the burden on the client of having to connect to a specific port or request a specific LU/Pool on their connect request. These decisions are maintained at the server.

When a client connects in while mapping is enabled, the Server will begin ANDing the client's IP address with the subnet mask of each map definition. The longest match between the incoming Client IP address and the map definition determines which map definition is tried first. If all eligible resources in the map definition are in use, the map definitions are again searched for the next most specific match.

If a map definition contains a full subnet mask (255.255.255.255), indicating that the entry is for a specific client, and a specific LU/Pool is not requested by the client, any LU/Pool in the map definition that matches the connection type may be tried.

If a map definition does not contain a full subnet mask and a specific LU/Pool is not requested, only Pool entries in the map definition will be tried. You must have the subnet map to a Pool. For individual workstation LUs with associated printers, only the workstation LU is required to be in the map definition.

A mixture of Pool and LU types (Workstation or Printer) can be added to a particular map. The resource selected will be based on the type of connection request. The order in which the resources are defined in the map will be the order in which it is chosen for a particular connection request.

## How LUs are Chosen For Client Connections

When IP Address to LU Name Mapping is enabled, client IP Address to LU Name Mappings take priority over everything else. The client's IP address is used to determine which LU/Pool will be used. If the IP Address Map definition specifies *<DEFLT>* as the pool name, the destination port number will be used to determine the SNA resource to use based on the table below. The table will also be used when Mapping is enabled, but no Map definitions exist.

If the client specifies an LU/Pool name on the connect request, that name must match a resource in a Map definition. If the name specified by the client is an LU name that is contained within a Pool, that LU name **MUST** be in the Map definition for the connection to be accepted. It is not sufficient for just an LU's Pool name to be in the Map definition.

When IP Address to LU Name Mapping is not enabled, the following table describes how SNA resources are assigned.

Client Connection	Port Definition	Result
Explicit LU or Pool name specified	Pool name defined	Explicit name is used as long as the incoming name matches the defined name.
Explicit LU or Pool name specified	<i>&lt;DEFLT&gt;</i> defined as Pool name	Explicit name is used as long as the incoming name has been defined
Explicit LU or Pool name specified	No Pool name defined on port	Explicit name is used as long as the incoming name has been defined
No resource name specified	Pool name defined	Name defined on port is used
No resource name specified	<i>&lt;DEFLT&gt;</i> specified as the Pool name	Global default Pool is used
No resource name specified	No resource name specified	Connection request rejected

## TN3270E Server and DDDL

If prompted by VTAM, the TN3270E Server function will use DDDL to create its local LUs in VTAM. Instead of sending all of the Reply PSID's when the ACTPU is received, the server will wait until the LU actually needs to be defined. The LU definition will occur when a TN3270 client connects in and needs an LU that has not been defined to VTAM.

## APPN

# Support for Subarea SNA Connections from the TN3270E Server to the Host

Connecting to a host for establishing an dependent LU-LU session can be accomplished using a traditional subarea connection or using an APPN connection in conjunction with the APPN DLUS/DLUR function. The APPN DLUS/DLUR solution allows the node to appear to VTAM as multiple PU devices, each supporting up to 253 dependent LUs. A node wishing to provide TN3270E Server services over a subarea connection for more than 253 clients simultaneously must also appear as multiple PUs to an attached host.

Subarea connections are supported over the following DLC types:

- Ethernet
- Token Ring
- Frame Relay

**Note:** Support for Subarea SNA connections for TN3270E Server services eliminates the need for APPN in the host. However, APPN must still be configured in the router.

A subarea-attached SNA node configuration with a device performing the TN3270E Server function and appearing to VTAM as multiple downstream PUs is shown in Figure 2.

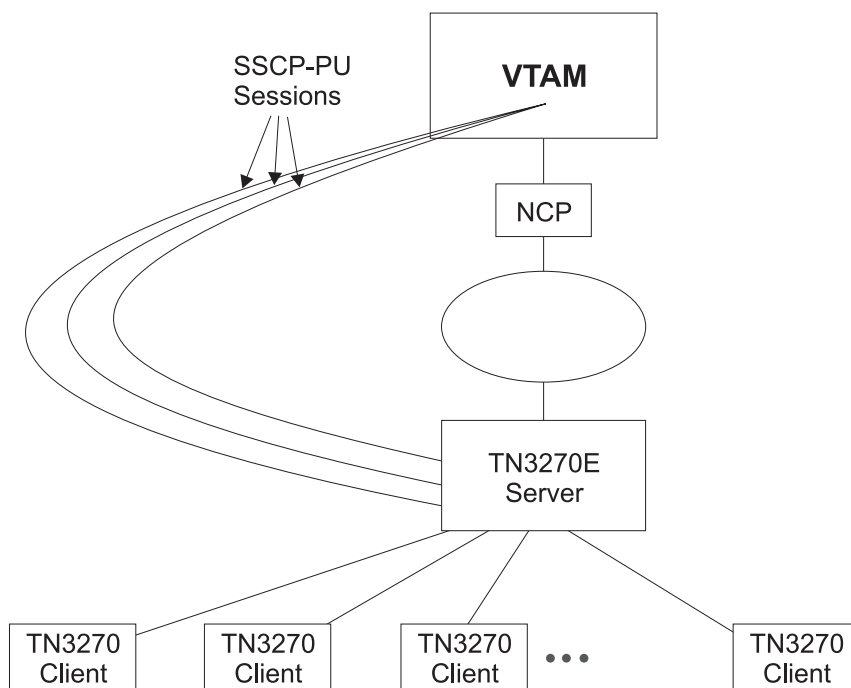

Figure 2. Multiple PUs for Subarea Connected SNA Nodes

See “Configuring TN3270E Using a Subarea Connection” on page 73 for a configuration example.

## Enterprise Extender Support for HPR over IP

Enterprise Extender support for HPR over IP allows HPR/APPN applications to run over an IP backbone network and still take advantage of APPN Class of Service. HPR over IP encapsulates HPR data into a UDP/IP packet for delivery over the IP network.

### Supported DLCs

Table 2 shows the DLC ports supported by the device over APPN:

Table 2. Port Types Supported for APPN Routing

Port Type	Standard	HPR	ISR	DLUR*
Ethernet	Version 2	Yes	Yes	Yes
Ethernet	IEEE 802.3	Yes	Yes	Yes
TR	802.5	Yes	Yes	Yes
Serial PPP		Yes	Yes	No
Serial FR (bridged and routed) **		Yes	Yes	Yes
Frame Relay BAN		Yes	Yes	Yes
Serial LAN bridging		NA	NA	NA
SDLC		No	Yes	Yes
X.25	CCITT X.25	No	Yes	Yes
DLSw (remote only) ***		No	Yes	Yes
APPN/PPP/ISDN		Yes	Yes	No
APPN/FR/ISDN		Yes	Yes	Yes
APPN/PPP/V.25bis		Yes	Yes	No
APPN/PPP/V.34		Yes	Yes	No
HPR over IP		Yes	No	Yes
100Mbps Ethernet		Yes	Yes	Yes
100Mbps TR	802.5	Yes	Yes	Yes

#### Notes:

- \* This column refers to the port providing the connection to the downstream PU (DSPU).
- \*\* Use bridged format when you have two devices connected by frame relay and one of them does not have APPN. Otherwise, use routed format because of improved performance.
- \*\*\* Since APPN runs over DLSw and DLSw runs over X.25, you can route APPN ISR traffic over X.25 by running APPN over DLSw.

### Router Configuration Process

This section describes the router configuration process and includes details about parameters.

## APPN

### Configuration Changes That Require the APPN Function to Restart

- Network ID of the network node
- Control point name of the network node
- XID number (of network node) for subarea connection
- Adjacent node type (of link station)
- Change of node function (EBN, BN, NN)
- Any parameters under the following options:
  - High-Performance Routing (HPR) at the node level
  - Dependent LU Requester (DLUR) at the node level
  - Connection network
  - Class of service
  - Node tuning
  - Node management
  - Focal points
  - Mode name mappings
  - Delete TN3270E parameters
  - Routing lists
  - COS mapping tables

### Configuration Requirements for APPN

APPN routing is configured on the individual adapters supporting the DLC desired. To use APPN routing, at least one of the following DLCs must be configured and enabled:

- LAN ports:
  - Token-ring
  - Ethernet
- Serial ports configured with:
  - PPP
  - Frame relay
  - X.25
  - SDLC
  - Dial circuits over ISDN
  - Dial circuits over V.25bis
  - Dial circuits over V.34
- DLSw
- HPR over IP

The talk 6 code required to configure APPN or TN3270 resides on the corresponding DLL, and that DLL is not loaded unless you have enabled the corresponding function. If you use the Configuration Program to configure the device, this will be taken care of automatically. If you use talk 6 commands to configure the device, you must issue one or both of the following commands and then reboot prior to being able to invoke the talk 6 APPN or TN3270 commands:

- Config> **load add package appn**
- Config> **load add package tn3270**



## Configuring the Router as an APPN Network Node

You can configure the router as an APPN network node in one of three ways, depending on the level of connectivity you desire with other nodes.

- Minimum configuration
- Initiate connections configuration
- Controlling connections configuration

### Minimum Configuration

This group of APPN configuration steps:

- Allows the network node to accept any request it receives from another node to establish a connection.
- Restricts the network node from initiating connections with other nodes.

If you choose the minimum configuration steps, adjacent nodes must define connections to the router network node to ensure connectivity. Because APPN nodes can initiate CP-CP sessions with the router network node, these nodes do not need to be defined in the router's configuration. In general, when configuring APPN on the router, you can simplify the task considerably by allowing the router network node to accept connection requests from any node. Configuring the network node in this manner eliminates the need to define information about adjacent nodes, except in the following cases:

- The adjacent node is a LEN end node. LEN end nodes do not support CP-CP sessions, so information about such nodes and their LU resources must be configured on the router network node.
- You want the router network node to be able to initiate a CP-CP session with an adjacent APPN node.

In these cases, you must specify information about the adjacent node when enabling APPN routing on the specific port you are using to connect to the adjacent node, and should follow the configuration steps described in "Initiate Connections Configuration" on page 28.

Use the following procedure for minimum configuration steps:

1. If you are configuring APPN using a DLSw port:
  - a. Enable bridging on the node
  - b. Enable DLSw on the node
  - c. Define the DLSw port with a locally administered MAC address for DLSw.
2. Enable APPN routing on the port.

**Note:** Since *Service Any* is enabled by default, the node accepts any request for a connection that it receives from another node.

3. Enable the APPN Network Node.
4. Configure the following parameters:
  - Network ID
  - Control point name
5. Define the XID number for subarea connections parameter for the APPN network node (optional).
6. Accept all other defaults.
7. Optionally do the following:

## APPN

- Modify High-Performance Routing parameters
- Configure Dependent LU Requester
- Define connection networks
- Define new COS names or mode name mappings
- Tune the performance of this node
- Perform node service trace diagnostics
- Collect statistics for this network node

### Notes:

1. APPN routing must be defined and enabled on the specific ports you configure the router network node to use.
2. Bridging and DLSw must still be enabled on the specific adapter ports you desire the device network node to use.

### Initiate Connections Configuration

This group of APPN configuration steps:

- Allows the network node to accept any request it receives from another node to establish a connection.
- Enables the network node to initiate connections with other nodes that you specify, including LEN end nodes.

Because APPN nodes can initiate CP-CP sessions with the router network node, these nodes do not need to be defined in the router's configuration, except in the following cases:

- The adjacent node is a LEN end node. LEN end nodes do not support CP-CP sessions, so information about such nodes and their LU resources must be configured on the router network node.
- You want the router network node to be able to initiate a CP-CP session with an adjacent APPN node.

If neither of these cases apply to your configuration, you should follow the configuration steps described in "Minimum Configuration" on page 27.

Use the following procedure for initiate connections configuration :

1. If you are configuring APPN using a DLSw port:
  - a. Enable bridging on the node
  - b. Enable DLSw on the node
  - c. Define the DLSw port with a locally administered MAC address for DLSw.
2. Select the ports over which to initiate connections to adjacent nodes. The following are the DLC port types supported by APPN:
  - Token-ring LAN port
  - Ethernet LAN port
  - Frame-relay serial port
  - PPP serial port
  - X.25
  - SDLC
  - DLSw
  - IP port

3. Enable APPN routing on APPN ports with the *enable APPN routing on this port* parameter.

**Note:** Since *Service Any* is enabled by default, the node accepts any request for a connection that it receives from another node.

4. Define APPN link stations on the selected DLC ports for the adjacent nodes to which this network node may initiate a connection.

**Note:** Link stations do not have to be defined on every port, only those over which you want to initiate connections to adjacent nodes.

5. Enable the APPN network node.
6. Configure the following parameters for the APPN network node:
  - Network ID
  - Control point name
7. Define the XID number for subarea connections parameter for the APPN network node (optional).
8. Accept all other defaults
9. Optionally do the following:
  - Modify High-Performance Routing parameters
  - Configure Dependent LU Requester
  - Define connection networks
  - Define new COS names or mode name mappings
  - Tune the performance of this node
  - Perform node service trace diagnostics
  - Collect statistics for this network node

## Controlling Connections Configuration

This group of APPN configuration steps:

- Allows the network node to accept requests only from nodes that you specify.
- Enables the network node to initiate connections with other nodes that you specify, including LEN end nodes.

This configuration provides a higher level of security because you explicitly define which APPN nodes may communicate with this router network node. A connection request from an adjacent node will be accepted only if its fully qualified CP name parameter has been configured on this network node. This group of configuration steps optionally enables you to have a secure link with each adjacent node by configuring the session level security feature for each link.

Use the following procedure for the controlling connections configuration:

1. Select ports over which you desire to establish connections to adjacent nodes from the following DLC port types supported by APPN:
  - Token-ring LAN port
  - Ethernet LAN port
  - Frame-relay serial port
  - PPP serial port
  - X.25
  - DLSw
  - SDLC

## APPN

- IP port
2. Define ports selected as direct APPN ports with the following parameters:
    - Enable *APPN routing* on this port
    - Disable the *service any port* parameter
  3. If you are configuring APPN using a DLSw port:
    - Enable bridging on the node
    - Enable DLSw on the node.
    - Define the DLSw ports with the following parameter:
      - Define a locally administered MAC address for DLSw
      - Disable the *Service any* node parameter
  4. Enable APPN routing on the port.
  5. Define APPN link stations on the selected DLC ports for the adjacent nodes:
    - that may initiate a connection to this network node.
    - which you desire this router network node to initiate a connection.

Specify the following link station parameters:

    - Fully Qualified CP name of adjacent node (required)
    - Any required addressing parameters for adjacent node
    - And optionally:
      - CP-CP Session Level Security
      - Security Encryption Key
  6. Enable the APPN network node.
  7. Configure the following parameters for the APPN network node:
    - Network ID
    - Control point name
  8. Define the XID number for subarea connections parameter for the APPN network node (optional):
  9. Accept all other defaults.
  10. (Optional) Configure the following router network node options:
    - Modify High-Performance Routing parameters
    - Configure Dependent LU Requester
    - Define connection networks
    - Define new COS names or mode name mappings
    - Tune the performance of this node
    - Perform node service trace diagnostics
    - Collect statistics for this network node

## Configuring Branch Extender

To configure Branch Extender, set the following configuration parameters as appropriate for your network.

1. Use the **set node** command to:
  - a. Answer 1 for Branch Extender to the *Enable Branch Extender or Border Node* question. If you answer 0, none of the following Branch Extender questions will appear.

- b. Answer yes or no to the *Permit search for unregistered LUs* question depending on whether or not you want to allow searches from the backbone for LUs that were not registered with the network node server.
  - c. Your answer to the *Branch uplink* question will determine the default for the analogous link level question.
2. Use the **add link** command to:
- a. Answer yes to the *Branch uplink* question if you want the router to appear as an end node on this link. An end node is for links to network nodes in the backbone. Note that this question doesn't appear and is forced to yes if you have defined the adjacent link station to be a network node on one of the earlier configuration prompts. Answer no if you want the router to appear as a network node on this link. A network node is for links to end nodes
  - b. The *Is uplink to another Branch Extender node* question is asked only if this link has been defined as a limited resource and has also been defined as a Branch Extender uplink. Answer yes if the adjacent node is another Branch Extender.
  - c. The *Preferred network node server* question is asked only if the adjacent node is a network node and CP-CP sessions are supported on this link. Since you can only have a single preferred network node server you won't be prompted for this question once it has been set to yes on any link.

## Configuring Extended Border Nodes

To configure extended border node you must configure one or more of these parameters:

- Set node
- Add port
- Add link
- Add routing\_list
- Add cos\_mapping\_table

### Set node

The previously existing prompt used to enable branch extender has been expanded to allow you to choose the branch extender function, the extended border node function, or neither. Only if you enable the extended border node function will any of the other extended border node prompts appear.

*Subnetwork visit count* is the first prompt. This parameter defines the maximum number of topology subnetworks a session may span. The value defined here is used as the default value for the extended border node. You can specify different values for the *subnetwork visit count* when adding ports, links, or routing lists.

*Cache search time* is the next node level prompt. This specifies the number of minutes the extended border node will retain information on multi-subnetwork searches. The intention is for this to be the primary mechanism for limiting the size of this cache. However, the next parameter can also be used to control the size of this cache.

*Maximum search cache size* is next. This controls the same data structure controlled by the previous parameter. If set to zero, the maximum size is unlimited. Entries will be discarded only after the search cache time has expired. If you prefer

## APPN

to have a fixed maximum size for the search cache then specify that here. If this maximum is reached before any entries exceed the time limit the least recently entries are discarded.

*List dynamics* is the next prompt, and it allows you to control how the extended border node determines possible next hops when attempting to locate resources (LUs). The temporary list of possible next hop CPs is built dynamically by the operational code whenever the border node is attempting to locate a resource. This parameter specifies source(s) of next hop CP name(s) the extended border node may use to build this temporary dynamic list of CP names.

After the temporary list is built, it is always ordered so that configured next-hop CPs are first followed by CPs associated with similarly named known resources. Additional reordering may be performed. Once all the reordering is complete, the extended border node starts searching for the target resource one CP after another.

Note that once the extended border node actually locates a resource it will remember the next hop CP and always use that next hop CP for that particular resource, ignoring the routing lists. Entries from this table of located resources can be quite long lived. They are discarded if the table reaches its maximum size, a later search to that CP fails to locate the resource, or if search from that LU comes from a different CP.

The list dynamics parameter is set to one of the following values. It is possible to respecify this value for individual routing lists when, and if, you configure individual routing lists.

**None** The LU name of the destination resource is compared to the LU name(s) configured in the routing list(s). The routing list with the best LU name match is selected, and the next hop CP name(s) from that configured list are placed in the dynamically built list. This is the only source of possible next hop CP names when list dynamics is set to none.

Note that if an LU name does not appear in a routing list the LU will not be reachable by the extended border node when this list dynamics parameter is set to none.

### Limited

This augments the list of next hop CP names obtained from the best match configured routing list with CP names obtained from the extended border node's knowledge of existing resources and topology. These additional CP names are obtained by:

- Adding all native extended border nodes
- Adding all non-native, adjacent extended border nodes and network nodes with NETIDs that match the NETID of the destination resource.
- Examining the table of resources already known to the extended border node due to the receipt of a find or found GDS variable. These resources are cached in the Directory Services database. For any entries where the Netid of the cached LU is the same as the destination of the current search, add the NNs of the cached LU to the list of next-hop CPs.

None of these dynamically obtained next-hop CP names are permanently saved with the configuration data. The list is recreated whenever a resource needs to be located.

**Full** This functions the same as *limited*, except the restriction on matching NETIDs is removed when adding all non-native, adjacent extended border nodes and network nodes.

If *List optimization* is enabled, the reordering process described in 32 is repeated a second time and the CP names obtained from configured data are also eligible to be reordered.

## Add port

If extended border node is enabled, two additional prompts are presented when you invoke the add port menu item. Both of these new items establish the default for analogous parameters at the link level. The values of these parameters at the link level determine link station behavior.

*Subnetwork visit count* is the first of these, and describes the same concept as defined at the node level. When a port is first configured this parameter is initialized to the node setting. With this parameter you allow individual ports to deviate from the node level setting.

*Adjacent subnetwork affiliation* is controlled by the other new extended border node prompt. This allows you to define whether or not the adjacent node is in the same network as the extended border node. The value specified here will be used as the default value for all links through the port. Allowed values are:

**Native** Adjacent node is in the same topology subnetwork as the extended border node.

### Non-native

Adjacent node is not part of the extended border node's topology subnetwork.

### Negotiable

Adjacent node may or may not be in the same topology subnetwork depending upon how the adjacent node is defined. The adjacent node is in the extended border node's topology subnetwork unless the adjacent node's corresponding link definition is one of:

- Non-native
- Negotiable and the adjacent node has a different network name
- Negotiable and the adjacent node has defined the link as non-native

## Add link

If extended border node is enabled the same two additional prompts are presented when you invoke the add link menu item as were previously presented under add port.

*Subnetwork visit count* and *adjacent subnetwork affiliation* are the same concept as defined at the port level. They are initialized to the corresponding port setting when a link is first configured. You change the value here if you want different links to have different values even though they are on the same port.

## Add Routing List(s)

A configured routing list allows you to explicitly define one or more possible next hop CPs for one or more destination resources (LUs). A wildcard character "\*" may be used when defining the LU names to reduce the amount of configured data. You can also vary some of the node level defaults for a given routing list.

## APPN

You can define multiple routing lists. Typically a group of LUs with similar routing requirements would be configured into a single routing list. Additional groups of LUs, each group with its own routing requirements, would be configured into additional routing lists.

There are limits on the number of LU names and number of CP names used in routing lists. These limits vary according to the model router you have. See Table 34 on page 169 for the configuration command detail. Limits have been set to allow as much flexibility as possible in various environments. The ability of the router to handle the specification of many routing lists, each with many LU names and CP names, is limited by the availability of configuration nonvolatile memory, router memory, and APPN shared memory. See “APPN Node Tuning” on page 39 for a discussion of the APPN tuning parameters which control the amount of shared memory.

Recall from the discussion under the set node prompt that configured routing lists are never modified by operational code. When the extended border node uses a given routing list it copies the next hop CP names into a temporary routing list. This temporary dynamic routing list is augmented with dynamic entries as allowed by your configuration setting of the list dynamics parameter. This temporary list is short lived, and is discarded once the destination resource is found or the list is exhausted.

The *routing list name* is the first prompt you see when adding or modifying a routing list. This name is not used by the operational code at all. It's purpose is to allow you to identify a specific routing list if you want to modify it or delete it at some later time.

*Subnetwork visit count* and *list optimization* are the next two prompts, and follow the same concept as the analogous parameters defined at the node level. A new routing list initializes these values with the current node level settings. You change these values for individual routing lists as your requirements dictate.

*Destination LU* prompt(s) are next. Here you may configure at least one, and optionally more, destination resources. Any of the FQLU names may be prematurely terminated with a trailing wildcard “\*” to identify a group of LUs. You may not imbed a “\*” in the middle of an FQLU name.

One of your routing lists may specify a standalone “\*” as one of the destination LUs. If this is done then that routing list is known as the *default routing list*, and this default routing list will be used by the extended border node for all destination LUs that don't better match the LUs specified in the other routing lists. This list is also used to find LUs when INAUTHENTIC NETID is indicated.

When modifying an existing routing list with many LU names the process of stepping through the LU names could be quite tedious. There are a number of shortcut keys defined to help speed stepping through an existing list of names. Those shortcut keys are defined in the section with the configuration command detail.

*Routing CP* prompt(s) are the last part of entering a routing list. Here you supply the names of one or more CPs that may know how to reach the configured list of LUs. Along with each CP name you may configure an optional subnetwork visit count. This allows you to specify a different maximum number of subnetworks a session may traverse for different CPs.



In addition to explicitly configuring FQCP names there are a couple keywords defined that equate to the local node's CP name, all native extended border nodes, etc. See the section with configuration command detail for those keywords.

As with the LU name list, the same shortcut keys are available to speed stepping through an existing CP name list.

## Add COS Mapping Table

The class of service mapping table allows for the conversion of non-native COS names to native COS names and vice versa. Non-native networks using the same COS names as the extended border node's native network need not have a COS mapping table defined. If only some of the non-native COS names differ from the native COS names, then only those that differ should be configured in a COS mapping table.

A given COS mapping table may apply to a single or multiple non-native networks. You may configure multiple COS mapping tables as necessary.

There are limits on the number of non-native network names used in COS mapping tables. These limits vary according to the model router you have. See Table 35 on page 172 for the configuration command detail. Limits have been set to allow as much flexibility as possible in various environments. The ability of the router to handle the specification of many COS mapping tables, each with many non-native network names and COS name pairs, is limited by the availability of configuration nonvolatile memory, router memory, and APPN shared memory. See "APPN Node Tuning" on page 39 for a discussion of the APPN tuning parameters which control the amount of APPN shared memory.

*COS mapping table name* is the first prompt. As with the analogous name for routing lists, this parameter is not used by the operational code. It's purpose is to allow you to refer to a specific COS mapping table so that you can modify or delete it. Different COS mapping tables must have different names, but a given COS mapping table may have an identical name as a routing list.

*Non-native CP name(s)* are prompted for next. These are used to specify the non-native network(s) that this COS mapping table applies to.

As with LU names in a routing list, you may prematurely terminate any of the FQCP names at any point with a trailing wildcard "\*". This allows you to specify a range of non-native FQCP names in one or more non-native networks. You may not imbed a wildcard in the middle of a FQCP name.

One COS mapping table in the extended border node may have a standalone wildcard "\*" as one of the non-native CP names. Such a table is known as the *default COS mapping table*, and will be the table used by the extended border node whenever no other table has a CP name that matches the non-native network.

*COS name pairs* are the final part of configuring a COS mapping table. Here you are prompted for one or more pairs of COS names. Each COS name pair consists of a native COS name followed by the corresponding COS name used in the non-native network.

The extended border node uses this table to translate from native to non-native networks and vice versa. If you need to map multiple native COS names into a common non-native COS name you should configure one COS name pair for each

## APPN

possible mapping. Similarly you may need to map multiple non-native COS names into a common native COS name, and that too can be accomplished by configuring a COS name pair for each possible mapping. If there are multiple possible mappings in a table the extended border node will use the first exact mapping found.

Each COS mapping table may have one COS name pair where the non-native COS name is a wildcard “\*” . This is the *default COS mapping* entry for that table, and it is used to translate all unrecognized non-native COS names into a single native COS name. Each COS mapping table may have one of these default COS mapping entries. You can never code a “\*” as the native COS name.

## High-Performance Routing

See Table 2 on page 25 for a list of ports that support HPR.

See “Configuration Requirements for APPN” on page 26 for information about configuring the protocols that support APPN and HPR routing over direct DLCs on the router. In the case of HPR parameters such as retry and path switch timers, the configuration is done at the node level and is not specified on individual adapters.

## DLUR

See Table 2 on page 25 for a list of ports that support DLUR.

## Configuring Focal Points

Focal points can be explicit or implicit. Explicit focal points are configured at the focal point itself. No configuration at the router is required.

Implicit focal points on the other hand are configured at the router. You configure them with the command **add focal\_point**. Add the primary implicit focal point first. If you add another focal point, it is known as the first backup implicit focal point. If you add yet another, it is known as the second backup implicit focal point. Up to eight backup implicit focal points may be added for a total of 9.

To delete a focal point use the command **delete focal\_point**. You will be prompted for the name of the focal point to delete. When the name is deleted, the remaining focal points retain their relative position with each other. Subsequent focal points will be added at the end of the list.

There is no way to insert a focal point in the middle of the list. You must delete them one at a time and then re-enter the entire list.

## Configuring Held Alert Queue Size

To configure the size of the held alert queue enter the command **set management** and answer the **Held Alert Queue Size** question. The queue defaults to a size of 10 alerts, and valid values are from 0 through 255 alerts.

As you increase the size of the held alert queue, additional memory is needed. If you set it to a high value, you may want to adjust the “Maximum Shared Memory” value. See “APPN Node Tuning” on page 39 for additional information.

## Defining Transmission Group (TG) Characteristics

When you configure APPN on the router, you can specify the Transmission Group (TG) characteristics for the link station that defines a connection between the router network node and an adjacent node. These characteristics, such as the security of a link or its effective capacity, are used by APPN when calculating an optimum or least-weight route between nodes in the APPN network.

APPN on the router uses a set of default TG characteristics for each port (or DLSw port). These defaults, defined by the *default TG characteristics* parameter apply to all the TGs for link stations defined on a port unless they are overridden for a particular link station by the *modify TG characteristics* parameter.

These default TG characteristics are also used for dynamic link stations established when an adjacent node requests a connection with the router network node, but does not have a predefined link station definition on the router network node. The *Service any node* parameter must be enabled.

You can change the following parameters using the router **talk 6>** interface as well as the Configuration Program:

- time cost
- byte cost
- user-defined TG characteristics 1 - 3
- effective capacity
- propagation delay
- security

## Calculating APPN Routes Using TG Characteristics

The APPN route calculation function uses a COS definition for TGs which is a table containing rows of TG characteristic ranges. Each row defines a given range for each of the eight TG characteristics and the corresponding TG weight for that row. APPN starts at the top of the table and continues down the table until all eight of the TG characteristic parameter values fit within the ranges given for that row. APPN then assigns the weight of that row as the TG weight for that link. There is also a COS definition for nodes that calculates a node's weight. The route calculation function continues until it has found the path with the least combined weight of TGs and nodes. This is the least weight route.

As an example of how TG characteristics are used to influence the selection of a route through an APPN network node, suppose that a route from network node router A to network node router D can pass through either network node router B or router C. In this example, router A defines serial port PPP connections to both router B and router C. However, the connection from router A to router B is a 64-Kbps link, while the connection from router A to router C is a slower-speed 19.2-Kbps link.

To ensure that the higher-speed connection from router A to router B is viewed as the more desirable path for routing APPN interactive traffic, the effective capacity TG characteristic for the link station associated with this path would be modified. In this case, the default value for effective capacity is X'38', which correctly represents a link speed of approximately 19.2-Kbps. However, the effective capacity would be changed to X'45' to properly represent the 64-Kbps link. Since the effective capacity for the TG from router A to router B is now X'45', this path is assigned a lower

## APPN

weight in the COS file for interactive traffic. Consequently, the connection from router A to router B is represented as more desirable than the connection from router A to router C.

You can also change the TG characteristics if you purposefully want to favor certain TGs for route selection. In addition to the five architected TG characteristics, there are also three user-defined TG characteristics. You may define these user-defined TG characteristics in order to bias the route selection calculation in favor of certain paths.

**Note:** For DLSw ports the TG characteristics that you define effect only the selection of routes between APPN nodes over these DLSw ports. These characteristics have no direct effect on any intermediate routing performed by DLSw on APPN's behalf.

## COS Options

You can use a template to create new user-defined COS names and associated definitions for TGs and nodes which can be used with new mode names or mapped to existing mode names.

In addition you can create new mode names that can be mapped to existing COS names.

Each COS definition file is identified by a COS name and contains an associated transmission priority and a table of ranges of acceptable TG and node characteristics that APPN compares against actual TG and node characteristics to determine weights for TGs and nodes from which APPN calculates the least weight route for the session. Using the Configuration Program you can:

- View a COS definition file:
  - View the transmission priority
  - View a list of node row references along with their corresponding weights
  - View a list of TG row references along with their corresponding weights
- Select standard COS tables as templates to define a new user-defined COS definition file with a new COS name:
  - Import an IBM-defined COS definition file to use as a template
  - Import a previously exported user-defined COS definition file to use as a template
- Define the minimum and maximum ranges for the user-defined TG characteristics within an IBM-defined COS definition.

**Note:** In an IBM-defined COS definition you can edit only the user-defined TG characteristic ranges.

Using Configuration Program or **talk 6** you can:

- Use standard COS tables .
- Define a new mode name and its mapping to a COS name.
- Change a mode name to COS name mapping:
  - Re-map an IBM-defined mode name to a different COS name.
  - Re-map a previously specified user-defined mode name to a different COS name.

Refer to the discussion of Topology and Routing Services in the *SNA APPN Architecture Reference*, SC30–3422, for a description of standard COS tables.

## APPN Node Tuning

The performance of the router APPN network node can be tuned in two ways:

- By manually setting the values of the *maximum shared memory*, *percent of APPN shared memory to be used for buffers*, and the *maximum cached directory entries* tuning parameters using the **talk 6** option of the command line interface.
- By selecting values for the *maximum number of ISR sessions*, *maximum number of adjacent nodes* and other parameters shown in Table 8 on page 94, and having the tuning algorithm automatically calculate the *maximum shared memory* and *maximum cached directory entries* tuning parameter values.

Use the Configuration Program to invoke the tuning algorithm.

The *maximum shared memory* parameter affects the amount of storage available to the APPN network node for network operations. For example, you can allow APPN to have a 4K RU size by setting *maximum shared memory* to at least 1 Megabyte and setting *percent of APPN shared memory used for buffers* to a sufficiently large value to allow at least 1 Megabyte of memory to be available to the buffer manager.

The *maximum cached directory entries* parameter affects the amount of directory information that will be stored or cached to reduce the time it takes to locate a resource in the network.

In general, tuning the APPN network node involves a trade-off between node performance and storage usage. The better the performance, the more storage required.

### Tuning Notes

1. The tuning parameter settings should reflect anticipated growth in your network.
2. If you define connection networks within your APPN network and you anticipate that most end nodes will initiate LU-LU sessions with other end nodes on the same connection network, you should set the *maximum number ISR sessions* parameter to a smaller value (1). Using connection networks in this manner reduces the shared memory requirements for the router network node because most LU-LU sessions will not flow through the APPN component in the router.
3. Because the *maximum shared memory* parameter affects storage allocation within the router, you should use care when explicitly defining this parameter. Use the defaults as a guide when increasing or reducing maximum shared memory manually.

## Node Service (Traces)

The APPN Node Service (Traces) option allows you to start any APPN trace through **talk 6** or the Configuration Program. The traces are activated when the configuration file is applied to the router. The traces will continue to be active until they are stopped when a new configuration that stops the traces is applied to the router.

**Note:** Running traces on the router can affect its performance. Traces should be started only when needed for node service and should be stopped as soon as the required amount of trace information is gathered.

## APPN

The APPN traces are grouped into the following 5 categories:

- Node-level traces specify traces concerning the overall APPN network node.
- Inter-process signals traces specify component-level traces concerning signals between APPN components.
- Module entry and exit traces specify component-level traces concerning the entry and exit of APPN modules.
- General traces specify component-level traces concerning the APPN components.
- Miscellaneous traces specify trace information about DLC transmissions and receptions.

## APPN Trace Enhancements

The following are enhancements to the APPN traces:

- You can now enable/disable all trace flags through `talk 6` using the *Turn all trace flags off* question asked under the **set trace** command or by using the Configuration Program. See 118 for more information.
- You can now filter the data link control transmissions and receptions trace data by message type and/or by specifying the maximum length of data per packet to trace. See Table 14 on page 116 for information.

## Accounting and Node Statistics

Intermediate sessions are LU-LU sessions that pass through the APPN network node, but whose endpoints (origin and destination) lie outside of the network node. Information about intermediate sessions is generated by the ISR component in the network node and falls into two categories:

- Intermediate session names and counters
- Route selection control vector (RSCV) data for intermediate sessions

Enabling the *collect intermediate session information* parameter instructs the router to collect session names and counters for all active intermediate sessions. Enabling the *save RSCV information for intermediate sessions* parameter instructs the router to collect RSCV data for active intermediate sessions. The RSCV data is useful for monitoring session routes. In both cases, you can retrieve the data on active sessions by issuing SNMP **get** and **get-next** commands for variables in the APPN Management Information Base (MIB).

The *collect intermediate session information* function defaults to being disabled. You can enable it using the Configuration Program or using the **set management talk 6** command. Once enabled, you can control it, including disabling and re-enabling, using SNMP **set** commands to the APPN accounting MIB.

**Note:** This function can use a significant amount of APPN memory. You should configure APPN with the needed memory before you enable the collection of ISR information.

For accounting purposes, you can maintain records of intermediate sessions passing through the network node. The data records can be created and stored in router memory. SNMP must be used to retrieve data from accounting records stored in the router's local memory.

**Notes:**

1. You can enable collection of active intermediate session data (session counters and session characteristics) in SNMP MIB variables explicitly or implicitly.  
To enable collection explicitly, set the *collect intermediate session information* parameter to yes.  
To enable collection implicitly, set *create intermediate session records* to yes. This setting will override the setting of *collect intermediate session information*.
2. Configuration changes to the APPN accounting parameters made using the **talk 6** interface will not take effect until the router or the APPN function on the router is restarted. You can make changes interactively, however, by issuing SNMP **set** commands to modify the APPN MIB variables associated with the configuration parameters. Refer to the *Software User's Guide* for a list of these MIB variables.
3. Data on intermediate session RSCVs is obtained by examining the BIND request used to activate a session between two LUs. RSCV data is not collected for sessions that have already been established because the BIND information for those sessions is not available.
4. Intermediate session data is not collected for HPR sessions since intermediate sessions are not part of HPR. If the router contains an ISR/HPR boundary, intermediate session data is collected when it flows across that boundary.

## DLUR Retry Algorithm

If communication between DLUR and DLUS is broken, the following algorithm is used to reestablish communication:

If *Perform retries to restore disrupted pipe* is No:

- If DLUR receives a non-disruptive UNBIND (sense code of X'08A0 000A'), DLUR waits indefinitely for a DLUS to reestablish the broken pipe.
- If the pipe fails for any other reason than a non-disruptive UNBIND, DLUR attempts to reach the primary DLUS once. If this is unsuccessful, DLUR attempts to reach the backup DLUS. If DLUR is unable to reach the backup DLUS, it waits indefinitely for a DLUS to reestablish the broken pipe.

If *Perform retries to restore disrupted pipe* is Yes, DLUR will attempt to reestablish the pipe based on the following configuration parameters:

- Delay before initiating retries
- Perform short retries to restore disrupted pipe
- Short retry timer
- Short retry count
- Perform long retries to restore disrupted pipe
- Long retry timer

There are two cases that determine the retry algorithm:

- For the case of receiving a non-disruptive UNBIND:
  1. Wait for the amount of time specified by the *Delay before initiating retries* parameter. This delay allows time for an SSCP takeover, where the pipe would be reestablished by a new DLUS without action on the DLUR's part.
  2. Attempt to reach the primary DLUS.
  3. If unsuccessful, attempt to reach the backup DLUS.
  4. If the attempt to reach the backup DLUS is unsuccessful, DLUR will retry as described in steps 5 - 7 as long as the DSPU is requesting ACTPU.

## APPN

5. Wait for the amount of time specified by the *Long retry timer*.

**Note:** If *Perform long retries to restore disrupted pipe* is No, no further retries will be attempted.

6. Attempt to reach the primary DLUS.
7. If the attempt to reach the primary DLUS is unsuccessful, attempt to reach the backup DLUS.

### Example:

- Assume the following parameter values:
  - *Delay before initiating retries* = 120 sec
  - *Perform short retries to restore disrupted pipe* = yes
  - *Short retry timer* = 60 sec
  - *Short retry count* = 2
  - *Perform long retries to restore disrupted pipe* = yes
  - *Long retry timer* = 300 sec
- Pipe activation fails.
- Wait 120 seconds (the value of *Delay before initiating retries*).
- Retry the primary DLUS and, if this fails, retry the backup DLUS.
- If retry fails, wait 300 seconds (the value of *Long retry timer*), retry the primary DLUS, and if this retry fails, retry the backup DLUS.
- If retries fail, continue to retry the primary and backup DLUS, waiting 300 seconds between retry sequences, for as long as the DSPU is requesting ACTPU.
- For all other cases of pipe failure, DLUR will try the primary DLUS and then the backup DLUS immediately. If this fails, DLUR will:
  1. Wait for the amount of time specified by the minimum of the *short retry timer* and the *Delay before initiating retries* parameters.
  2. Attempt to reach the primary DLUS.
  3. If the attempt to reach the primary DLUS is unsuccessful, attempt to reach the backup DLUS
  4. If pipe activation continues to fail, DLUR will retry as described in steps 1 - 3 for the number of times specified in the *short retry count*.  
If the *short retry count* is exhausted, DLUR will retry as defined in steps 5 - 7 as long as the DSPU is requesting ACTPU.
  5. Wait for the amount of time specified by the *Long retry timer*

**Note:** If *Perform long retries to restore disrupted pipe* is No, no further retries will be attempted.

  6. Attempt to reach the primary DLUS.
  7. If the attempt to reach the primary DLUS is unsuccessful, attempt to reach the backup DLUS.

### Example:

- Assume the following parameter values:
  - *Delay before initiating retries* = 120 sec
  - *Perform short retries to restore disrupted pipe* = yes
  - *Short retry timer* = 60 sec
  - *Short retry count* = 2



- Perform long retries to restore disrupted pipe = yes
- Long retry timer = 300 sec
- Pipe activation fails.
- Retry the primary and backup DLUS immediately.
- If this retry fails, wait 60 seconds (the value of *Short retry timer*).
- Retry the primary DLUS. If this retry fails, retry the backup DLUS. This is attempt #1 of the *Short retry count*.
- If this fails, wait 60 seconds (the value of *Short retry timer*).
- Retry the primary DLUS, and then the backup DLUS. This is attempt #2 *Short retry count*. *Short retry count* is now exhausted.
- If the retry still fails, wait 300 seconds (the value of *Long retry timer*). Then retry the primary DLUS. If this retry attempt fails, retry the backup DLUS.
- As long as the retry fails, continue to retry the primary and the backup DLUS, waiting 300 seconds between retry sequences, for as long as the DSPU is requesting ACTPU.

## APPN Implementation on the Router Using DLSw

The router also supports APPN over DLSw for connectivity to nodes through a remote DLSw partner. An example is shown in Figure 3. This support allows customers with DLSw configurations to migrate their networks to 2212.

**Note:** It is recommended to use APPN over direct DLCs when available instead of APPN over DLSw.

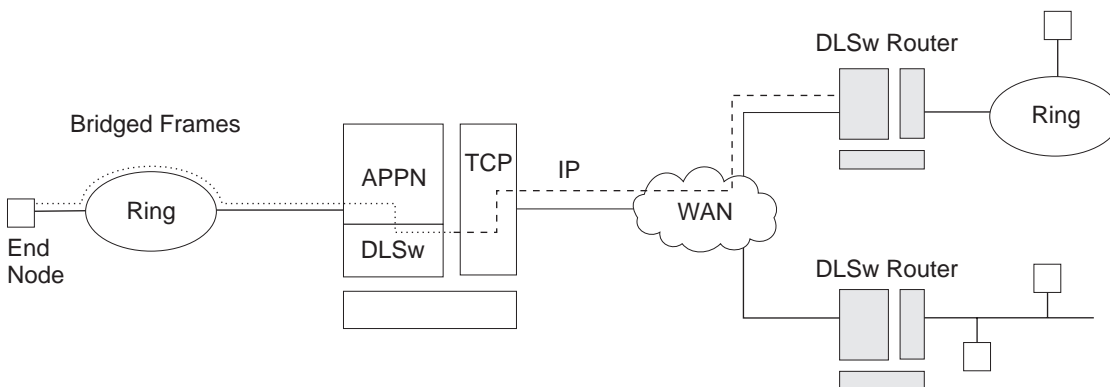

Figure 3. Data Flow in an APPN Configuration Using DLSw Port

APPN configuration restrictions using DLSw:

- Connectivity through remote DLSw partners only
- Only 1 DLSw port per router
- Use of a locally administered MAC address
- HPR is not supported on DLSw ports
- DLSw ports cannot be members of connection networks
- Parallel TGs are not supported on DLSw ports

See “Configuring the Router as an APPN Network Node” on page 27 to configure APPN using DLSw.

## How APPN Uses DLSw ports to Transport Data

When APPN is configured on the router to use Data Link Switching (DLSw) port, DLSw is used to provide a connection-oriented interface (802.2 LLC type 2) between the APPN component in the router and APPN nodes and LEN end nodes attached to a remote DLSw partner.

When configuring a DLSw port for APPN on the router, you assign the network node a unique MAC and SAP address pair that enables it to communicate with DLSw. The MAC address for the network node is locally administered and must not correspond to any physical MAC address in the DLSw network.

## APPN Frame Relay BAN Connection Network Implementation

The implementation of an APPN Frame Relay BAN connection network allows you to define an APPN frame relay port that supports the bridged frame relay format (BAN) to a connection network.

A shared-access transport facility (SATF) is a transmission facility, such as token-ring or Ethernet, in which nodes attached to the SATF can achieve any-to-any connectivity. This any-to-any connectivity allows direct connections between two nodes, eliminating routing through intermediate network nodes and the corresponding data traversing the SATF many times. TGs must be defined on each node to all other nodes in order to achieve this direct connectivity.

The SATF shown in Figure 4 illustrates that the APPN NN in the router must define a link station to each node on the token-ring in order to initiate a connection to each node on the token-ring. The APPN NN must know the DLCI address for the frame relay link and the MAC address of each node on the token-ring. If the nodes on the token-ring want to initiate a connection to the APPN NN, they must define a link station in the APPN NN in the device and specify:

- BAN DLCI MAC address if the device connecting the token-ring to the frame relay network is performing the BAN function
- The Boundary Node Identifier MAC address if the device connecting the token-ring to the frame relay network is a bridge

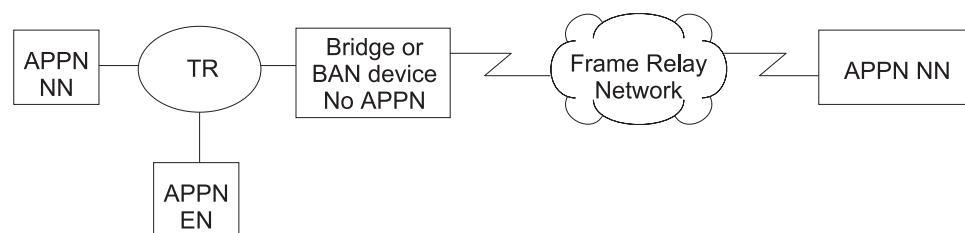

Figure 4. Logical View with Frame Relay Bridged Frame/BAN Connection Network Support

**Note:** In this diagram and in all the following Frame Relay BAN diagrams, the APPN resides in the 2212.

Defining connections between all possible pairs of nodes attached to the SATF results in a large number of definitions and a large number of topology database update flows on the network. APPN allows nodes to become members of a connection network to represent their attachment to the SATF.

Figure 5 shows all nodes as members of the same connection network. Nodes use the connection network to establish communication with all other nodes, removing the necessity of creating connections to all other nodes on the SATF. To become a member of a connection network, an APPN node's port must be attached to a connection network by defining a connection network interface. When the port is activated, a connection network TG is created by the APPN component to a Virtual Routing Node (VRN). This TG identifies the direct connection from the port to the connection network. The CP name of the VRN is the connection network name.

Since the connectivity is represented by a TG from a given node to a VRN, normal topology and routing services (TRS) can be used by the network node server to calculate the direct path between any two nodes attached to the connection network. DLC signaling information is returned from the destination node during the normal locate process to enable the origin node to establish a connection directly to the destination node.

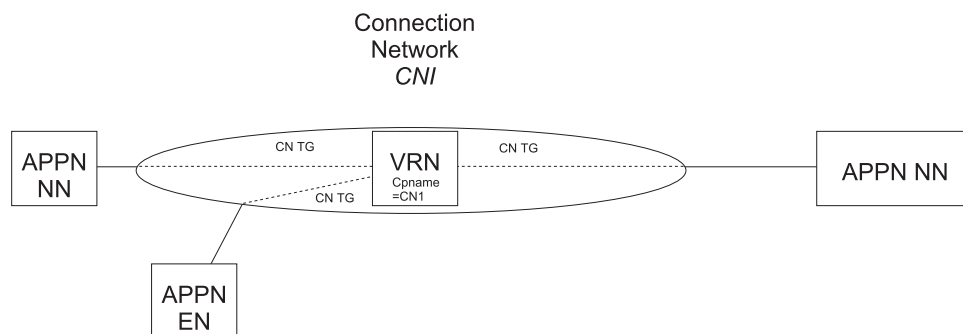

Figure 5. APPN Frame Relay Bridged Frame/BAN Connection Network

The following are limitations on using APPN Frame Relay BAN connection networks:

- The same connection network can be defined on only one SATF.
- All frame relay ports belonging to the same connection network on the router must use the same DLCI number to connect to the frame relay network.
- When bridging is used instead of BAN, all frame relay ports belonging to the same connection network on the router must have the same BNI MAC address/SAP pair defined.
- CP-CP sessions cannot be established over links established through a connection network.

### Sample APPN Frame Relay BAN Connection Network Definitions

#### Example 1

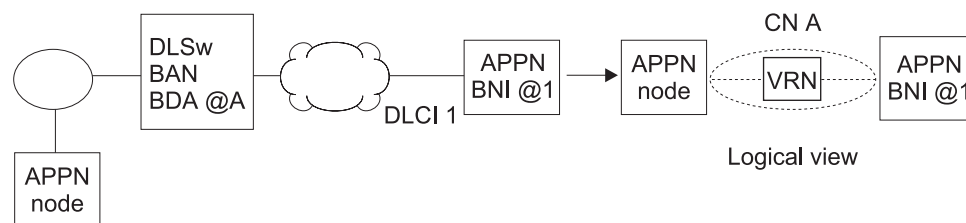

Figure 6. Single Connection Network using BAN with 1 Frame Relay Port

## APPN

**Note:** The BDA address must be defined on the connection network definition.

### Example 2

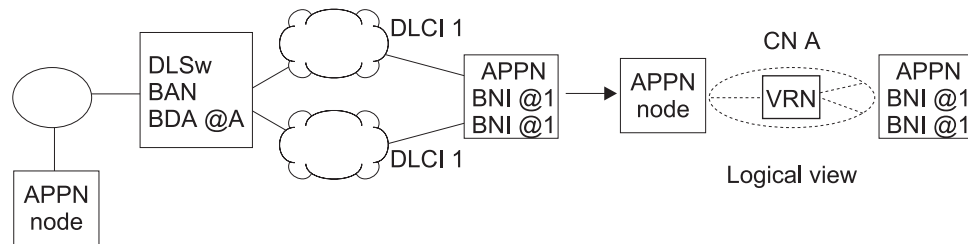

Figure 7. Single Connection Network using BAN with Multiple Frame Relay Ports

#### Notes:

1. The same DLCI number must be specified on both ports.
2. The BDA address must be defined on the connection network definition.
3. The BNI addressees on both ports can be the same or different.
4. If the APPN node initiates the connection to the device, the APPN port that gets chosen for the connection is dependent upon which port responds first to the test frame.

### Example 3

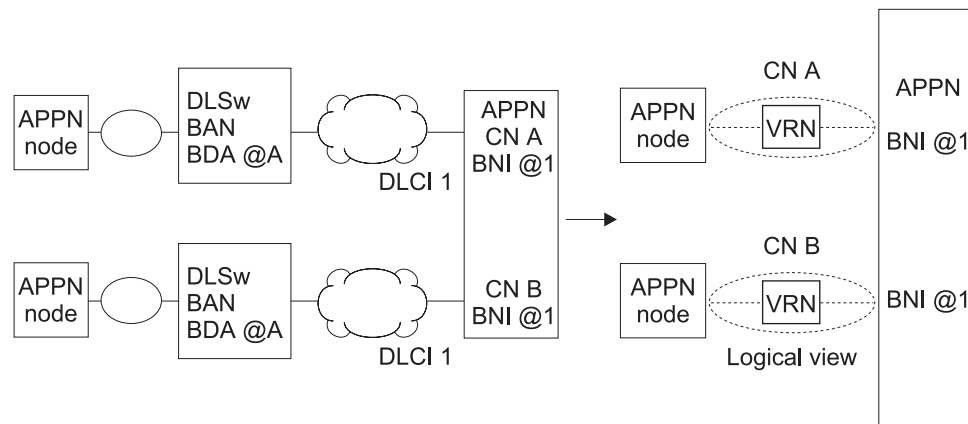

Figure 8. Multiple Connection Networks using BAN

#### Notes:

1. This configuration requires two connection network definitions since there are two SATFs.
2. The DLCI number specified on the ports can be the same or different.
3. The BDA MAC address must be defined on the connection network definition.
4. The BNI MAC address specified on the ports can be the same or different.

### Example 4

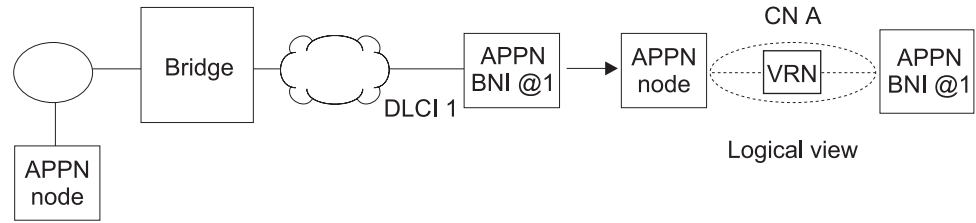

Figure 9. Single Connection Network using Bridging with One Frame Relay Port

**Notes:**

1. The BDA address is not defined on the connection network definition.

**Example 5**

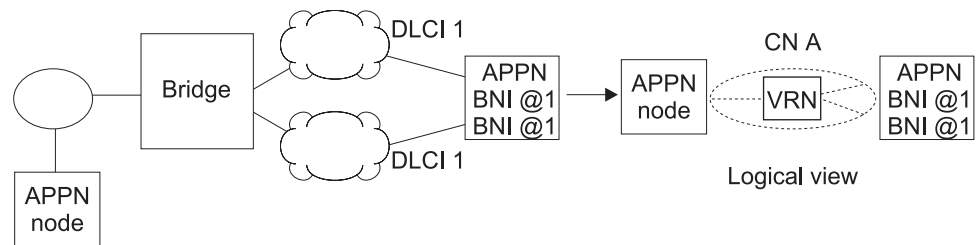

Figure 10. Single Connection Network Using Bridging with Multiple Frame Relay Ports

**Notes:**

1. The same DLCI number must be specified on both ports.
2. The same BNI MAC address/SAP pair must be specified on both ports.
3. No BDA MAC address is specified on the connection network definition.
4. If the APPN node initiates the connection to the device, the APPN port chosen for the connection depends upon which port responds first to the test frame.

**Example 6**

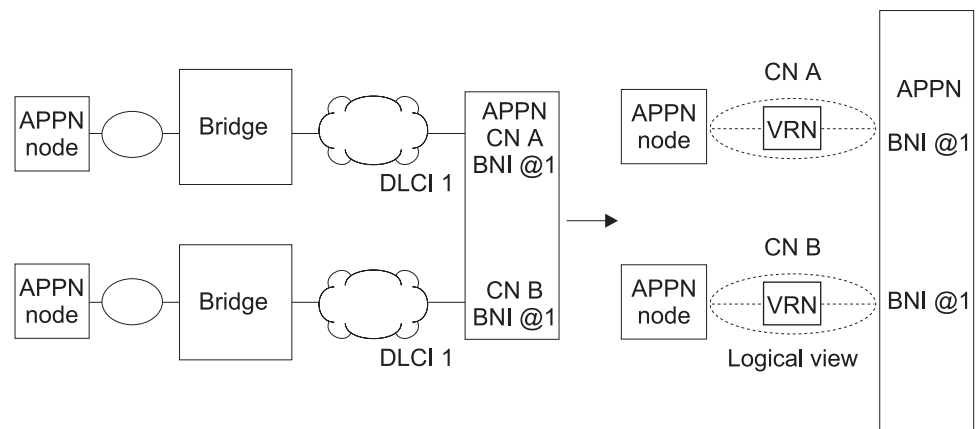

Figure 11. Multiple Connection Networks Using Bridging

**Notes:**

1. This configuration requires two connection network definitions since there are two SATFs.

## APPN

2. The DLCI number specified on the ports can be the same or different.
3. The BDA MAC address is not defined on the connection network definition.
4. The BNI MAC address/SAP pair specified on the ports can be the same or different.

## Port Level Parameter Lists

Use the following tables to configure APPN ports:

- “Port Configuration” on page 123
- “Port Definition” on page 127
- “Port Default TG Characteristics” on page 132
- “Port default LLC Characteristics” on page 137

## Link Level Parameter Lists

Use the following tables to configure APPN link stations:

- “HPR Defaults” on page 139
- “Link Station - Detail” on page 141
- “Modify TG Characteristics” on page 150
- “Modify Dependent LU Server” on page 153
- “Modify LLC Characteristics” on page 154
- “Modify HPR Defaults” on page 156

## LU Parameter List

Use the following table to configure an LU:

- “LEN End Node LU Name” on page 158

## Node Level Parameter Lists

Use the following tables to configure an APPN node:

- “Local node basic characteristics” on page 81
- “High Performance Routing (HPR)” on page 86
- “HPR Timer and Retry Options” on page 86
- “Dependent LU Requester” on page 90
- “Connection Network - Detail” on page 159
- “TG Characteristics (Connection Network)” on page 161
- “APPN COS - Additional port to CN” on page 166
- “Node Level Traces” on page 99
- “Interprocess Signals Traces” on page 105
- “Module Entry and Exit Traces” on page 109
- “General Component Level Traces” on page 111

- “APPN Node Management” on page 118
- “TN3270E” on page 175
- Table 34 on page 169
- Table 35 on page 172

---

## APPN Configuration Notes

The following examples show special parameters to consider when configuring various features to transport APPN traffic.

**Note:** These examples show sample output. The output you see may not appear exactly like the output shown here.

**Note:** In some configuration examples, the results of a **talk 6 list** command may show more configuration than is actually presented in the sample. However, the sample will show all of the configuration that is unique.

## Configuring a Permanent Circuit Using ISDN

This example is a configuration of a permanent circuit using frame relay over ISDN from node 21 to node 1.

**Note:** You configure a permanent circuit by setting the idle timer value to 0.

```
*****
**** Configuring a PERMANENT circuit via ISDN from NN21 to NN1
**** Using Frame Relay over ISDN
*****

Config>n 6
Circuit configuration
FR Config>li all

Base net = 3
Destination name = 2212-01
Circuit priority = 8
Destination address: subaddress = 99195551234:

Inbound destination name = 2212-01
Inbound dst address: subaddress = 99195551000:

Inbound calls = allowed
Idle timer = 0 (fixed circuit)
SelfTest Delay Timer = 150 ms

FR Config>ex

*****
**** Verify that a FR PVC is defined to NN1. This is required for APPN
*****

Config>n 6
Circuit configuration
FR Config>en
Frame Relay user configuration
FR Config>li perm

Maximum PVCs allowable = 64
Total PVCs configured = 1

Circuit      Circuit      Circuit      CIR      Burst      Excess
Name         Number      Type         in bps   Size       Burst
-----
2212-21-i6  16         Permanent   64000    64000     0
= circuit is required and belongs to a required PVC group

FR Config>ex
Config>p appn
APPN user configuration
```

# APPN

```

APPN config>add p
APPN Port
Link Type: (P)PP, (F)RAME RELAY, (E)THERNET, (T)OKEN RING,
(M)PC, (S)DLC, (X)25, (FD)DI, (D)LSw, (A)TM, (IP) [ ] ? f
Interface number(Default 0): [0] ? 6
Port name (Max 8 characters) [FR006] ?
Enable APPN on this port (Y)es (N)o [Y] ?
Port Definition
Service any node: (Y)es (N)o [Y] ?
Limited resource: (Y)es (N)o [N] ?
High performance routing: (Y)es (N)o [Y] ?
Maximum BTU size (768-2044) [2044] ?
Maximum number of link stations (1-976) [512] ?
Percent of link stations reserved for incoming calls (0-100) [0] ?
Percent of link stations reserved for outgoing calls (0-100) [0] ?
Local SAP address (04-EC) [4] ?
Support bridged formatted frames: (Y)es (N)o [N] ?
Edit TG Characteristics: (Y)es (N)o [N] ?
Edit LLC Characteristics: (Y)es (N)o [N] ?
Edit HPR defaults: (Y)es (N)o [N] ?
Write this record? [Y] ?
The record has been written.
APPN config>add li
APPN Station
Port name for the link station [ ] ? fr006
Station name (Max 8 characters) [ ] ? tonnlisdn
Station name (Max 8 characters) [ ] ? tonnlis
Limited resource: (Y)es (N)o [N] ?
Activate link automatically (Y)es (N)o [Y] ?
DLCI number for link (16-1007) [16] ?
Adjacent node type: 0 = APPN network node, 1 = APPN end node
2 = LEN end node, 3 = PU 2.0 node [0] ?
High performance routing: (Y)es (N)o [Y] ?
Edit Dependent LU Server: (Y)es (N)o [N] ?
Allow CP-CP sessions on this link (Y)es (N)o [Y] ?
CP-CP session level security (Y)es (N)o [N] ?
Configure CP name of adjacent node: (Y)es (N)o [N] ?
Edit TG Characteristics: (Y)es (N)o [N] ?
Edit LLC Characteristics: (Y)es (N)o [N] ?
Edit HPR defaults: (Y)es (N)o [N] ?
Write this record? [Y] ?
The record has been written.
APPN config>ex
APPN config>li all
NODE:
NETWORK ID: STFNET
CONTROL POINT NAME: NN21
XID: 00000
APPN ENABLED: YES
MAX SHARED MEMORY: 4096
MAX CACHED: 4000
DLUR:
DLUR ENABLED: YES
PRIMARY DLUS NAME: NETB.MVSC
CONNECTION NETWORK:
CN NAME          LINK TYPE  PORT INTERFACES
-----
COS:
COS NAME
-----
BATCH
BATCHSC
CONNECT
INTER
INTERSC
CPSVCMG
SNASVCMG
USRBAT
USRNOT
MODE:
MODE NAME  COS NAME
-----
#USRBAT   #USRBAT
#USRNOT   #USRNOT
PORT:
INTF      PORT      LINK      HPR      SERVICE  PORT
NUMBER   NAME      TYPE      ENABLED  ANY      ENABLED
-----
0         TR000    IBMTRNET  YES      YES      YES
1         SDLC001  SDLC      NO       YES      YES
254      DLS254   DLS       NO       YES      YES
6         FR006    FR        YES      YES      YES
STATION:
STATION   PORT      DESTINATION  HPR  ALLOW  ADJ
NAME      NAME      ADDRESS      ENABLED  CP-CP  TYPE
-----

```



```

      TONN25  TR000  0004ACA2A407  YES  YES  0
      TONN31  TR000  4FFF00001031  YES  NO   0
      SDLC1   SDLC001 C1      NO   NO   2
      TONN103 DLS254  400000000103  NO   NO   0
      TONN1IS  FR006  16      YES  YES  0 4
LU NAME:
-----
      LU NAME          STATION NAME      CP NAME
-----
APPN config>

```

**Note:**

- 1 Idle timer = 0 gives a fixed circuit
- 2 Frame relay PVC is defined
- 3 This is the ISDN port
- 4 This is the link station

## Configuring APPN Over Dial on Demand Circuits

APPN is supported over dial on demand circuits for the following DLC types:

- APPN/PPP/ISDN
- APPN/FR/ISDN
- APPN/PPP/V.25 BIS
- APPN/PPP/V.34

Refer to the *Software User's Guide* for additional information about dial on demand circuits.

### PU 2.1 Node Considerations

When configuring an APPN link station for PU 2.1 nodes over a Dial on Demand link, you should specify *yes* for the *limited resource* link station parameter. This allows APPN to:

- Consider this link as a viable link to be used for route computation, even though the link is not actually active. The link will automatically become active during LU-LU session activation for a session needing to use it.
- Deactivate the link station when there are no active sessions using this link.

You should not configure CP-CP sessions over a dial on demand link. CP-CP sessions are persistent sessions. That is, they should remain active as long as the link is active. Since the active session count will not go to zero in this case, the link will remain active.

**Note:** If you specify *yes* for the *limited resource* parameter for a PU 2.1 node, you must specify an adjacent CPNAME and a TG number in the range of 1 to 20.

### PU 2.0 Node Considerations

When configuring an APPN link station for PU 2.0 nodes over a Dial on Demand link, you can specify *yes* for the *limited resource* link station parameter. This allows APPN to deactivate the link station when there are no active sessions using it.

**Note:** If *limited resource* is *yes*, link activation for this link station must be initiated by either the DSPU (the PU 2.0) or by VTAM.

## Considerations When Using DLUR for T2.0 or T2.1 Devices

For T2.0 or T2.1 nodes utilizing DLUR for dependent session traffic, an SSCP-PU and an SSCP-LU session must be active in order to establish an LU-LU session. These sessions are included in the session count for the link to the DSPU. Therefore, if *limited resource* is yes, the link will remain active as long as the SSCP-PU session is active or LU-LU sessions are active over this link.

If you specify no for the *limited resource* parameter, link deactivation is controlled by the node that initiated the connection.

If the link to the DSPU was activated due to the DSPU calling into the DLUR node or the DLUR node calling out to the DSPU (i.e. the link station to the DSPU has been configured in the router and *activate link automatically* is yes), when the active session count goes to zero the link is deactivated by APPN DLUR only if the DSPU requested DACTPU. In this case, if the DLUS sends a DACTPU request to DLUR, DLUR will deactivate the SSCP-PU session. However, it will not deactivate the link to the DSPU. DLUR will attempt to reestablish the SSCP-PU session to the DLUS or the backup DLUS until it is successful or until the DSPU no longer needs this session.

If the link to the DSPU was activated by the DLUS and the session count goes to zero, the link is deactivated by APPN DLUR only if the DLUS sends a DACTPU request to DLUR.

The following is a dial on demand configuration example. This configuration is similar to the ISDN permanent connection except:

- You must specify that the link is a limited resource.
- You must define the adjacent CP name.
- You must specify a TG number.

You configure both sides of the communication link the same way.

**Note:** If you allow CP-CP sessions on this link, the link will not disconnect.

```
*t 6
Gateway user configuration
Config>
*****
**** This is the NN6 configuration for a NN6---NN15 dial on demand link.
**** The NN15 config will look just like this.
**** interface 9 is a Dial On Demand link with destination = NN15
*****
Config>n 9
Circuit configuration
FR Config>li a11

Base net                = 6
Destination name        = 2212-15
Circuit priority        = 8

Inbound destination name = 2212-15

Inbound calls           = allowed
Idle timer              = 60 sec
SelfTest Delay Timer    = 150 ms

FR Config>ex

*****
**** Configure APPN Port for the Interface
*****

Config>p appn
APPN user configuration
```

```

APPN config>add p
APPN Port
Link Type: (P)PP, (F)RAME RELAY, (E)THERNET, (T)OKEN RING,
(M)PC, (S)DLC, (X)25, (FD)DI, (D)LSw, (A)TM, (IP) [ ] ? p
Interface number(Default 0): [0 ] ? 9
Port name (Max 8 characters) [PPP009 ] ?

Enable APPN on this port (Y)es (N)o [Y ] ?
Port Definition
Service any node: (Y)es (N)o [Y ] ?
Limited resource: (Y)es (N)o [Y ] ? 2
**** note that limited resource = YES
High performance routing: (Y)es (N)o [Y ] ?
Maximum BTU size (768-2044) [2044 ] ?
Local SAP address (04-EC) [4 ] ?
Edit TG Characteristics: (Y)es (N)o [N ] ?
Edit LLC Characteristics: (Y)es (N)o [N ] ?
Edit HPR defaults: (Y)es (N)o [N ] ?
Write this record? [Y ] ?
The record has been written.

*****
**** Configure the linkstation for the DOD link to NN15
*****
APPN config>add li
APPN Station
Port name for the link station [ ] ? ppp009
Station name (Max 8 characters) [ ] ? to15dod
Limited resource: (Y)es (N)o [Y ] ? 2
**** < note limited resource= YES
TG Number (1-20) [1 ] ? 3
**** < note TG number is required input for limited resource
Adjacent node type: 0 = APPN network node, 1 = APPN end node
2 = LEN end node [0 ] ?
High performance routing: (Y)es (N)o [Y ] ?
Allow CP-CP sessions on this link (Y)es (N)o [Y ] ? N 4
**** < Be sure to NOT allow CP-CP sessions, or link won't hang up
Fully-qualified CP name of adjacent node (netID.CPname) [ ] ? stfnet.NN15
**** < Adjacent node name required for limited resource links
Edit TG Characteristics: (Y)es (N)o [N ] ?
Edit LLC Characteristics: (Y)es (N)o [N ] ?
Edit HPR defaults: (Y)es (N)o [N ] ?
Write this record? [Y ] ?
The record has been written.
APPN config>li all
NODE:
NETWORK ID: STFNET
CONTROL POINT NAME: NN6
XID: 00000
APPN ENABLED: YES
MAX SHARED MEMORY: 4096
MAX CACHED: 4000
DLUR:
DLUR ENABLED: YES
PRIMARY DLUS NAME: NETB.MVSC

CONNECTION NETWORK:
      CN NAME      LINK TYPE  PORT INTERFACES
-----
COS:
COS NAME
-----
BATCH
BATCHSC
CONNECT
INTER
INTERSC
CPSVCMG
SNASVCMG
USRBAT
USRNOT

MODE:
MODE NAME  COS NAME
-----
USRBAT    USRBAT
USRNOT    USRNOT

PORT:
INTF      PORT      LINK      HPR      SERVICE  PORT
NUMBER   NAME      TYPE      ENABLED  ANY      ENABLED
-----

```

## APPN

0	TR000	IBMTRNET	YES	YES	YES	
1	PPP001	PPP	YES	YES	YES	
2	SS	SDLC	NO	YES	YES	
3		SDLC	NO	YES	NO	
4		PPP	YES	YES	NO	
5	TR005	IBMTRNET	YES	YES	YES	
254		DLS	NO	YES	NO	
17	PPP017	PPP	YES	YES	YES	
9	PPP009	PPP	YES	YES	YES	6

STATION:	STATION NAME	PORT NAME	DESTINATION ADDRESS	HPR ENABLED	ALLOW CP-CP	ADJ NODE TYPE
	TONN1	TR000	0004AC4E7505	YES	YES	1
	TONN2	TR000	550020004020	YES	YES	1
	TONN9	TR000	0004AC4E951D	YES	YES	1
	TOPC4	TR000	0004AC9416B4	YES	YES	1
	TOVTAM1	TR000	400000003888	YES	YES	1
	TONN35	PPP001	000000000000	YES	YES	0
	T015DOD	PPP009	000000000000	YES	NO	0

LU NAME:	LU NAME	STATION NAME	CP NAME

### Note:

- 1 Idle timer > 0 means dial on demand
- 2 This is a limited resource
- 3 TG number is required for a limited resource
- 4 Do not allow CP-CP sessions on this link
- 5 Provide a fully-qualified CP name
- 6 This is the port
- 7 This is the link station

## Configuring WAN Reroute

WAN reroute lets you set up an alternate route so that if a primary link fails, the router automatically initiates a new connection to the destination through the alternate route.

You can use any type of link as the alternate link and any type of link as the primary link. The alternate link does not need to be connected to the same end point as the primary link.

If HPR is used on the primary link and alternate link, when the primary link fails, HPR's Non-disruptive Path Switch function will automatically reroute traffic to the alternate link without disrupting end user sessions.

In this configuration example, the router performing the WAN reroute function is configured with two APPN link station definitions; one link station is defined over the primary interface and the other is over the alternate interface. The destination router needs to have APPN enabled on the port. If the destination router has a link station defined, that link station should not try to bring up the connection in order to avoid extra traffic.

In this example, frame relay is the primary route from NN22 to NN6.

```
*****
**** The configuration is NN22---primary FR
****                               ---Alternate WRR to NN6
*****
****
**** This is the NN22 configuration
*****
```

```

Ifc 0 Token Ring                Slot: 1  Port: 1
Ifc 1 V.35/V.36 Frame Relay    Slot: 8  Port: 0
Ifc 2 V.35/V.36 Frame Relay    Slot: 8  Port: 1
Ifc 3 ISDN Primary T1/J1       Slot: 7  Port: 1
Ifc 4 PPP Dial Circuit          (Disabled)
Ifc 5 PPP Dial Circuit          (Disabled)
Ifc 6 Frame Relay Dial Circuit  (Disabled)
*****
* Ifc 4 is the ALTERNATE with Ifc 1 configured as PRIMARY.
* Note that interface 4 should be 'Disabled' here.
* Wan Reroute function will 'Enable' it when the
* Primary fails
*
* NN6 (2212-06) is going to be the destination of the Wan Reroute
*****
Config>n 4
Circuit configuration
FR Config>li

Base net                = 3
Destination name        = 2212-06
Circuit priority        = 8
Destination address: subaddress = 99199991201:

Outbound calls          = allowed
Idle timer              = 0 (fixed circuit)
SelfTest Delay Timer    = 150 ms

Config>ex
*****
*
**** Configure the Wan Reroute Primary and Alternate circuit
*
*****
Config>fea wan 4
WAN Restoral user configuration
WRS Config>en wrs
WRS Config>add alt
Alternate interface number [0] ? 4
Primary interface number [0] ? 1
WRS Config>li all

WAN Restoral is enabled.
Default Stabilization Time: 0 seconds
Default First Stabilization Time: 0 seconds

[No Primary-Secondary pairs defined ]

```

Primary Interface	Alternate Interface	Enabled	Stab	Stab	Start	Stop
	Alt.	1st	Subseq	TOD	Revert	Back
1 - WAN Frame Re	4 - PPP Dial Circuit	No	dflt	dflt	Not Set	Not Set

```

*****
*
**** Set Default and first stabilization times
*
*****
WRS Config>set default firs 30
WRS Config>set def stab 10
WRS Config>li all
WAN Restoral is enabled.
Default Stabilization Time: 10 seconds
Default First Stabilization Time: 30 seconds
[No Primary-Secondary pairs defined ]
Alt. 1st Subseq TOD Revert Back

```

# APPN

Primary Interface	Alternate Interface	Enabled	Stab	Stab	Start	Stop
1 - WAN Frame Re	4 - PPP Dial Circuit	No	df1t	df1t	Not Set	Not Set

```
WRS Config>en alt
Alternate interface number [0] ? 4
WRS Config>ex
```

```
*****
*
*Configure APPN PORTS and LINKSTATIONS for the
*ALTERNATE and PRIMARY interfaces
*****
```

```
Config>p appn
APPN user configuration
APPN config>add p 0
APPN Port
Link Type: (P)PP, (F)RAME RELAY, (E)THERNET, (T)OKEN RING,
(M)PC, (S)DLC, (X)25, (FD)DI, (D)LSw, (A)TM, (IP) [ ] ? p
Interface number(Default 0): [0] ? 4
Port name (Max 8 characters) [PPP004] ?
Enable APPN on this port (Y)es (N)o [Y] ?
Port Definition
Service any node: (Y)es (N)o [Y] ?
Limited resource: (Y)es (N)o [N] ?
High performance routing: (Y)es (N)o [Y] ?
Maximum BTU size (768-2044) [2044] ?
Local SAP address (04-EC) [4] ?
Edit TG Characteristics: (Y)es (N)o [N] ?
Edit LLC Characteristics: (Y)es (N)o [N] ?
Edit HPR defaults: (Y)es (N)o [N] ?
Write this record? [Y] ?
The record has been written.
```

```
APPN config>add li 0
APPN Station
Port name for the link station [ ] ? ppp004
Station name (Max 8 characters) [ ] ? tonN6WRR
Limited resource: (Y)es (N)o [N] ?
Activate link automatically (Y)es (N)o [Y] ?
Adjacent node type: 0 = APPN network node, 1 = APPN end node
2 = LEN end node [0] ?
High performance routing: (Y)es (N)o [Y] ?
Allow CP-CP sessions on this link (Y)es (N)o [Y] ?
CP-CP session level security (Y)es (N)o [N] ?
Configure CP name of adjacent node: (Y)es (N)o [N] ?
Edit TG Characteristics: (Y)es (N)o [N] ?
Edit LLC Characteristics: (Y)es (N)o [N] ?
Edit HPR defaults: (Y)es (N)o [N] ?
Write this record? [Y] ?
The record has been written.
```

```
APPN config>add li 0
APPN Station
Port name for the link station [ ] ? fr001
Station name (Max 8 characters) [ ] ? tonn1pri
Activate link automatically (Y)es (N)o [Y] ?
DLCI number for link (16-1007) [16] ? 121
Adjacent node type: 0 = APPN network node, 1 = APPN end node
2 = LEN end node [0] ?
High performance routing: (Y)es (N)o [Y] ?
Allow CP-CP sessions on this link (Y)es (N)o [Y] ?
CP-CP session level security (Y)es (N)o [N] ?
Configure CP name of adjacent node: (Y)es (N)o [N] ?
Edit TG Characteristics: (Y)es (N)o [N] ?
Edit LLC Characteristics: (Y)es (N)o [N] ?
Edit HPR defaults: (Y)es (N)o [N] ?
Write this record? [Y] ?
The record has been written.
```

```
APPN config>li all
NODE:
NETWORK ID: STFNET
CONTROL POINT NAME: NN22
XID: 00000
APPN ENABLED: YES
MAX SHARED MEMORY: 4096
MAX CACHED: 4000
DLUR:
DLUR ENABLED: NO
PRIMARY DLUS NAME:
CONNECTION NETWORK:
CN NAME LINK TYPE PORT INTERFACES
```

```

-----
COS:
COS NAME
-----
  BATCH
  BATCHSC
  CONNECT
  INTER
  INTERSC
  CPSVCMG
  SNASVCMG
  MODE NAME  COS NAME
-----
PORT:
  INTF  PORT  LINK  HPR  SERVICE  PORT
  NUMBER NAME  TYPE  ENABLED ANY  ENABLED
-----
   0    TR000  IBMTRNET  YES  YES  YES
**** < this is the Primary port
   1    FR001  FR  YES  YES  YES
**** < this is the alternate port
   4    PPP004  PPP  YES  YES  YES
STATION:
  STATION  PORT  DESTINATION  HPR  ALLOW  ADJ  NODE
  NAME     NAME  ADDRESS      ENABLED CP-CP  TYPE
-----
  TONN25   FR001  132          YES  YES   0
  TONN31   FR001  141          YES  NO    0
  TONN103  FR001  153          YES  NO    0
**** < this is the alternate to NN6
  TONN6WRR PPP004  000000000000  YES  YES   0
**** < this is the Primary to NN1
  TONN1PRI  FR001  121          YES  YES   0
LU NAME:
  LU NAME  STATION NAME  CP NAME
-----

```

APPN config> ex

```

*****
*****
*****
Config>
***** The configuration is NN22---primary FR
*****
*****
** This is the NN6 configuration which is the destination side for the
* NN22 Wan Reroute
* interface 17 has the ISDN lid for 2212-22 so when NN22 calls into NN6,
* it will map to interface 17
*
*****

```

```

[1] Config> n 17
Circuit configuration
FR Config>fea li all

Base net = 6
Destination name = 2212-22
Circuit priority = 8

Inbound destination name = 2212-22

Inbound calls = allowed
Idle timer = 0 (fixed circuit)
SelfTest Delay Timer = 150 ms

FR Config>ex
**** on this side, the interface must be ENABLED all the time
Config>ena in 17
Interface enabled successfully

```

```

*****
* Define the APPN PORT; NN22 will call into NN6 and dynamically create
* the linkstation when NN22 does a Wan Reroute.
*
*****
Config>p appn
APPN user configuration

```

# APPN

```

APPN config>add p 12
APPN Port
Link Type: (P)PP, (F)RAME RELAY, (E)THERNET, (T)OKEN RING,
(M)PC, (S)DLC, (X)25, (FD)DI, (D)LSw, (A)TM, (IP) [ ] ? p
Interface number(Default 0): [0 ] ? 17
Port name (Max 8 characters) [PPP017 ] ?
Enable APPN on this port (Y)es (N)o [Y ] ?

Port Definition
Service any node: (Y)es (N)o [Y ] ?
Limited resource: (Y)es (N)o [N ] ?
High performance routing: (Y)es (N)o [Y ] ?
Maximum BTU size (768-2044) [2044 ] ?
Local SAP address (04-EC) [4 ] ?
Edit TG Characteristics: (Y)es (N)o [N ] ?
Edit LLC Characteristics: (Y)es (N)o [N ] ?
Edit HPR defaults: (Y)es (N)o [N ] ?
Write this record? [Y ] ?
The record has been written.
APPN config>li al
NODE:
NETWORK ID: STFNET
CONTROL POINT NAME: NN6
XID: 00000
APPN ENABLED: YES
MAX SHARED MEMORY: 4096
MAX CACHED: 4000
DLUR:
DLUR ENABLED: YES
PRIMARY DLUS NAME: NETB.MVSC
CONNECTION NETWORK:
-----
      CN NAME      LINK TYPE  PORT INTERFACES
-----
COS:
COS NAME
-----
      BATCH
      BATCHSC
      CONNECT
      INTER
      INTERSC
      CPSVCMG
      SNASVCMG
      USRNOT
MODE:
MODE NAME  COS NAME
-----
      USRBAT      USRBAT
      USRNOT      USRNOT

PORT:
INTF  PORT  LINK  HPR  SERVICE  PORT
NUMBER NAME  TYPE  ENABLED ANY  ENABLED
-----
      0      TR000  IBMTRNET  YES  YES  YES
      1      PPP001  PPP  YES  YES  YES
      2      SS      SDLC  NO   YES  YES
      3      SDLC  NO   YES  NO
      4      PPP  YES  YES  NO
      5      TR005  IBMTRNET  YES  YES  YES
      254    DLS  NO   YES  NO
      17    PPP017  PPP  YES  YES  YES

STATION:
STATION  PORT  DESTINATION  HPR  ALLOW  ADJ  NODE
NAME     NAME  ADDRESS      ENABLED CP-CP  TYPE
-----
      TONN1  TR000  0004AC4E7505  YES  YES  1
      TONN2  TR000  550020004020  YES  YES  1
      TONN9  TR000  0004AC4E951D  YES  YES  1
      TOPC4  TR000  0004AC9416B4  YES  YES  1
      TOVTAM1 TR000  400000003888  YES  YES  1
      TONN35  PPP001  000000000000  YES  YES  0

LU NAME:
LU NAME      STATION NAME      CP NAME
-----

```

## Note:

**1** The primary route is interface 1, frame relay



- 2 The alternate route is interface 4 and is disabled
- 3 Destination of WAN reroute is NN6
- 4 Configure WAN reroute primary and alternate
- 5 Add the APPN port to NN22
- 6 Link station on APPN port (NN22)
- 7 Primary port
- 8 Alternate port
- 9 Alternate station to NN6
- 10 Primary station to NN6
- 11 Destination configuration
- 12 APPN port on destination; link station will be dynamically created when WAN reroute occurs.

## Configuring WAN Restoral

The following example shows APPN over a primary PPP link. For APPN, no unique definitions are needed. Both sides of the communication link are enabled for WAN restoral and are similarly configured.

```
*****
*** Configuration of NN6 with a Wan Restoral link to NN35
*** interface 1 is the primary, interface 8 is the Secondary
*** NN35 must also have Wan Restoral configured for its primary/secondary
*** interfaces
**** Note that for APPN, there are NO unique definitions needed.
*****
```

```
Circuit configuration
FR Config>li a1
```

```
Base net                = 6
Destination name        = 2212-35
Circuit priority        = 8

Inbound destination name = 2212-35

Inbound calls           = allowed
Idle timer              = 0 (fixed circuit)
SelfTest Delay Timer    = 150 ms
```

```
FR Config>ex
Config>fea wan
WAN Restoral user configuration
WRS Config>li a11
```

```
WAN Restoral is enabled.
Default Stabilization Time: 0 seconds
Default First Stabilization Time: 0 seconds
```

Primary Interface	Secondary Interface	Secondary Enabled
1 - WAN PPP	8 - PPP Dial Circuit	Yes
[No Primary-Alternate pairs defined ]		

```
WRS Config>ex
Config>p appn
APPN user configuration
APPN config>li a1
NODE:
NETWORK ID: STFNET
CONTROL POINT NAME: NN6
XID: 00000
APPN ENABLED: YES
MAX SHARED MEMORY: 4096
MAX CACHED: 4000
DLUR:
DLUR ENABLED: YES
PRIMARY DLUS NAME: NETB.MVSC
```

# APPN

```

CONNECTION NETWORK:
  CN NAME      LINK TYPE  PORT INTERFACES
-----
COS:
COS NAME
-----
  BATCH
  BATCHSC
  CONNECT
  INTER
  INTERSC
  CPSVCMG
  SNASVCMG
  USRBAT
  USRNOT
MODE:
  MODE NAME    COS NAME
-----
  USRBAT      USRBAT
  USRNOT      USRNOT
PORT:
  INTF        PORT      LINK      HPR      SERVICE  PORT
  NUMBER      NAME      TYPE      ENABLED  ANY      ENABLED
-----
  0           TR000    IBMTRNET  YES      YES      YES
**** < This is the port that will get backed up
  1           PPP001    PPP       YES      YES      YES  2
  2           SS      SDLC      NO       YES      YES
  3           SDLC      SDLC      NO       YES      NO
  4           PPP       PPP       YES      YES      NO
  5           TR005    IBMTRNET  YES      YES      YES
  254         DLS      DLS       NO       YES      NO
  17          PPP017    PPP       YES      YES      YES
  9           PPP009    PPP       YES      YES      YES

STATION:
  STATION     PORT      DESTINATION  HPR  ALLOW  ADJ  NODE
  NAME       NAME      ADDRESS      ENBLD CP-CP  TYPE
-----
  TONN1      TR000    0004AC4E7505  YES  YES    1
  TONN2      TR000    550020004020  YES  YES    1
  TONN9      TR000    0004AC4E951D  YES  YES    1
  TOPC4      TR000    0004AC9416B4  YES  YES    1
  TOVTAM1    TR000    400000003888  YES  YES    1
**** < this linkstation will get backed up
  TONN35     PPP001    000000000000  YES  YES    0  3
  T015D0D    PPP009    000000000000  YES  NO     0

LU NAME:
  LU NAME      STATION NAME      CP NAME
-----
APPN config>ex
Config>
*logout
Connection closed.

```

## Note:

- 1 WAN restoral is enabled on both sides.
- 2 Port that will get backed up
- 3 Link station that will get backed up

## Configuring V.25bis

The following is a sample V.25bis configuration that could be used when APPN traffic uses PPP over V.25bis:

```
Config> list device
```

```

Ifc 2 WAN V.25bis                CSR 81640, CSR2 80E00, vector 92
Ifc 0 Token Ring                  Slot: 1   Port: 1
Ifc 1 EIA-232E/V.24 PPP          Slot: 8   Port: 0
Ifc 2 EIA-232E/V.24 X.25        Slot: 8   Port: 1
Config>set data v25 2.
Config>list device

```

```

Ifc 0 Token Ring                Slot: 1  Port: 1
Ifc 1 EIA-232E/V.24 PPP        Slot: 8  Port: 0
Ifc 2 EIA-232E/V.24 V.25bis   Slot: 8  Port: 1
Config>add v25
Assign address name (1-23) chars []? brown
Assign network dial address (1-30 digits) []? 555-1211
Assign address name (1-23) chars []? gray
Assign network dial address (1-30 digits) []? 555-1212
Config>list v25

Address assigned name          Network Address
-----
brown                          555-1211
gray                           555-1212
Config>add device dial
Adding device as interface 3
Defaulting Data-link protocol to PPP
Use net 3 command to configure circuit parameters
Config>net 3
Circuit configuration
Circuit config: 3>list all.

Base net                        = 0
Destination name                =
Circuit priority                = 8

Outbound calls                  = allowed
Inbound calls                   = allowed
Idle timer                      = 60 sec
SelfTest Delay Timer           = 150 ms

Circuit config: 3>set net
Base net for this circuit [0]? 2
Circuit config: 3>set idle 0
Circuit config: 3>set dest
Assign destination address name []? brown
Circuit config: 3>list all

Base net                        = 2
Destination name                = brown
Circuit priority                = 8
Destination address: subaddress = 555-1211

Outbound calls                  = allowed
Inbound calls                   = allowed
Idle timer                      = 0 (fixed circuit)
SelfTest Delay Timer           = 150 ms

Circuit config: 3>ex
Config>net 2
V.25bis Data Link Configuration
V25bis Config>list all
V.25bis Configuration
Local Network Address Name     = Unassigned
No local addresses configured

Non-Responding addresses:
Retries                        = 1
Timeout                        = 0 seconds

Call timeouts:
Command Delay                  = 0 ms
Connect                        = 60 seconds
Disconnect                     = 2 seconds

Cable type                     = RS-232 DTE

Speed (bps)                    = 9600
V25bis Config>set local
Local network address name     []? gray
V25bis Config>list all
V.25bis Configuration
Local Network Address Name     = gray
Local Network Address          = 555-1212

```

## APPN

```
Non-Responding addresses:
Retries                   = 1
Timeout                   = 0 seconds

Call timeouts:
Command Delay             = 0 ms
Connect                   = 60 seconds
Disconnect                = 2 seconds

Cable type                = RS-232 DTE

Speed (bps)               = 9600
V25bis Config>
```

### Note:

- ❶ A non-zero value for Idle Timer results in a dial-on-demand link
- ❷ A zero value results in a leased link

## Configuring APPN Using SDLC

APPN supports the following SDLC stations:

- Primary point-to-point
- Secondary point-to-point
- Negotiable point-to-point
- Primary multipoint
- Secondary point-to-point (multi APPN link stations)

Using the **talk 5** command interface for SDLC, you can:

- Enable/disable a SDLC link
- Update SDLC station parameters.

In order to activate an APPN connection to the remote SDLC link station, you must configure and activate the APPN SDLC link station in the router. This enables the APPN link station in the router to receive an activation XID from the remote SDLC link station. This is different from other DLC types, such as Token ring or Ethernet, whose APPN link stations do not need to be explicitly defined for APPN in the router since APPN has the capability to dynamically define these types of link stations.

Refer to the Software User's Guide for additional information about SDLC network layer configuration.

```
*****
*
* The following examples show how to configure different SDLC stations.
*
*****
*Configuring a Primary Point-To-Point SDLC Station: ❶
*****
Config> set data sdlc 1
Config> n 1
SDLC user configuration
SDLC 1 Config> set link role primary
SDLC 1 Config>list link
list link
Link configuration for: LINK_1 (ENABLED)

Role:          PRIMARY          Type:          POINT-TO-POINT
Duplex:        FULL             Modulo:        8
Idle state:    FLAG             Encoding:       NRZ
Clocking:      INTERNAL         Frame Size:    2048
Speed:         64000            Group Poll:    00
Cable:         RS-232 DCE

Timers:        XID/TEST response: 2.0 sec
```

```

          SNRM response:      2.0 sec
          Poll response:      0.5 sec
          Inter-poll delay:   0.2 sec
          RTS hold delay:     DISABLED
          Inter-frame delay:  DISABLED
          Inactivity timeout: 30.0 sec

Counters: XID/TEST retry:  8
          SNRM retry:       6
          Poll retry:       10

SDLC 1 Config>ex
Config> CTRL p
* restart
Are you sure you want to restart the gateway? (Yes or [No]): yes

* t 6
Config>p appn
APPN user configuration
APPN config>add port sdlc
APPN Port
Interface number(Default 0): [0]? 1
Port name (Max 8 characters) [SDLC001]?
Enable APPN on this port (Y)es (N)o [Y]?
Port Definition
  Service any node: (Y)es (N)o [Y]?
  Edit TG Characteristics: (Y)es (N)o [N]?
  Write this record? [Y]?
  The record has been written.

APPN config>list port sdlc001
PORT:
  Interface number(DLSw = 254): 1
  PORT enable: YES
  Service any node: YES
  Link Type: SDLC
  MAX BTU size: 2048
  MAX number of Link Stations: 1
  Percent of link stations reserved for incoming calls: 0
  Percent of link stations reserved for outgoing calls: 0
  Cost per connect time: 0
  Cost per byte: 0
  Security:(0 = Nonsecure, 1 = Public Switched Network
    2 = Underground Cable, 3 = Secure Conduit,
    4 = Guarded Conduit, 5 = Encrypted, 6 = Guarded Radiation): 0
  Propagation delay:(0 = Minimum, 1 = Lan, 2 = Telephone,
    3 = Packet Switched Network, 4 = Satellite, 5 = Maximum): 2
  Effective capacity: 45
  First user-defined TG characteristic: 128
  Second user-defined TG characteristic: 128
  Third user-defined TG characteristic: 128
APPN config>add link sdlc001
APPN Station
Station name (Max 8 characters) [ ]? TOSECSTN
Activate link automatically (Y)es (N)o [Y]?
Station address(1-fe) [C1]?
Adjacent node type: 0 = APPN network node, 1 = APPN end node
2 = LEN end node, 3 = PU 2.0 node [0]?
Edit Dependent LU Server: (Y)es (N)o [N]?
Allow CP-CP sessions on this link (Y)es (N)o [Y]?
CP-CP session level security (Y)es (N)o [N]?
Configure CP name of adjacent node: (Y)es (N)o [N]?
Edit TG Characteristics: (Y)es (N)o [N]?
Write this record? [Y]?
The record has been written.

APPN config>list link tosecstn
STATION:
  Port name: SDLC001
  Interface number(DLSw = 254): 1
  Link Type: SDLC
  Station address: C1
  Activate link automatically: YES
  Allow CP-CP sessions on this link: YES
  CP-CP session level security: NO
  Fully-qualified CP name of adjacent node:
  Encryption key: 0000000000000000
  Use enhanced session security only: NO
  Cost per connect time: 0
  Cost per byte: 0
  Security:(0 = Nonsecure, 1 = Public Switched Network
    2 = Underground Cable, 3 = Secure Conduit,

```

## APPN

```

    4 = Guarded Conduit, 5 = Encrypted, 6 = Guarded Radiation): 0
Propagation delay:(0 = Minimum, 1 = Lan, 2 = Telephone,
    3 = Packet Switched Network, 4 = Satellite, 5 = Maximum): 2
Effective capacity: 45
First user-defined TG characteristic: 128
Second user-defined TG characteristic: 128
Third user-defined TG characteristic: 128
Predefined TG number: 0
APPN config>act
*****
* Configuring a Secondary Point-To-Point SDLC Station: 2
*****
Config> set data sdlc 1
Config> n 1
SDLC user configuration
SDLC 1 Config> set link role secondary
SDLC 1 Config> set link cable rs-232 dte
SDLC 1 Config>list link      *(will show link configuration)

SDLC 1 Config>add station
Enter station address (in hex) [C1]?
Enter station name [SDLC_C1]?
Include station in group poll list ([Yes] or No): no
Enter max packet size [2048]?
Enter receive window [7]?
Enter transmit window [7]?
SDLC 1 Config>list station all
Address  Name      Status  Max BTU  Rx Window  Tx Window
-----  -
C1      SDLC_C1  ENABLED   2048      7          7
SDLC 1 Config>ex
Config> CTRL p
* restart
Are you sure you want to restart the gateway? (Yes or [No]): yes

* t 6
Config>p appn
APPN user configuration
APPN config>add port sdlc
APPN Port
Interface number(Default 0): [0]? 1
Port name (Max 8 characters) [SDLC001]?
Enable APPN on this port (Y)es (N)o [Y]?
Port Definition
  Service any node: (Y)es (N)o [Y]?
  Edit TG Characteristics: (Y)es (N)o [N]?
  Write this record? [Y]?
  The record has been written.
APPN config>list port sdlc001  *(will show port definitions)
APPN config>add link sdlc001
APPN Station
Station name (Max 8 characters) [ ]? TOPRISTN
  Activate link automatically (Y)es (N)o [Y]?
  (Note: "Y" to accept activation from the primary or negotiable station)
  Station address(1-fe) [C1]?
  Adjacent node type: 0 = APPN network node, 1 = APPN end node
  2 = LEN end node, 3 = PU 2.0 node [0]?
  Edit Dependent LU Server: (Y)es (N)o [N]?
  Allow CP-CP sessions on this link (Y)es (N)o [Y]?
  CP-CP session level security (Y)es (N)o [N]?
  Configure CP name of adjacent node: (Y)es (N)o [N]?
  Edit TG Characteristics: (Y)es (N)o [N]?
  Write this record? [Y]?
  The record has been written.
APPN config>list link topristn *(will show link station definitions)
APPN config>act
*****
* Configuring a Negotiable Point-To-Point SDLC Station: 3
*****
Config> set data sdlc 1
Config> n 1
SDLC user configuration
SDLC 1 Config> set link role negotiable
SDLC 1 Config>list link      *(will show link configuration)
SDLC 1 Config>ex
Config> CTRL p
* restart
Are you sure you want to restart the gateway? (Yes or [No]): yes

* t 6

```

```

Config>p appn
APPN user configuration
APPN config>add port sdlc
APPN Port
Interface number(Default 0): [0]? 1
Port name (Max 8 characters) [SDLC001]?
Enable APPN on this port (Y)es (N)o [Y]?
Port Definition
  Service any node: (Y)es (N)o [Y]?
Edit TG Characteristics: (Y)es (N)o [N]?
Write this record? [Y]?
The record has been written.
APPN config>list port sdlc001          **(will show port definitions)
APPN config>add link sdlc001
APPN Station
Station name (Max 8 characters) [ ]? TOREMSTN
Activate link automatically (Y)es (N)o [Y]?
Station address(1-fe) [C1]?
  (Note: C1 may be used if this station is becoming a secondary station)
Adjacent node type: 0 = APPN network node, 1 = APPN end node
2 = LEN end node, 3 = PU 2.0 node [0]?
Edit Dependent LU Server: (Y)es (N)o [N]?
Allow CP-CP sessions on this link (Y)es (N)o [Y]?
CP-CP session level security (Y)es (N)o [N]?
Configure CP name of adjacent node: (Y)es (N)o [N]?
Edit TG Characteristics: (Y)es (N)o [N]?
Write this record? [Y]?
The record has been written.

APPN config>list link toremstn        **(will show link station definitions)
APPN config>act
*****
* Configuring a Primary Multipoint SDLC Station: 4
*****
Config> set data sdlc 1
Config> n 1
SDLC user configuration
SDLC 1 Config> set link role primary
SDLC 1 Config> set link type multipoint
SDLC 1 Config>list link                **(will show link configuration)
SDLC 1 Config>ex
Config> CTRL p
* reload
Are you sure you want to reload the gateway? (Yes or [No]): yes
* t 6
Config>p appn
APPN user configuration
APPN config>add port sdlc
APPN Port
Interface number(Default 0): [0]? 1
Port name (Max 8 characters) [SDLC001]?
Enable APPN on this port (Y)es (N)o [Y]?
Port Definition
  Service any node: (Y)es (N)o [Y]?
  Maximum number of link stations (1-127) ? 2
Edit TG Characteristics: (Y)es (N)o [N]?
Write this record? [Y]?
The record has been written.
APPN config>list port sdlc001          **(will show port definitions)
APPN config>add link sdlc001
APPN Station
Station name (Max 8 characters) [ ]? TOSTNC1
Activate link automatically (Y)es (N)o [Y]?
Station address(1-fe) [C1]?
  (Note: C1 must match to the remote secondary station)
Adjacent node type: 0 = APPN network node, 1 = APPN end node
2 = LEN end node, 3 = PU 2.0 node [0]?
Edit Dependent LU Server: (Y)es (N)o [N]?
Allow CP-CP sessions on this link (Y)es (N)o [Y]?
CP-CP session level security (Y)es (N)o [N]?
Configure CP name of adjacent node: (Y)es (N)o [N]?
Edit TG Characteristics: (Y)es (N)o [N]?
Write this record? [Y]?
The record has been written.

APPN config>list link tostnc1          **(will show link station definitions)
APPN config>add link sdlc001
APPN Station
Station name (Max 8 characters) [ ]? TOSTNC2
Activate link automatically (Y)es (N)o [Y]?
Station address(1-fe) [C2]?

```

## APPN

```
(Note: C2 must match to the remote secondary station)
Adjacent node type: 0 = APPN network node, 1 = APPN end node
2 = LEN end node, 3 = PU 2.0 node [0]?
Edit Dependent LU Server: (Y)es (N)o [N]?
Allow CP-CP sessions on this link (Y)es (N)o [Y]?
CP-CP session level security (Y)es (N)o [N]?
Configure CP name of adjacent node: (Y)es (N)o [N]?
Edit TG Characteristics: (Y)es (N)o [N]?
Write this record? [Y]?
The record has been written.
APPN config>list link tostnc2      **(will show link station definitions)
APPN config>act

*****
* Configuring a Secondary point-to-point (Multi APPN link station): 5
*****
Config> set data sdlc 1
Config> n 1
SDLC user configuration
SDLC 1 Config> set link role secondary
SDLC 1 Config> set link type point-to-point
SDLC 1 Config>list link          **(will show link configuration)
SDLC 1 Config>ex
Config> CTRL p
* reload
Are you sure you want to reload the gateway? (Yes or [No]): yes
* t 6
Config>p appn
APPN user configuration
APPN config>add port sdlc
APPN Port
Interface number(Default 0): [0]? 1
Port name (Max 8 characters) [SDLC001]?
Enable APPN on this port (Y)es (N)o [Y]?
Port Definition
Service any node: (Y)es (N)o [Y]?
Maximum number of link stations (1-127) ? 2
Edit TG Characteristics: (Y)es (N)o [N]?
Write this record? [Y]?
The record has been written.
APPN config>list port sdlc001      **(will show port definitions)
APPN config>add link sdlc001
APPN Station
Station name (Max 8 characters) [ ]? TOSTNC1
Activate link automatically (Y)es (N)o [Y]?
Station address(1-fe) [C1]?
(Note: C1 must match to the remote secondary station)
Adjacent node type: 0 = APPN network node, 1 = APPN end node
2 = LEN end node, 3 = PU 2.0 node [0]?
Edit Dependent LU Server: (Y)es (N)o [N]?
Allow CP-CP sessions on this link (Y)es (N)o [Y]?
CP-CP session level security (Y)es (N)o [N]?
Configure CP name of adjacent node: (Y)es (N)o [N]?
Edit TG Characteristics: (Y)es (N)o [N]?
Write this record? [Y]?
The record has been written.
APPN config>list link tostnc1      **(will show link station definitions)
APPN config>add link sdlc001
APPN Station
Station name (Max 8 characters) [ ]? TOSTNC2
Activate link automatically (Y)es (N)o [Y]?
Station address(1-fe) [C2]?
(Note: C2 must match to the remote secondary station)
Adjacent node type: 0 = APPN network node, 1 = APPN end node
2 = LEN end node, 3 = PU 2.0 node [0]?
Edit Dependent LU Server: (Y)es (N)o [N]?
Allow CP-CP sessions on this link (Y)es (N)o [Y]?
CP-CP session level security (Y)es (N)o [N]?
Configure CP name of adjacent node: (Y)es (N)o [N]?
Edit TG Characteristics: (Y)es (N)o [N]?
Write this record? [Y]?
```



```
The record has been written.
APPN config>list link tostnc2    **(will show link station definitions)
APPN config>act
```

**Note:**

- 1 Configuring a primary point-to-point SDLC station
- 2 Configuring a secondary point-to-point SDLC station
- 3 Configuring a negotiable point-to-point SDLC station
- 4 Configuring a primary multipoint SDLC station
- 5 Configuring secondary point-to-point (multi APPN link stations)

## Configuring APPN Over X.25

This example shows APPN configuration for an X.25 port and two link stations. One link station is a PVC and one is an SVC. The SVC is configured as a limited resource. The SVC will be activated when needed and brought down when it is not.

```
Boats Config>p appn
APPN user configuration
Boats APPN config>add port
APPN Port
Link Type: (P)PP, (F)RAME RELAY, (E)THERNET, (T)OKEN RING,
(M)PC, (S)DLC, (X)25, (FD)DI, (D)LSw, (A)TM, (IP)[ ]? x
Interface number(Default 0):[0]? 2
Port name (Max 8 characters)[X25002]?
Enable APPN on this port (Y)es (N)o[Y]?
Port Definition
    Service any node: (Y)es (N)o[Y]?
    Maximum number of link stations (1-239)[239]?
    Percent of link stations reserved for incoming calls (0-100)[0]?
    Percent of link stations reserved for outgoing calls (0-100)[0]?
Edit TG Characteristics: (Y)es (N)o[N]?
Write this record?[Y]?
The record has been written.

Boats APPN config>add link
APPN Station
Port name for the link station[ ]? x25002
Station name (Max 8 characters)[ ]? x25svc1
    Limited resource: (Y)es (N)o[N]? Y
    Activate link automatically (Y)es (N)o[N]?
    Link Type (0 = PVC , 1 = SVC)[0]? 1
    DTE Address [0]? 2222
    Adjacent node type: 0 = APPN network node,
    1 = APPN end node or Unknown node type
    2 = LEN end node, 3 = PU 2.0 node[1]?
Edit Dependent LU Server: (Y)es (N)o[N]?
    Allow CP-CP sessions on this link (Y)es (N)o[Y]? N
    CP-CP session level security (Y)es (N)o[N]?
    Configure CP name of adjacent node: (Y)es (N)o[N]?
Edit TG Characteristics: (Y)es (N)o[N]?
Write this record?[Y]?
The record has been written.

Boats APPN config>add link
APPN Station
Port name for the link station[ ]? x25002
Station name (Max 8 characters)[ ]? x25pvc1
    Limited resource: (Y)es (N)o[N]?
    Activate link automatically (Y)es (N)o[Y]?
    Link Type (0 = PVC , 1 = SVC)[0]?
    Logical channel number (1-4095)[1]?
    Adjacent node type: 0 = APPN network node,
    1 = APPN end node or Unknown node type
    2 = LEN end node, 3 = PU 2.0 node[1]?
Edit Dependent LU Server: (Y)es (N)o[N]?
    Allow CP-CP sessions on this link (Y)es (N)o[Y]?
    CP-CP session level security (Y)es (N)o[N]?
    Configure CP name of adjacent node: (Y)es (N)o[N]?
Edit TG Characteristics: (Y)es (N)o[N]?
Write this record?[Y]?
The record has been written.
```

## APPN

```
Boats APPN config>list port x25002
PORT:
  Interface number(DLSw = 254): 2
  PORT enable: YES
  Service any node: YES
  Link Type: X25
  MAX BTU size: 2048
  MAX number of Link Stations: 239
  Percent of link stations reserved for incoming calls: 0
  Percent of link stations reserved for outgoing calls: 0
  Cost per connect time: 0
  Cost per byte: 0
  Security:(0 = Nonsecure, 1 = Public Switched Network
    2 = Underground Cable, 3 = Secure Conduit,
    4 = Guarded Conduit, 5 = Encrypted, 6 = Guarded Radiation): 0
  Propagation delay:(0 = Minimum, 1 = Lan, 2 = Telephone,
    3 = Packet Switched Network, 4 = Satellite, 5 = Maximum): 3
  Effective capacity: 45
  First user-defined TG characteristic: 128
  Second user-defined TG characteristic: 128
  Third user-defined TG characteristic: 128
Boats APPN config>list link x25svc1
STATION:
  Port name: X25002
  Interface number(DLSw = 254): 2
  Link Type: X25
  Link Type (0 = PVC , 1 = SVC): 1
  DTE Address: 2222
  Activate link automatically: YES
  Allow CP-CP sessions on this link: YES
  CP-CP session level security: NO
  Fully-qualified CP name of adjacent node:
  Encryption key: 0000000000000000
  Use enhanced session security only: NO
  Cost per connect time: 0
  Cost per byte: 0
  Security:(0 = Nonsecure, 1 = Public Switched Network
    2 = Underground Cable, 3 = Secure Conduit,
    4 = Guarded Conduit, 5 = Encrypted, 6 = Guarded Radiation): 0
  Propagation delay:(0 = Minimum, 1 = Lan, 2 = Telephone,
    3 = Packet Switched Network, 4 = Satellite, 5 = Maximum): 3
  Effective capacity: 45
  First user-defined TG characteristic: 128
  Second user-defined TG characteristic: 128
  Third user-defined TG characteristic: 128
  Predefined TG number: 0
Boats APPN config>list link x25pvc1
STATION:
  Port name: X25002
  Interface number(DLSw = 254): 2
  Link Type: X25
  Link Type (0 = PVC , 1 = SVC): 0
  Logical Channel number: 1
  Activate link automatically: YES
  Allow CP-CP sessions on this link: YES
  CP-CP session level security: NO
  Fully-qualified CP name of adjacent node:
  Encryption key: 0000000000000000
  Use enhanced session security only: NO
  Cost per connect time: 0
  Cost per byte: 0
  Security:(0 = Nonsecure, 1 = Public Switched Network
    2 = Underground Cable, 3 = Secure Conduit,
    4 = Guarded Conduit, 5 = Encrypted, 6 = Guarded Radiation): 0
  Propagation delay:(0 = Minimum, 1 = Lan, 2 = Telephone,
    3 = Packet Switched Network, 4 = Satellite, 5 = Maximum): 3
  Effective capacity: 45
  First user-defined TG characteristic: 128
  Second user-defined TG characteristic: 128
  Third user-defined TG characteristic: 128
  Predefined TG number: 0
Boats APPN config>li all
NODE:
  NETWORK ID: STFNET
  CONTROL POINT NAME: BOATS
  XID: 00000
  APPN ENABLED: YES
  MAX SHARED MEMORY: 4096
  MAX CACHED: 4000
```

```

DLUR:
      DLUR ENABLED: NO
      PRIMARY DLUS NAME:
CONNECTION NETWORK:
      CN NAME          LINK TYPE  PORT INTERFACES
-----
COS:
      COS NAME
      -----
      BATCH
      BATCHSC
      CONNECT
      INTER
      INTERSC
      CPSVCMG
      SNASVCMG
      MODE NAME  COS NAME
      -----
PORT:
      INTF   PORT   LINK   HPR   SERVICE  PORT
      NUMBER NAME   TYPE   ENABLED ANY   ENABLED
      -----
           2   X25002   X25    NO    YES     YES
           5   TR005   IBMTRNET YES   YES     YES
STATION:
      STATION  PORT   DESTINATION  HPR   ALLOW  ADJ NODE
      NAME     NAME   ADDRESS      ENABLED CP-CP  TYPE
      -----
      X25SVC1  X25002   2222        NO    NO     1
      X25PVC1  X25002   1           NO    YES    1
LU NAME:
      LU NAME          STATION NAME          CP NAME
      -----

```

Boats APPN config>ex

```

Boats Config>n 2
X.25 User Configuration
Boats X.25 Config>li all

```

X.25 Configuration Summary

```

Node Address:      1111
Max Calls Out:    4
Inter-Frame Delay: 0      Encoding: NRZ
Speed:            64000    Clocking: External
MTU:              2048     Cable:      V.35 DTE
Lower DTR:        Disabled
Default Window:   2        SVC idle:   30 seconds
National Personality: GTE Telenet (DCE)
PVC               low: 1   high: 4
Inbound           low: 0   high: 0
Two-Way           low: 10  high: 20
Outbound          low: 0   high: 0
Throughput Class in bps Inbound: 2400
Throughput Class in bps Outbound: 2400

```

X.25 National Personality Configuration

```

Follow CCITT: on      OSI 1984: on      OSI 1988: off
Request Reverse Charges: off  Accept Reverse Charges: off
Frame Extended seq mode: off  Packet Extended seq mode: off
Incoming Calls Barred: off    Outgoing Calls Barred: off
Throughput Negotiation: off   Flow Control Negotiation: off
Suppress Calling Addresses: off
DDN Address Translation: off
Call Request Timer: 20 decaseconds
Clear Request Timer: 18 decaseconds (1 retries)
Reset Request Timer: 18 decaseconds (1 retries)
Restart Request Timer: 18 decaseconds (1 retries)
Min Recall Timer: 10 seconds
Min Connect Timer: 90 seconds
Collision Timer: 10 seconds
T1 Timer: 4.00 seconds      N2 timeouts: 20
T2 Timer: 0.00 seconds      DP Timer: 500 milliseconds
Standard Version: 2        Network Type: CCITT
Disconnect Procedure: passive
Window Size      Frame: 7      Packet: 2
Packet Size      Default: 128  Maximum: 256

```

## APPN

### X.25 protocol configuration

Prot Number	Window Size	Packet-size Default	Packet-size Maximum	Idle Time	Max VCs	Station Type
30 -> APPN	7	128	1024	0	4	PEER

### X.25 PVC configuration

Prtcl	X.25_address	Active Enc	Window	Pkt_len	Pkt_chan
30 (APPN)	6666	NONE	2	128	1

### X.25 address translation configuration

IF #	Prot #	Active Enc	Protocol	-> X.25 address
2	30 (APPN)	NONE	appn	-> 6666

Boats X.25 Config>

## Configuring APPN Over Frame Relay

The following example shows configuration of APPN over Frame Relay.

```
nada207 Config>p appn
APPN user configuration
nada207 APPN config>add port
APPN Port
Link Type: (P)PP, (F)RAME RELAY, (E)THERNET, (T)OKEN RING,
(M)PC, (S)DLC, (X)25, (FD)DI, (D)LSw, (A)TM, (IP) [ ] ?f
Interface number(Default 0): [0]? 4
Port name (Max 8 characters) [FR004]?
Enable APPN on this port (Y)es (N)o [Y]?
Port Definition
  Service any node: (Y)es (N)o [Y]?
  High performance routing: (Y)es (N)o [Y]?
  Maximum BTU size (768-2048) [2048]?
  Maximum number of link stations (1-976) [512]?
  Percent of link stations reserved for incoming calls (0-100) [0]?
  Percent of link stations reserved for outgoing calls (0-100) [0]?
  Local SAP address (04-EC) [4]?
  Support bridged formatted frames: (Y)es (N)o [N]?
Edit TG Characteristics: (Y)es (N)o [N]?
Edit LLC Characteristics: (Y)es (N)o [N]?
Edit HPR defaults: (Y)es (N)o [N]?
Write this record? [Y]?
The record has been written.
nada207 APPN config>add link
APPN Station
Port name for the link station [ ]? fr004
Station name (Max 8 characters) [ ]? tonn
  Activate link automatically (Y)es (N)o [Y]?
  DLCI number for link (16-1007) [16]?
  Adjacent node type: 0 = APPN network node,
  1 = APPN end node or Unknown node type
  2 = LEN end node, 3 = PU 2.0 node [1]? 0
  High performance routing: (Y)es (N)o [Y]?
Edit Dependent LU Server: (Y)es (N)o [N]?
  Allow CP-CP sessions on this link (Y)es (N)o [Y]?
  CP-CP session level security (Y)es (N)o [N]?
  Configure CP name of adjacent node: (Y)es (N)o [N]?
Edit TG Characteristics: (Y)es (N)o [N]?
Edit LLC Characteristics: (Y)es (N)o [N]?
Edit HPR defaults: (Y)es (N)o [N]?
Write this record? [Y]?
The record has been written.
nada207 APPN config>act
nada207 APPN config>exit
nada207 Config>write
Config Save: Using bank B and config number 2
```

## Configuring APPN Over Frame Relay BAN

The following example shows configuration of APPN over Frame Relay BAN.

```

nada207 Config>p appn
APPN user configuration
nada207 APPN config>add port
APPN Port
Link Type: (P)PP, (F)RAME RELAY, (E)THERNET, (T)OKEN RING,
(M)PC, (S)DLC, (X)25, (FD)DI, (D)LSw, (A)TM, (IP) [ ] ?f
Interface number(Default 0): [0]? 4
Port name (Max 8 characters) [FR004]?
Enable APPN on this port (Y)es (N)o [Y]?
Port Definition
  Service any node: (Y)es (N)o [Y]?
  High performance routing: (Y)es (N)o [Y]?
  Maximum BTU size (768-2048) [2048]?
  Maximum number of link stations (1-976) [512]?
  Percent of link stations reserved for incoming calls (0-100) [0]?
  Percent of link stations reserved for outgoing calls (0-100) [0]?
  Local SAP address (04-EC) [4]?
  Support bridged formatted frames: (Y)es (N)o [N]? y
  Boundary node identifier (hex-noncanonical) [4FFF00000000]?
41235fad
  Local HPR SAP address (04-EC) [C8]?
Edit TG Characteristics: (Y)es (N)o [N]?
Edit LLC Characteristics: (Y)es (N)o [N]?
Edit HPR defaults: (Y)es (N)o [N]?
Write this record? [Y]?
The record has been written.
nada207 APPN config> add link
APPN Station
Port name for the link station [ ]? fr004
Station name (Max 8 characters) [ ]? tonn
  Activate link automatically (Y)es (N)o [Y]?
  DLCI number for link (16-1007) [16]?
  Support bridged formatted frames: (Y)es (N)o [N]? y
  MAC address of adjacent node (hex-noncanonical) [000000000000]? 3456
  Adjacent node type: 0 = APPN network node,
  1 = APPN end node or Unknown node type
  2 = LEN end node, 3 = PU 2.0 node [1]? 0
  High performance routing: (Y)es (N)o [Y]?
Edit Dependent LU Server: (Y)es (N)o [N]?
  Allow CP-CP sessions on this link (Y)es (N)o [Y]?
  CP-CP session level security (Y)es (N)o [N]?
  Configure CP name of adjacent node: (Y)es (N)o [N]?
Edit TG Characteristics: (Y)es (N)o [N]?
Edit LLC Characteristics: (Y)es (N)o [N]?
Edit HPR defaults: (Y)es (N)o [N]?
Write this record? [Y]?
The record has been written.
nada207 APPN config>act
nada207 APPN config>exit
nada207 Config>write
Config Save: Using bank B and config number 2

```

## Configuring TN3270E Using DLUR

```

APPN config>
APPN config>set node
Enable APPN (Y)es (N)o [Y]?
Network ID (Max 8 characters) [STFNET]?
Control point name (Max 8 characters) [VLNN2]?
Enable branch extender (Y)es (N)o [N]?
Route addition resistance(0-255) [128]?
XID ID number for subarea connection (5 hex digits) [00000]?
Use enhanced #BATCH COS (Y)es (N)o [Y]?
Use enhanced #BATCHSC COS (Y)es (N)o [Y]?
Use enhanced #INTER COS (Y)es (N)o [Y]?
Use enhanced #INTERSC COS (Y)es (N)o [Y]?
Write this record? [Y]?
The record has been written.
APPN config>
APPN config>
APPN config>set dlur
Enable DLUR (Y)es (N)o [Y]?
Fully-qualified CP name of primary DLUS [STFNET.MVS8]?

```

## APPN

```
Fully-qualified CP name of backup DLUS []?
Perform retries to restore disrupted pipe [Y]?
Delay before initiating retries(0-2756000 seconds) [120]?
Perform short retries to restore disrupted pipe [Y]?
Short retry timer(0-2756000 seconds)[120]?
Short retry count(0-65535) [5]?
Perform long retry to restore disrupted pipe [Y]?
Long retry timer(0-2756000 seconds) [300]?
Write this record? [Y]?
The record has been written.
APPN config>
APPN config>tn3270e
TN3270E config>set
TN3270E Server Parameters
  Enable TN3270E Server (Y/N) [Y]?
  TN3270E Server IP Address[4.3.2.1]?
  Port Number[23]?
  Enable Client IP Address to LU Name Mapping (Y/N) [N]
  Default Pool Name[PUBLIC]?
  NetDisp Advisor Port Number[10008]?
  Keepalive type:
    0 = none,
    1 = Timing Mark,
    2 = NOP[2]?
  Frequency ( 1 - 65535 seconds) [60]?
  Automatic Logoff (Y/N) [N]?
Write this record?[Y]?
The record has been written.
TN3270E config>exit
APPN config>
APPN config>add loc
Local PU information
  Station name (Max 8 characters) []? link1
  Fully-qualified CP name of primary DLUS[STFNET.MVS8] ?
  Fully-qualified CP name of a backup DLUS[]?
  Local Node ID (5 hex digits)[11111]?
  Autoactivate (y/n) [Y]?
Write this record?[Y]?
The record has been written.

APPN config>tn3270
TN3270E config>add im
TN3270E Server Implicit definitions
  Pool name (Max 8 characters) [<DEFLT>]?
  Station name (Max 8 characters) []? link1
  LU Name Mask (Max 5 characters) [@01LU]?
  LU Type      ( 1 - 3270 mod 2 display
                2 - 3270 mod 3 display
                3 - 3270 mod 4 display
                4 - 3270 mod 5 display) [1]?
  Specify LU Address Range(s) (y/n) [n]
  Number of Implicit LUs in Pool(1-253) [50]?
Write this record?[Y]?
The record has been written.
TN3270E config>
TN3270E config>add lu
TN3270E Server LU Definitions
  LU name(Max 8 characters) []? printer1
  NAU Address (2-254) [0] 2
  Station name (Max 8 characters) []? link1
  Class:
    1 = Explicit Workstation,
    2 = Implicit Workstation,
    3 = Explicit Printer,
    4 = Implicit Printer[3]?
  LU Type ( 5 - 3270 printer
            6 - SCS printer) [5]?
```

```

Write this record[Y]?
The record has been written.
TN3270E config>
TN3270E config>list all
TN3270E Server Definitions
TN3270E enabled: YES
TN3270E IP Address: 4.3.2.1
TN3270E Port Number: 23
Keepalive type: NOP           Frequency: 60
Automatic Logoff: N          Timeout: 30
    Enable IP Precedence: N
Link Station: link1
    Local Node ID: 11111
    Auto activate : YES
    Implicit Pool Information
        Number of LUs: 50
        LU Mask: @01LU
    LU Name   NAU addr   Class           Assoc LU Name   Assoc   NAU addr
-----
    printer1   2       Explicit Printer

TN3270E config>exit
APPN Config>exit

Config>
Config>p ip
Internet protocol user configuration
IP config>li all
Interface addresses
IP addresses for each interface:
    intf 0   9.1.1.20       255.0.0.0       Local wire broadcast, fill 1
    intf 1
    intf 2
IP disabled on this interface
IP disabled on this interface
Internal IP address: 4.3.2.1

Routing

Protocols
BOOTP forwarding: disabled
IP Time-to-live: 64
Source Routing: enabled
Echo Reply: enabled
TFTP Server: enabled
Directed broadcasts: enabled
ARP subnet routing: disabled
ARP network routing: disabled
Per-packet-multipath: disabled
OSPF: disabled
BGP: disabled
RIP: disabled

IP config>
*
```

## Configuring TN3270E Using a Subarea Connection

```

Config>p appn
APPN config>add port
APPN Port
Link Type: (P)PP, (FR)AME RELAY, (E)THERNET, (T)OKEN RING,
(S)DLC, (X)25, (FD)DI, (D)LSw, (A)TM, (I)P []?fr
Interface number(Default 0): [0]? 2
Port name (Max 8 characters) [F00002]?
```

## APPN

```
Enable APPN on this port (Y)es (N)o [Y]?
Port Definition
  Support multiple subarea (Y)es (N)o [N]? y
All active port names will be of the form <port name sap>
  Service any node: (Y)es (N)o [Y]?
  High performance routing: (Y)es (N)o [Y]? n
  Maximum BTU size (768-8136) [2048]?
  Maximum number of link stations (1-976) [512]?
  Percent of link stations reserved for incoming calls (0-100) [0]?
  Percent of link stations reserved for outgoing calls (0-100) [0]?
  Local SAP address (04-EC) [4]?
  Support bridged formatted frames: (Y)es (N)o [N]?
Edit TG Characteristics: (Y)es (N)o [N]?
Edit LLC Characteristics: (Y)es (N)o [N]?
Edit HPR defaults: (Y)es (N)o [N]?
Write this record? [Y]?
The record has been written.
APPN config>add link
APPN Station
Port name for the link station [ ]=? f00002
Station name (Max 8 characters) [ ]? suba1
  Activate link automatically (Y)es (N)o [Y]?
  DLCI number for link (16-1007) [16]? 23
  Adjacent node type: 0 = APPN network node,
  1 = APPN end node or Unknown node type,
  2 = LEN end node [0]?
  Solicit SSCP Session: (Y)es (N)o [N]? y
    Local Node ID (5 hex digits) [000000]? 12345
  Local SAP address (04-EC) [4]? c
  Allow CP-CP sessions on this link (Y)es (N)o [Y]? n
  Configure CP name of adjacent node: (Y)es (N)o [N]?
Edit TG Characteristics: (Y)es (N)o [N]?
Edit LLC Characteristics: (Y)es (N)o [N]?
Edit HPR defaults: (Y)es (N)o [N]?
Write this record? [Y]?
The record has been written.
APPN config>act

APPN config>
APPN config>set node
Enable APPN (Y)es (N)o [Y]?
Network ID (Max 8 characters) [STFNET]?
Control point name (Max 8 characters) [VLNN2]?
Enable branch extender (Y)es (N)o [N]?
Route addition resistance(0-255) [128]?
XID ID number for subarea connection (5 hex digits) [000000]?
Use enhanced #BATCH COS (Y)es (N)o [Y]?
Use enhanced #BATCHSC COS (Y)es (N)o [Y]?
Use enhanced #INTER COS (Y)es (N)o [Y]?
Use enhanced #INTERSC COS (Y)es (N)o [Y]?
Write this record? [Y]?
The record has been written.
APPN config>

APPN config>
APPN config>tn3270e
TN3270E config>set
TN3270E Server Parameters
  Enable TN3270E Server (Y/N) [Y]?
  TN3270E Server IP Address[4.3.2.1]?
  Port Number[23]?
  Enable Client IP Address to LU Name Mapping (Y/N) [N]
  Default Pool Name[PUBLIC]?
  NetDisp Advisor Port Number[10008]?
  Keepalive type:
    0 = none,
    1 = Timing Mark,
```



```

    2 = NOP[2]?
    Frequency ( 1 - 65535 seconds) [60]?
    Automatic Logoff (Y/N) [N]?
Write this record? [Y]?
The record has been written.
TN3270E config>exit
APPN config>
Write this record? [Y]?
The record has been written.

APPN config>tn3270
TN3270E config>add im
TN3270E Server Implicit definitions
    Pool name (Max 8 characters) [<DEFLT>]?
    Station name (Max 8 characters) []? suba1
    LU Name Mask (Max 5 characters) [@01LU]?
    Specify LU Address Range(s) (y/n) [N]
    Number of Implicit LUs in Pool(1-253) [50]?
Write this record? [Y]?
The record has been written.
TN3270E config>
TN3270E config>add lu
TN3270E Server LU Definitions
    LU name(Max 8 characters) []? printer1
    NAU Address (2-254) [2]
    Station name (Max 8 characters) []? suba1
    Class:
        1 = Explicit Workstation,
        2 = Implicit Workstation,
        3 = Explicit Printer,
        4 = Implicit Printer[3]?
    LU Type ( 5 - 3270 printer
        6 - SCS printer) [5]?
Write this record[Y]?
The record has been written.
TN3270E config>
TN3270E config>list all
TN3270E Server Definitions
TN3270E enabled: YES
TN3270E IP Address: 4.3.2.1
TN3270E Port Number: 23
Keepalive type: NOP           Frequency: 60
Automatic Logoff: N           Timeout: 30
    Enable IP Precedence: N
Link Station: suba1
    Local Node ID: 12345
    Auto activate : YES
    Implicit Pool Informationø
        Number of LUs: 50
        LU Mask: @01LU
    LU Name   NAU addr   Class           Assoc LU Name   Assoc   NAU addr
-----
    printer1   2           Explicit Printer

```

```

TN3270E config>exit
APPN Config>exit

```

```

APPN config>act

```

## Configuring Enterprise Extender Support for HPR Over IP

```

t 6
Q45 Config>p appn
APPN config>add port

```

## APPN

```
APPN Port
Link Type: (P)PP, (FR)AME RELAY, (E)THERNET, (T)OKEN RING,
(S)DLC, (X)25, (FD)DI, (D)LSw, (A)TM, (I)P [ ]? ip
Port name (Max 8 characters) [IP255]?
Enable APPN on this port (Y)es (N)o [Y]?
Port Definition
Service any node: (Y)es (N)o [Y]?
Maximum BTU size (768-2048) [768]?
UDP port number for XID exchange (1024-65535) [11000]?
UDP port number for low priority traffic (1024-65535) [11004]?
UDP port number for medium priority traffic (1024-65535) [11003]?
UDP port number for high priority traffic (1024-65535) [11002]?
UDP port number for network priority traffic (1024-65535) [11001]?
IP Network Type: 0 = CAMPUS, 1 = WIDEAREA [0]?
Local SAP address (04-EC) [4]?
LDLC Retry Count(1-255) [3]?
LDLC Timer Period(1-255 seconds) [15]?
Edit TG Characteristics: (Y)es (N)o [N]?
Write this record? [Y]?
The record has been written.
****3.3.3.3 is the router's internal IP address
APPN config>add link
APPN Station
Port name for the link station [ ]? ip255
Station name (Max 8 characters) [ ]? tonn
Activate link automatically (Y)es (N)o [Y]?
IP address of adjacent node [0.0.0.0]? 3.3.3.3
Adjacent node type: 0 = APPN network node,
1 = APPN end node or Unknown node type [0]?
Allow CP-CP sessions on this link (Y)es (N)o [Y]?
CP-CP session level security (Y)es (N)o [N]?
Configure CP name of adjacent node: (Y)es (N)o [N]?
Remote SAP(04-EC) [4]?
IP Network Type: 0 = CAMPUS, 1 = WIDEAREA [0]?
LDLC Retry Count(1-255) [3]?
LDLC Timer Period(1-255 seconds) [15]?
Edit TG Characteristics: (Y)es (N)o [N]?
Write this record? [Y]?
The record has been written.
APPN config>
```

## Configuring Connection Networks over HPR over IP

```
t 6
Config>p appn
APPN config>add connection network
Fully-qualified connection network name (netID.CNname) [ ]? supernet.cn1
Port Type: (E)thernet, (T)okenRing, (FR), (A)TM, (FD)DI, (I)P [ ]? ip
Limited resource timer for HPR (1-2160000 seconds) [180]?
Edit TG Characteristics: (Y)es (N)o [N]?
Write this record? [Y]?
The record has been written.
APPN config>add additional port
APPN Connection Networks Port Interface
Fully-qualified connection network name (CPname.CNname) [ ]? supernet.cn1
Port name [ ]? "en000"
Write this record? [Y]?
The record has been written.
```

## Configuring an Extended Border Node

```
Spurs APPN config>p app
Spurs APPN config>set node
Enable APPN (Y)es (N)o [N]? y
Network ID (Max 8 characters) [STFDDD3]?
```

```

Control point name (Max 8 characters) [SPURS]?
Enable branch extender or extended border node
(0=Neither, 1=Branch Extender, 2=Border Node)[2]?
Subnet visit count(1-255) [3]?
Cache searches for (0-255) minutes [8]?
Maximum number of searches to cache (0(unlimited)-32765) [0]?
Dynamic routing list updates (0=None, 1=Full, 2=Limited) [1]?
Enable routing list optimization (Y)es (N)o [Y]?
Route addition resistance(0-255) [128]?
XID ID number for subarea connection (5 hex digits) [000000]?
Use enhanced #BATCH COS (Y)es (N)o [Y]?
Use enhanced #BATCHSC COS (Y)es (N)o [Y]?
Use enhanced #INTER COS (Y)es (N)o [Y]?
Use enhanced #INTERSC COS (Y)es (N)o [Y]?
Write this record? [Y]?
The record has been written.
Spurs APPN config>act
APPN is not currently active
Spurs APPN config>add rout
Routing list name []? list1
Subnet visit count (1-255) [3]?
Dynamic routing list updates (0=None, 1=Full, 2=Limited) [1]?
Enable routing list optimization (Y)es (N)o [Y]?
Destination LUs found via this list:
  (netID.LUname)[] ? net1*
  (netID.LUname) []?
Routing CPs (with optional subnet visit count):
  (netID.CPname ?) [ 3]? net2.router2
  (netID.CPname ?) [ 3]?
Write this record? (Y)es (N)o [Y]?
The record has been written.

```

```

Spurs APPN config>add cos
COS mapping table name []? cos1
Non-native network (netID.CPname) []? net2.router2
Non-native network (netID.CPname) []?
Native and non-native COS name pair [ ]? #inter
Native and non-native COS name pair [ ]?
Write this record? (Y)es (N)o [Y]?
The record has been written.

```

**APPN**

## Chapter 2. Configuring and Monitoring APPN

This chapter describes the APPN configuration and monitoring commands. It includes the following sections:

- “APPN Configuration Command Summary”
- “APPN Configuration Command Detail” on page 81

---

### Accessing the APPN Configuration Process

Use the following procedure to access the APPN *configuration* process.

1. At the \* prompt, enter **talk 6**. The Config> prompt is displayed.  
(If this prompt is not displayed, press **Return** again.)
2. Enter **protocol appn**. The APPN Config> prompt is displayed.
3. Enter an APPN configuration command.

---

### APPN Configuration Command Summary

Table 3. APPN Configuration Command Summary

Command	Function	See page:
? (Help)	Displays all the commands available for this command level or lists the options for specific commands (if available). See “Getting Help” on page xxvi.	
Enable/Disable	Enables/disables the following: APPN Dependent LU Requestor Port <i>port name</i>	81
Set	Sets the following: Node Traces HPR DLUR Management Tuning	81 99 86 90 118 94
Add	Adds or updates the following: Port <i>port name</i> Link-station <i>link station name</i> LU-Name <i>LU name</i> Connection-network <i>connection network name</i> Additional-port-to-connection-network Mode Focal_point local-pu Routing_list COS_mapping_table	122 140 158 159 166 164 167 167 169 172

## APPN Configuration Commands (Talk 6)

Table 3. APPN Configuration Command Summary (continued)

Command	Function	See page:
Delete	Deletes the following: <ul style="list-style-type: none"> <li>• Port <i>port name</i></li> <li>• Link-station <i>link station name</i></li> <li>• LU-Name <i>LU name</i></li> <li>• Connection-network <i>connection network name</i></li> <li>• Connection networks port interface (CN PORTIF) <i>CN name</i></li> <li>• Mode <i>mode name</i></li> <li>• Focal_point</li> <li>• local-pu</li> <li>• Routing_list</li> <li>• COS_mapping_table</li> </ul>	173
List	Lists the following from configuration memory: <ul style="list-style-type: none"> <li>• All</li> <li>• Node</li> <li>• Traces</li> <li>• Management</li> <li>• HPR</li> <li>• DLUR</li> <li>• Port <i>port name</i></li> <li>• Link-station <i>link name</i></li> <li>• LU-Name <i>LU name</i></li> <li>• Mode <i>mode name</i></li> <li>• Connection-network <i>connection network name</i></li> <li>• Focal_point</li> <li>• Routing_list</li> <li>• COS_mapping_table</li> </ul>	174
Activate_new_config	Reads the configuration into non-volatile configuration memory.	174
TN3270	Accesses the TN320E config> command prompt	175
Exit	Returns you to the previous command level. See “Exiting a Lower Level Environment” on page xxvi.	

**Note:** APPN will respond to a dynamic **reset** command at the interface level.

## APPN Configuration Command Detail

### Enable/Disable

Use the **enable/disable** command to enable (or disable):

**Syntax:**

```
enable      appn
[or disable] dlur
                port port name
```

### Set

Use the **set** command to set:

**Syntax:**

```
set   node
```

You will be prompted to enter values for the following parameters. The parameter range will be shown in parentheses ( ). The parameter default will be shown in square brackets [ ].

Table 4. Configuration Parameter List - APPN Routing

Parameter Information
<p><b>Parameter</b> Enable APPN</p>
<p><b>Valid Values</b> Yes, No</p>
<p><b>Default Value</b> Yes</p>
<p><b>Description</b> This parameter enables or disables the router as an APPN network node.</p> <p>This parameter enables both APPN and HPR routing capability for this network node which consists of defining the Network ID and CP name for this node. APPN, however, must be enabled on the particular ports on which you desire to support APPN routing. Additionally, support for HPR must be enabled on the particular APPN ports desired and must be supported by the particular link stations on those ports.</p> <p><b>Note:</b> HPR only supported on LAN, frame relay and PPP direct DLC ports.</p>

## APPN Configuration Commands

Table 4. Configuration Parameter List - APPN Routing (continued)

Parameter Information
<p><b>Parameter</b> Network ID (required)</p> <p><b>Valid Values</b> A string of 1 to 8 characters:</p> <ul style="list-style-type: none"><li>• First character: A to Z</li><li>• Second to eighth characters: A to Z, 0 to 9</li></ul> <p><b>Note:</b> A network identifier for an existing network, of which this router network node is to become a member, using the special characters @, \$, and # from the character set A, continues to be supported; however, these characters should not be used for new network IDs.</p> <p><b>Default Value</b> None</p> <p><b>Description</b> This parameter specifies the name of the APPN network to which this network node belongs. The network ID must be the same for all network nodes in the APPN network. Attached APPN end nodes and LEN end nodes can have different network IDs.</p>
<p><b>Parameter</b> Control point name (required)</p> <p><b>Valid Values</b> A string of 1 to 8 characters:</p> <ul style="list-style-type: none"><li>• First character: A to Z</li><li>• Second to eighth characters: A to Z, 0 to 9</li></ul> <p><b>Note:</b> An existing CP name that this node would be acquiring, using the special characters @, \$, and # from the character set A, continues to be supported; however, these characters should not be used for new CP names.</p> <p><b>Default</b> None</p> <p><b>Description</b> This parameter specifies the name of the CP for this APPN network node. The CP is responsible for managing the APPN network node and its resources. The CP name is the logical name of the APPN network node in the network. The CP name must be unique within the APPN network identified by the Network ID parameter.</p>



Table 4. Configuration Parameter List - APPN Routing (continued)

Parameter Information
<p><b>Parameter</b> Enable branch extender or border node</p> <p><b>Valid Values</b> 0 (enable neither)  1 (enable branch extender)  2 (enable border node)</p> <p><b>Default</b> 0</p> <p><b>Description</b> This parameter specifies whether branch extender function, border node function, or neither will be enabled on this node. If either function is enabled, appropriate additional questions will be asked.</p>
<p><b>Parameter</b> Permit search for unregistered LUs</p> <p><b>Valid Values</b> Yes or No</p> <p><b>Default</b> No</p> <p><b>Description</b> This parameter specifies whether this node (when acting as an End Node) can be searched for LUs even if the LUs were not registered with the network node server of the Branch Extender. If <i>yes</i> is specified, this node can be searched for LUs. <b>Note:</b> This question is asked only if <b>Enable Branch Extender or Border Node</b> parameter is set to <i>branch extender</i>.</p>
<p><b>Parameter</b> Subnet visit count</p> <p><b>Valid Values</b> 1 — 255</p> <p><b>Default</b> 3</p> <p><b>Description</b> Specifies the node level default for the maximum number of subnetworks that a multi-subnetwork session may traverse. The default may be overridden as part of port, link, or routing list configuration. <b>Note:</b> This is the first of the questions asked only if border node has been enabled.</p>

## APPN Configuration Commands

Table 4. Configuration Parameter List - APPN Routing (continued)

Parameter Information
<p><b>Parameter</b> Cache searches for (0-255) minutes</p> <p><b>Valid Values</b> 0 - 255</p> <p><b>Default</b> 8</p> <p><b>Description</b> Specifies how many minutes the BN retains information in the multi-subnet search cache once the search terminates.</p>
<p><b>Parameter</b> Maximum number of searches in cache</p> <p><b>Valid Values</b> 0 - 32765 (0=unlimited)</p> <p><b>Default</b> 0</p> <p><b>Description</b> Specifies the maximum number of entries in the multi-network search cache. Once this limit is reached, the oldest entries are discarded. <b>Note:</b> The primary mechanism for deletion of these entries is the cache search time value specified in <b>cache searches for (0-255) minutes</b>.</p>
<p><b>Parameter</b> Dynamic routing list updates</p> <p><b>Valid Values</b> 0 (none) - No dynamic entries are added.</p> <p>1 (full) - All native border nodes, all adjacent non-native border and network nodes, and nodes that know of similarly named destination LUs are added.</p> <p>2 (limited) - All native border nodes, all adjacent non-native border nodes and network nodes <b>with the same NETID</b>, and nodes that know of similarly named destination LUs are added.</p> <p><b>Default</b> 2</p> <p><b>Description</b> Indicates the degree to which, if any, that a BN can supplement configured routing list data with topology data learned by the operational code. This supplemental data is not saved in SRAM.</p>

## APPN Configuration Commands

Table 4. Configuration Parameter List - APPN Routing (continued)

Parameter Information
<p><b>Parameter</b> Enable routing list optimization</p> <p><b>Valid Values</b> Yes or No</p> <p><b>Default</b> Yes</p> <p><b>Description</b> Indicates whether or not a BN may reorder the operational code's temporary copy of a subnetwork routing list so that entries that are more likely to be successful are found first. <b>Note:</b> This is the last of the questions asked only if border node has been enabled.</p>
<p><b>Parameter</b> Route addition resistance</p> <p><b>Valid Values</b> 0 to 255</p> <p><b>Default Value</b> 128</p> <p><b>Description</b> This parameter indicates the desirability of routing through this node. This parameter is used in the class of service based route calculation. Lower values indicate higher levels of desirability.</p>
<p><b>Parameter</b> XID number for subarea connection (see table notes)</p> <p><b>Valid Values</b> A string of 5 hexadecimal digits</p> <p><b>Default</b> X'00000'</p> <p><b>Description</b> This parameter specifies a unique ID number (identifier) for the network node. The XID number is combined with an ID block number (which identifies a specific IBM product) to form an XID node identification. Node identifications are exchanged between adjacent nodes when the nodes are establishing a connection. The router network node automatically appends an ID block number to this parameter during the XID exchange to create an XID node identification.  The ID number you assign to this node must be unique within the APPN network identified by Network ID parameter. Contact your network administrator to verify that the ID number is unique.</p>
<p><b>Note:</b> Node identifications are normally exchanged between T2.1 nodes during CP-CP session establishment. If the network node is communicating with the IBM Virtual Telecommunications Access Method (VTAM) product through a T2.1 LEN node and the LEN node has a CP name defined for it, the XID number parameter is not required. If the adjacent LEN node is not a T2.1 node or does not have an explicitly defined CP name, the XID number parameter must be specified to establish a connection with the LEN node. VTAM versions prior to Version 3 Release 2 do not allow CP names to be defined for LEN nodes.</p>

## APPN Configuration Commands

### Syntax:

**set** high-performance routing

You will be prompted to enter values for the following parameters. The parameter range will be shown in parentheses ( ). The parameter default will be shown in square brackets [ ].

Table 5. Configuration Parameter List - High-Performance Routing (HPR)

Parameter Information
<p><b>Parameter</b> Maximum sessions for HPR connections</p> <p><b>Valid Values</b> 1 to 65535</p> <p><b>Default Value</b> 100</p> <p><b>Description</b> This parameter specifies the maximum number of sessions allowed on an HPR connection. An HPR connection is defined by the class of service (COS), the physical path (TGs), and the network connection end points.</p> <p>This parameter is applicable only when the router is the initiator of the BIND. If the number of sessions exceeds the specified value for this parameter, HPR will allocate another HPR (RTP) connection.</p>

Table 6. Configuration Parameter List - HPR Timer and Retry Options

Parameter Information
<p><i>Low transmission priority traffic</i></p>
<p><b>Parameter</b> RTP inactivity timer</p> <p><b>Valid Values</b> 1 to 3600 seconds</p> <p><b>Default Value</b> 180 seconds</p> <p><b>Description</b> This parameter specifies RTP's inactivity interval for HPR connections that carry traffic with <i>low</i> transmission priority. This is an end-to-end version of the LLC inactivity timer, Ti. If no receptions occur during this interval, RTP transmits a poll. Idle periods are monitored to ensure the integrity of the connection.</p>
<p><b>Parameter</b> Maximum RTP retries</p> <p><b>Valid Values</b> 0 to 10</p> <p><b>Default Value</b> 6</p> <p><b>Description</b> This parameter specifies the maximum number of retries before RTP initiates a path switch on an HPR connection that carries traffic with low transmission priority.</p>

## APPN Configuration Commands

Table 6. Configuration Parameter List - HPR Timer and Retry Options (continued)

Parameter Information
<p><b>Parameter</b> Path switch timer</p> <p><b>Valid Values</b> 0 to 7200 seconds</p> <p><b>Default Value</b> 180 seconds</p> <p><b>Description</b> This parameter specifies the maximum amount of time that a path switch may be attempted on an HPR connection carrying traffic with low transmission priority. A value of zero indicates that the path switch function is to be disabled, and a path switch will not be performed.</p>
<i>Medium transmission priority traffic</i>
<p><b>Parameter</b> RTP inactivity timer</p> <p><b>Valid Values</b> 1 to 3600 seconds</p> <p><b>Default Value</b> 180 seconds</p> <p><b>Description</b> This parameter specifies RTP's inactivity interval for HPR connections that carry traffic with <i>medium</i> transmission priority. This is an end-to-end version of the LLC inactivity timer, Ti. If no receptions occur during this interval, RTP transmits a poll. Idle periods are monitored to ensure the integrity of the connection.</p>
<p><b>Parameter</b> Maximum RTP retries</p> <p><b>Valid Values</b> 0 to 10</p> <p><b>Default Value</b> 6</p> <p><b>Description</b> This parameter specifies the maximum number of retries before RTP initiates a path switch on an HPR connection that carries traffic with medium transmission priority.</p>
<p><b>Parameter</b> Path switch timer</p> <p><b>Valid Values</b> 0 to 7200 seconds</p> <p><b>Default Value</b> 180 seconds</p> <p><b>Description</b> This parameter specifies the maximum amount of time that a path switch may be attempted on an HPR connection carrying traffic with medium transmission priority. A value of zero indicates that the path switch function is to be disabled, and a path switch will not be performed.</p>

## APPN Configuration Commands

Table 6. Configuration Parameter List - HPR Timer and Retry Options (continued)

Parameter Information
<i>High transmission priority traffic</i>
<p><b>Parameter</b> RTP inactivity timer</p> <p><b>Valid Values</b> 1 to 3600 seconds</p> <p><b>Default Value</b> 180 seconds</p> <p><b>Description</b> This parameter specifies RTP's inactivity interval for HPR connections that carry traffic with <i>high</i> transmission priority. This is an end-to-end version of the LLC inactivity timer, Ti. If no receptions occur during this interval, RTP transmits a poll. Idle periods are monitored to ensure the integrity of the connection.</p>
<p><b>Parameter</b> Maximum RTP retries</p> <p><b>Valid Values</b> 0 to 10</p> <p><b>Default Value</b> 6</p> <p><b>Description</b> This parameter specifies the maximum number of retries before RTP initiates a path switch on an HPR connection that carries traffic with high transmission priority.</p>
<p><b>Parameter</b> Path switch timer</p> <p><b>Valid Values</b> 0 to 7200 seconds</p> <p><b>Default Value</b> 180 seconds</p> <p><b>Description</b> This parameter specifies the maximum amount of time that a path switch may be attempted on an HPR connection carrying traffic with high transmission priority. A value of zero indicates that the path switch function is to be disabled, and a path switch will not be performed.</p>
<i>Network transmission priority traffic</i>

## APPN Configuration Commands

Table 6. Configuration Parameter List - HPR Timer and Retry Options (continued)

Parameter Information
<p><b>Parameter</b> RTP inactivity timer</p> <p><b>Valid Values</b> 1 to 3600 seconds</p> <p><b>Default Value</b> 180 seconds</p> <p><b>Description</b> This parameter specifies RTP's inactivity interval for HPR connections that carry traffic with <i>network</i> transmission priority. This is an end-to-end version of the LLC inactivity timer, Ti. If no receptions occur during this interval, RTP transmits a poll. Idle periods are monitored to ensure the integrity of the connection.</p>
<p><b>Parameter</b> Maximum RTP retries</p> <p><b>Valid Values</b> 0 to 10</p> <p><b>Default Value</b> 6</p> <p><b>Description</b> This parameter specifies the maximum number of retries before RTP initiates a path switch on an HPR connection that carries traffic with network transmission priority.</p>
<p><b>Parameter</b> Path switch timer</p> <p><b>Valid Values</b> 0 to 7200 seconds</p> <p><b>Default Value</b> 180 seconds</p> <p><b>Description</b> This parameter specifies the maximum amount of time that a path switch may be attempted on an HPR connection carrying traffic with network transmission priority. A value of zero indicates that the path switch function is to be disabled, and a path switch will not be performed.</p>

### Syntax:

set    dlur

You will be prompted to enter values for the following parameters. The parameter range will be shown in parentheses ( ). The parameter default will be shown in square brackets [ ].

## APPN Configuration Commands

Table 7. Configuration Parameter List - Dependent LU Requester

Parameter Information
<p><b>Parameter</b> Enable dependent LU requester (DLUR) on this network node</p> <p><b>Valid Values</b> Yes, No</p> <p><b>Default Value</b> No</p> <p><b>Description</b> This parameter specifies whether a dependent LU requester is to be functionally enabled on this node.</p>
<p><b>Parameter</b> Default fully-qualified CP name of primary DLUS (required when DLUR is enabled)</p> <p><b>Valid Values</b> A string of up to 17 characters in the form of <i>netID.CPname</i>, where:</p> <ul style="list-style-type: none"><li>• <i>netID</i> is a network ID from 1 to 8 characters</li><li>• <i>CPname</i> is a CP name from 1 to 8 characters</li></ul> <p>Each name must conform to the following rules:</p> <ul style="list-style-type: none"><li>• First character: A to Z</li><li>• Second to eighth characters: A to Z, 0 to 9</li></ul> <p><b>Note:</b> An existing fully-qualified CP name, using the special characters @, \$, and # from the character set A, continues to be supported; however, these characters should not be used for new CP names.</p> <p><b>Default Value</b> None</p> <p><b>Description</b> This parameter specifies the fully-qualified control point (CP) name of the dependent LU server (DLUS) that is used by default. The default primary server may be overridden on a link station basis. The default server is used for incoming requests from downstream PUs when a primary DLUS has not been specified for the associated link station.</p>



## APPN Configuration Commands

Table 7. Configuration Parameter List - Dependent LU Requester (continued)

Parameter Information
<p><b>Parameter</b> Default fully-qualified CP name of backup dependent LU server (DLUS)</p> <p><b>Valid Values</b> A string of up to 17 characters in the form of <i>netID.CPname</i>, where:</p> <ul style="list-style-type: none"><li>• <i>netID</i> is a network ID from 1 to 8 characters</li><li>• <i>CPname</i> is a CP name from 1 to 8 characters</li></ul> <p>Each name must conform to the following rules:</p> <ul style="list-style-type: none"><li>• First character: A to Z</li><li>• Second to eighth characters: A to Z, 0 to 9</li></ul> <p><b>Note:</b> An existing fully-qualified CP name, using the special characters @, \$, and # from the character set A, continues to be supported; however, these characters should not be used for new CP names.</p> <p><b>Default Value</b> Null</p> <p><b>Description</b> This parameter specifies the fully-qualified CP name of the dependent LU server (DLUS) that is used as the default backup. A backup is not required, and the null value (representing no entry) indicates the absence of a default backup server. The default backup server may be overridden on a link station basis.</p>
<p><b>Parameter</b> Perform retries to restore disrupted pipe</p> <p><b>Valid Values</b> Yes, No</p> <p><b>Default Value</b> No</p> <p><b>Description</b> This parameter specifies whether DLUR will attempt to reestablish the pipe to a DLUS after a pipe failure. If DLUR receives a non-disruptive UNBIND and this parameter is No, DLUR waits indefinitely for a DLUS to reestablish the broken pipe. If the pipe fails for any other reason and this parameter is No, DLUR attempts to reach the primary DLUS once. If this is unsuccessful, DLUR attempts to reach the backup DLUS. If this attempt also fails, DLUR waits indefinitely for a DLUS to reestablish the pipe.</p> <p>See “DLUR Retry Algorithm” on page 41 for a description of the retry algorithm.</p>

## APPN Configuration Commands

Table 7. Configuration Parameter List - Dependent LU Requester (continued)

Parameter Information
<p><b>Parameter</b> Delay before initiating retries</p> <p><b>Valid Values</b> 0 to 2 756 000 seconds</p> <p><b>Default Value</b> 120 seconds</p> <p><b>Description</b> This parameter specifies an amount of time for two different cases when the pipe between the DLUR and its DLUS is broken.</p> <ul style="list-style-type: none"> <li>For the case of receiving a non-disruptive UNBIND: This parameter specifies the amount of time the DLUR must wait before attempting to reach the primary DLUS. A value of 0 indicates immediate retry by the DLUR.</li> <li>For all other cases of pipe failure: The DLUR will try the primary DLUS and then the backup DLUS immediately. If this fails, DLUR will wait for the amount of time specified by the minimum of the <i>short retry timer</i> and this parameter before attempting to reach the primary DLUS.</li> </ul> <p>See “DLUR Retry Algorithm” on page 41 for a complete description of the retry algorithm.</p>
<p><b>Parameter</b> Perform short retries to restore disrupted pipe</p> <p><b>Valid Values</b> Yes, No</p> <p><b>Default Value</b> If <i>Perform retries to restore disrupted pipes</i> is Yes, then the default value is Yes. Otherwise, the default is No.</p> <p><b>Description</b> See “DLUR Retry Algorithm” on page 41 for a complete description of the retry algorithm.</p>
<p><b>Parameter</b> Short retry timer</p> <p><b>Valid Values</b> 0 to 2 756 000 seconds</p> <p><b>Default Value</b> 120 seconds</p> <p><b>Description</b> In all cases of pipe failure other than non-disruptive UNBIND, the minimum of <i>Delay before initiating retries</i> and this parameter specifies the amount of time DLUR will wait before attempting to reach the primary DLUS after an attempt to establish this connection has failed.</p> <p>See “DLUR Retry Algorithm” on page 41 for a complete description of the retry algorithm.</p>

## APPN Configuration Commands

Table 7. Configuration Parameter List - Dependent LU Requester (continued)

Parameter Information
<p><b>Parameter</b> Short retry count</p> <p><b>Valid Values</b> 0 to 65 535</p> <p><b>Default Value</b> 5</p> <p><b>Description</b> In all cases of pipe failure other than non-disruptive UNBIND, this parameter specifies the number of times the DLUR will attempt to perform short retries to reach the DLUS after an attempt to establish this connection has failed.</p> <p>See “DLUR Retry Algorithm” on page 41 for a complete description of the retry algorithm.</p>
<p><b>Parameter</b> Perform long retries to restore disrupted pipe</p> <p><b>Valid Values</b> Yes, No</p> <p><b>Default Value</b> If <i>Perform retries to restore disrupted pipes</i> is Yes, then the default value is Yes. Otherwise, the default is No</p> <p><b>Description</b> See “DLUR Retry Algorithm” on page 41 for a complete description of the retry algorithm.</p>
<p><b>Parameter</b> Long retry timer</p> <p><b>Valid Values</b> 0 to 2 756 000 seconds</p> <p><b>Default Value</b> 300 seconds</p> <p><b>Description</b> This parameter specifies the time DLUR will wait when performing long retries.</p> <p>See “DLUR Retry Algorithm” on page 41 for a complete description of the retry algorithm.</p>

### Syntax:

**set** tuning

You will be prompted to enter values for the following parameters. The parameter range will be shown in parentheses ( ). The parameter default will be shown in square brackets [ ].

**Note:** You will have to re-boot in order for the changes you specify to take place.

## APPN Configuration Commands

Table 8. Configuration Parameter List - APPN Node Tuning

Parameter Information
<p><b>Parameter</b> Maximum number of adjacent nodes</p> <p><b>Valid Values</b> 1 to 2 800</p> <p><b>Default</b> 100</p> <p><b>Description</b> This parameter is an estimate of the maximum number of nodes that you expect to be logically adjacent to this router network node at any one time.</p> <p>This parameter is used along with the <i>Maximum number of ISR sessions</i> parameter by the automatic tuning algorithm to calculate the values for the <i>Maximum shared memory</i> and <i>Maximum cached directory entries</i> tuning parameters.</p> <p>This parameter is configurable using the Configuration Program only.</p>
<p><b>Parameter</b> Maximum number of network nodes sharing the same APPN network id</p> <p><b>Valid Values</b> 10 to 8 000</p> <p><b>Default</b> 50</p> <p><b>Description</b> This parameter is an estimate of the maximum number of nodes that you expect in the subnetwork (that is, in the topology known by this node).</p> <p>This parameter is configurable using the Configuration Program only.</p>
<p><b>Parameter</b> Maximum number of TGs connecting network nodes with the same APPN network id</p> <p><b>Valid Values</b> 9 to 64 000</p> <p><b>Default</b> 3 times the value of the <i>maximum number of network nodes in the subnetwork</i>.</p> <p><b>Description</b> This parameter is an estimate of the maximum number of TGs connecting network nodes in the subnetwork (that is, in the topology known by this node).</p> <p>This parameter is configurable using the Configuration Program only.</p>

Table 8. Configuration Parameter List - APPN Node Tuning (continued)

Parameter Information
<p><b>Parameter</b> Maximum number of ISR sessions</p> <p><b>Valid Values</b> 10 to 7 500</p> <p><b>Default Value</b> 200</p> <p><b>Description</b> This parameter specifies an estimate of the maximum number of intermediate session routing sessions (ISR) expected to be supported by this router network node at any one time.</p> <p>This parameter is used in conjunction with the Maximum number of adjacent nodes parameter by the automatic tuning algorithm to calculate the values for the Maximum shared memory and Maximum cached directory entries tuning parameters.</p> <p>This parameter is configurable using the Configuration Program only.</p>
<p><b>Parameter</b> Percent of adjacent nodes with CP-CP sessions using HPR</p> <p><b>Valid Values</b> 0 to 100%</p> <p><b>Default Value</b> 0 (none)</p> <p><b>Description</b> This parameter specifies an estimate of the maximum number of adjacent EN and NN, with CP-CP sessions using option set 1402 (Control Flows over RTP option set).</p> <p>This parameter is configurable using the Configuration Program only.</p>
<p><b>Parameter</b> Maximum percent of ISR sessions using HPR data connections</p> <p><b>Valid Values</b> 0 to 100 percent</p> <p><b>Default</b> 0 percent</p> <p><b>Description</b> This parameter specifies the largest percentage of ISR sessions that use ISR to HPR mappings.</p> <p>This parameter is configurable using the Configuration Program only.</p>

## APPN Configuration Commands

Table 8. Configuration Parameter List - APPN Node Tuning (continued)

Parameter Information
<p><b>Parameter</b> Percent adjacent nodes that function as DLUR PU nodes</p> <p><b>Valid Values</b> 0 to 100 percent</p> <p><b>Default</b> 0 percent</p> <p><b>Description</b> This parameter specifies the largest percentage of adjacent nodes allowed to function as adjacent DLUR PU nodes.</p> <p>This parameter is configurable using the Configuration Program only.</p>
<p><b>Parameter</b> Maximum percent ISR sessions used by DLUR LUs</p> <p><b>Valid Values</b> 0 to 100 percent</p> <p><b>Default</b> 0 percent</p> <p><b>Description</b> This parameter specifies the largest percentage of ISR sessions used by DLUR LUs.</p> <p>This parameter is configurable using the Configuration Program only.</p>
<p><b>Parameter</b> Maximum number of ISR accounting memory buffers</p> <p><b>Valid Values</b> 0 or 1</p> <p><b>Default Value</b> 0 (default is 1 if ISR session accounting is enabled)</p> <p><b>Description</b> This parameter specifies a maximum number of buffers to be reserved for ISR session accounting.</p> <p>This parameter is configurable using the Configuration Program only.</p>
<p><b>Parameter</b> Maximum memory records per ISR accounting buffer</p> <p><b>Valid Values</b> 0 to 2000</p> <p><b>Default Value</b> 100</p> <p><b>Description</b> This parameter specifies a maximum number of memory records per ISR accounting buffer.</p> <p>This parameter is configurable using the Configuration Program only.</p>

## APPN Configuration Commands

Table 8. Configuration Parameter List - APPN Node Tuning (continued)

Parameter Information
<p><b>Parameter</b> Override tuning algorithm</p> <p><b>Valid Values</b> Yes, No</p> <p><b>Default Value</b> No</p> <p><b>Description</b> When enabled, this parameter overrides the tuning calculations generated by the Command Line and enables you to specify explicit values for the Maximum shared memory parameter and the Maximum cached directory entries parameter.</p> <p>This parameter is configurable using the Configuration Program only.</p>
<p><b>Parameter</b> Number of local-pus for TN3270E support</p> <p><b>Valid Values</b></p> <p><b>Default Value</b></p> <p><b>Description</b> This parameter specifies the number of local PUs that are available for TN3270 support.</p> <p>This parameter is configurable using the Configuration Program only.</p>
<p><b>Parameter</b> Total number of LUs for TN3270E</p> <p><b>Valid Values</b></p> <p><b>Default Value</b></p> <p><b>Description</b> This parameter specifies the total number of LUs available for TN3270E support.</p> <p>This parameter is configurable using the Configuration Program only.</p>

## APPN Configuration Commands

Table 8. Configuration Parameter List - APPN Node Tuning (continued)

Parameter Information
<p><b>Parameter</b> Maximum shared memory</p> <p><b>Valid Values</b> 0 - 5 108 KB</p> <p><b>Default Value</b> 5 108 KB</p> <p><b>Description</b> This parameter specifies the amount of shared memory within the router that is allocated to the APPN network node. APPN uses its shared memory allocation to perform network operations and to maintain required tables and directories.</p> <p>You can allow APPN to have a 4K RU size by setting <i>percent of APPN shared memory used for buffers</i> to a sufficiently large value to allow at least 1 Megabyte of memory to be available to the buffer manager.</p> <p>This parameter is configurable using the Configuration Program and from <b>talk 6</b></p>
<p><b>Parameter</b> Percent of APPN shared memory to be used for buffers</p> <p><b>Valid Values</b> 10 to 50</p> <p><b>Default</b> 10% or 512 Kilobytes, whichever is larger.</p> <p><b>Description</b> This parameter specifies the amount of shared memory that APPN will use for buffers.</p> <p>You can allow APPN to have a 4K RU size by setting <i>maximum shared memory</i> to at least 1 Megabyte and setting <i>percent of APPN shared memory used for buffers</i> to a sufficiently large value to allow at least 1 Megabyte of memory to be available to the buffer manager.</p> <p>This parameter is configurable using the Configuration Program and from <b>talk 6</b></p>
<p><b>Parameter</b> Maximum cached directory entries</p> <p><b>Valid Values</b> 0 to 65 535</p> <p><b>Default</b> 4000</p> <p><b>Description</b> This parameter specifies the number of directory entries to be stored or cached by the router network node. If a directory entry for a node is cached, the router does not need to broadcast a search request to locate the node. This reduces the time it takes to initiate sessions with the node.</p> <p>This parameter is configurable using the Configuration Program and from <b>talk 6</b></p>

### Syntax:

**set** traces



## APPN Configuration Commands

You will be prompted to enter values for the following parameters. The parameter range will be shown in parentheses ( ). The parameter default will be shown in square brackets [ ].

Table 9. Configuration Parameter List - Trace Setup Questions

Parameter Information
<p><b>Parameter</b> Turn all trace flags off</p> <p><b>Valid Values</b> Yes, No</p> <p><b>Default Value</b> No</p> <p><b>Description</b> This parameter enables or disables trace flags.</p>
<p><b>Parameter</b> Edit Node-Level Traces</p> <p><b>Valid Values</b> Yes, No</p> <p><b>Default Value</b> No</p> <p><b>Description</b> This parameter enables or disables this APPN trace option. See Table 10 on page 100 for the set of questions you will be asked if this option is enabled.</p>
<p><b>Parameter</b> Edit Interprocess Signals</p> <p><b>Valid Values</b> Yes, No</p> <p><b>Default Value</b> No</p> <p><b>Description</b> This parameter enables or disables this APPN trace option. See Table 11 on page 105 for the set of questions you will be asked if this option is enabled.</p>
<p><b>Parameter</b> Edit Module Entry and Exit</p> <p><b>Valid Values</b> Yes, No</p> <p><b>Default Value</b> No</p> <p><b>Description</b> This parameter enables or disables this APPN trace option. See Table 12 on page 109 for the set of questions you will be asked if this option is enabled.</p>

## APPN Configuration Commands

Table 9. Configuration Parameter List - Trace Setup Questions (continued)

Parameter Information
<b>Parameter</b> Edit General
<b>Valid Values</b> Yes, No
<b>Default Value</b> No
<b>Description</b> This parameter enables or disables this APPN trace option. See Table 13 on page 111 for the set of questions you will be asked if this option is enabled.

Table 10. Configuration Parameter List - Node Level Traces

Parameter Information
<b>Parameter</b> Process management
<b>Valid Values</b> Yes, No
<b>Default Value</b> No
<b>Description</b> This parameter enables or disables this APPN trace option. When enabled, the trace option causes the router trace facility to gather data about the management of processes within the APPN network node, including the creation and termination of processes, processes entering a wait state, and the posting of processes.
<b>Parameter</b> Process to process communication
<b>Valid Values</b> Yes, No
<b>Default Value</b> No
<b>Description</b> This parameter enables or disables this APPN trace option. When enabled, the trace option causes the router trace facility to gather data about messages exchanged between processes in the APPN network node, including the queuing and receipt of such messages.

## APPN Configuration Commands

Table 10. Configuration Parameter List - Node Level Traces (continued)

Parameter Information
<p><b>Parameter</b> Locking</p> <p><b>Valid Values</b> Yes, No</p> <p><b>Default Value</b> No</p> <p><b>Description</b> This parameter enables or disables this APPN trace option. When enabled, the trace option causes the router trace facility to gather data about locks that were obtained and released on processes in the APPN network node.</p>
<p><b>Parameter</b> Miscellaneous tower activities</p> <p><b>Valid Values</b> Yes, No</p> <p><b>Default Value</b> No</p> <p><b>Description</b> This parameter enables or disables this APPN trace option. When enabled, the trace option causes the router trace facility to gather data about miscellaneous activities within the APPN network node.</p>
<p><b>Parameter</b> I/O to and from the system</p> <p><b>Valid Values</b> Yes, No</p> <p><b>Default Value</b> No</p> <p><b>Description</b> This parameter enables or disables this APPN trace option. When enabled, the trace option causes the router trace facility to gather data about the flow of messages entering and exiting the APPN network node.</p>
<p><b>Parameter</b> Storage management</p> <p><b>Valid Values</b> Yes, No</p> <p><b>Default Value</b> No</p> <p><b>Description</b> This parameter enables or disables this APPN trace option. When enabled, the trace option causes the router trace facility to gather data about any shared memory that was obtained and released by the APPN network node.</p>

## APPN Configuration Commands

Table 10. Configuration Parameter List - Node Level Traces (continued)

Parameter Information
<p><b>Parameter</b> Queue data type management</p> <p><b>Valid Values</b> Yes, No</p> <p><b>Default Value</b> No</p> <p><b>Description</b> This parameter enables or disables this APPN trace option. When enabled, the trace option causes the router trace facility to gather data about all calls in the APPN network node that manage general purpose queues.</p>
<p><b>Parameter</b> Table data type management</p> <p><b>Valid Values</b> Yes, No</p> <p><b>Default Value</b> No</p> <p><b>Description</b> This parameter enables or disables this APPN trace option. When enabled, the trace option causes the router trace facility to gather data about all calls in the APPN network node that manage general purpose tables, including calls to add table entries and calls to query tables for specific entries.</p>
<p><b>Parameter</b> Buffer management</p> <p><b>Valid Values</b> Yes, No</p> <p><b>Default Value</b> No</p> <p><b>Description</b> This parameter enables or disables this APPN trace option. When enabled, the trace option causes the router trace facility to gather data about buffers in the APPN network node that were obtained and released.</p>
<p><b>Parameter</b> Configuration control</p> <p><b>Valid Values</b> Yes, No</p> <p><b>Default Value</b> No</p> <p><b>Description</b> This parameter enables or disables this APPN trace option. When enabled, the trace option causes the router trace facility to gather data about the activities of the configuration control component of the APPN network node. The configuration control component manages information about node resources.</p>

## APPN Configuration Commands

Table 10. Configuration Parameter List - Node Level Traces (continued)

Parameter Information
<p><b>Parameter</b> Timer service</p> <p><b>Valid Values</b> Yes, No</p> <p><b>Default Value</b> No</p> <p><b>Description</b> This parameter enables or disables this APPN trace option. When enabled, the trace option causes the router trace facility to gather data about requests for timer service from the APPN network node.</p>
<p><b>Parameter</b> Service provider management</p> <p><b>Valid Values</b> Yes, No</p> <p><b>Default Value</b> No</p> <p><b>Description</b> This parameter enables or disables this APPN trace option. When enabled, the trace option causes the router trace facility to gather data about the definition and enabling or disabling of services within the APPN network node.</p>
<p><b>Parameter</b> Inter-process message segmenting</p> <p><b>Valid Values</b> Yes, No</p> <p><b>Default Value</b> No</p> <p><b>Description</b> This parameter enables or disables this APPN trace option. When enabled, the trace option causes the router trace facility to gather data about the buffer transfer and freeing of chained messages within the APPN network node.</p>
<p><b>Parameter</b> Control of processes outside scope of this tower</p> <p><b>Valid Values</b> Yes, No</p> <p><b>Default Value</b> No</p> <p><b>Description</b> This parameter enables or disables this APPN trace option. When enabled, the trace option causes the router trace facility to gather data about the definition and activation of processes external to this APPN network node, such as when the node operator facility (NOF) defines the external process configuration control.</p>

## APPN Configuration Commands

Table 10. Configuration Parameter List - Node Level Traces (continued)

Parameter Information
<p><b>Parameter</b> Monitoring existence of processes, services, towers</p> <p><b>Valid Values</b> Yes, No</p> <p><b>Default Value</b> No</p> <p><b>Description</b> This parameter enables or disables this APPN trace option. When enabled, the trace option causes the router trace facility to gather data about requests that start or stop the monitoring of processes or services within the APPN network node.</p>
<p><b>Parameter</b> Distributed environment control</p> <p><b>Valid Values</b> Yes, No</p> <p><b>Default Value</b> No</p> <p><b>Description</b> This parameter enables or disables this APPN trace option. When enabled, the trace option causes the router trace facility to gather data about requests within the APPN network node that define subsystems and create environments.</p>
<p><b>Parameter</b> Process to service dialogs</p> <p><b>Valid Values</b> Yes, No</p> <p><b>Default Value</b> No</p> <p><b>Description</b> This parameter enables or disables this APPN trace option. When enabled, this trace option causes the router trace facility to gather data about all calls within the APPN network node that open, close, or send data on a dialog.</p>
<p><b>Parameter</b> AVL Tree Support</p> <p><b>Valid Values</b> Yes, No</p> <p><b>Default</b> No</p> <p><b>Description</b> This parameter enables or disables this APPN trace option. When enabled, the trace option causes the router trace facility to gather data about all calls that manage AVL trees.</p>

## APPN Configuration Commands

Table 11. Configuration Parameter List - Inter-process Signals Traces

Parameter Information
<p><b>Parameter</b> Address space manager</p> <p><b>Valid Values</b> Yes, No</p> <p><b>Default Value</b> No</p> <p><b>Description</b> This parameter enables or disables this APPN trace option. When enabled, this parameter informs the trace facility to include trace data about inter-process signals from the address space manager component.</p>
<p><b>Parameter</b> Attach manager</p> <p><b>Valid Values</b> Yes, No</p> <p><b>Default Value</b> No</p> <p><b>Description</b> This parameter enables or disables this APPN trace option. When enabled, this parameter informs the trace facility to include trace data about inter-process signals from the attach manager component.</p>
<p><b>Parameter</b> Configuration services</p> <p><b>Valid Values</b> Yes, No</p> <p><b>Default Value</b> No</p> <p><b>Description</b> This parameter enables or disables this APPN trace option. When enabled, this parameter informs the trace facility to include trace data about inter-process signals from the configuration services component.</p>
<p><b>Parameter</b> Dependent LU requester</p> <p><b>Valid Values</b> Yes, No</p> <p><b>Default Value</b> No</p> <p><b>Description</b> This parameter enables or disables this APPN trace option. When enabled, this parameter informs the trace facility to include trace data about inter-process signals from the dependent LU requester component.</p>

## APPN Configuration Commands

Table 11. Configuration Parameter List - Inter-process Signals Traces (continued)

Parameter Information
<p><b>Parameter</b> Directory services</p> <p><b>Valid Values</b> Yes, No</p> <p><b>Default Value</b> No</p> <p><b>Description</b> This parameter enables or disables this APPN trace option. When enabled, this parameter informs the trace facility to include trace data about inter-process signals from the directory services component.</p>
<p><b>Parameter</b> Half Session</p> <p><b>Valid Values</b> Yes, No</p> <p><b>Default Value</b> No</p> <p><b>Description</b> This parameter enables or disables this APPN trace option. When enabled, this parameter informs the trace facility to include trace data about inter-process signals from the half session component.</p>
<p><b>Parameter</b> HPR Path Control</p> <p><b>Valid Values</b> Yes, No</p> <p><b>Default Value</b> No</p> <p><b>Description</b> This parameter enables or disables this APPN trace option. When enabled, this parameter informs the trace facility to include trace data about inter-process signals from the HPR path control component.</p>
<p><b>Parameter</b> LUA RUI</p> <p><b>Valid Values</b> Yes, No</p> <p><b>Default Value</b> No</p> <p><b>Description</b> This parameter enables or disables this APPN trace option. When enabled, this parameter informs the trace facility to include trace data about inter-process signals from the LUA RUI component.</p>



## APPN Configuration Commands

Table 11. Configuration Parameter List - Inter-process Signals Traces (continued)

Parameter Information
<p><b>Parameter</b> Management Services</p> <p><b>Valid Values</b> Yes, No</p> <p><b>Default Value</b> No</p> <p><b>Description</b> This parameter enables or disables this APPN trace option. When enabled, this parameter informs the trace facility to include trace data about inter-process signals from the management services component.</p>
<p><b>Parameter</b> Node Operator Facility</p> <p><b>Valid Values</b> Yes, No</p> <p><b>Default Value</b> No</p> <p><b>Description</b> This parameter enables or disables this APPN trace option. When enabled, this parameter informs the trace facility to include trace data about inter-process signals from the node operator facility component.</p>
<p><b>Parameter</b> Path Control</p> <p><b>Valid Values</b> Yes, No</p> <p><b>Default Value</b> No</p> <p><b>Description</b> This parameter enables or disables this APPN trace option. When enabled, this parameter informs the trace facility to include trace data about inter-process signals from the path control component.</p>
<p><b>Parameter</b> Presentation Services</p> <p><b>Valid Values</b> Yes, No</p> <p><b>Default Value</b> No</p> <p><b>Description</b> This parameter enables or disables this APPN trace option. When enabled, this parameter informs the trace facility to include trace data about inter-process signals from the presentation services component.</p>

## APPN Configuration Commands

Table 11. Configuration Parameter List - Inter-process Signals Traces (continued)

Parameter Information
<p><b>Parameter</b> Resource manager</p> <p><b>Valid Values</b> Yes, No</p> <p><b>Default Value</b> No</p> <p><b>Description</b> This parameter enables or disables this APPN trace option. When enabled, this parameter informs the trace facility to include trace data about inter-process signals from the resource manager component.</p>
<p><b>Parameter</b> Session connector manager</p> <p><b>Valid Values</b> Yes, No</p> <p><b>Default Value</b> No</p> <p><b>Description</b> This parameter enables or disables this APPN trace option. When enabled, this parameter informs the trace facility to include trace data about inter-process signals from the session connector manager component.</p>
<p><b>Parameter</b> Session connector</p> <p><b>Valid Values</b> Yes, No</p> <p><b>Default Value</b> No</p> <p><b>Description</b> This parameter enables or disables this APPN trace option. When enabled, this parameter informs the trace facility to include trace data about inter-process signals from the session connector component.</p>
<p><b>Parameter</b> Session manager</p> <p><b>Valid Values</b> Yes, No</p> <p><b>Default Value</b> No</p> <p><b>Description</b> This parameter enables or disables this APPN trace option. When enabled, this parameter informs the trace facility to include trace data about inter-process signals from the session manager component.</p>

## APPN Configuration Commands

Table 11. Configuration Parameter List - Inter-process Signals Traces (continued)

Parameter Information
<p><b>Parameter</b> Session services</p> <p><b>Valid Values</b> Yes, No</p> <p><b>Default Value</b> No</p> <p><b>Description</b> This parameter enables or disables this APPN trace option. When enabled, this parameter informs the trace facility to include trace data about inter-process signals from the session services component.</p>
<p><b>Parameter</b> Topology and routing services</p> <p><b>Valid Values</b> Yes, No</p> <p><b>Default Value</b> No</p> <p><b>Description</b> This parameter enables or disables this APPN trace option. When enabled, this parameter informs the trace facility to include trace data about inter-process signals from the topology and routing services component.</p>

Table 12. Configuration Parameter List - Module Entry and Exit Traces

Parameter Information
<p><b>Parameter</b> Attach manager</p> <p><b>Valid Values</b> Yes, No</p> <p><b>Default Value</b> No</p> <p><b>Description</b> This parameter enables or disables this APPN trace option. When enabled, this parameter informs the trace facility to include trace data about module entry and exit information from the attach manager component.</p>
<p><b>Parameter</b> Half session</p> <p><b>Valid Values</b> Yes, No</p> <p><b>Default Value</b> No</p> <p><b>Description</b> This parameter enables or disables this APPN trace option. When enabled, this parameter informs the trace facility to include trace data about module entry and exit information from the half session component.</p>

## APPN Configuration Commands

Table 12. Configuration Parameter List - Module Entry and Exit Traces (continued)

Parameter Information
<p><b>Parameter</b> LUA RUI</p> <p><b>Valid Values</b> Yes, No</p> <p><b>Default Value</b> No</p> <p><b>Description</b> This parameter enables or disables this APPN trace option. When enabled, this parameter informs the trace facility to include trace data about module entry and exit information from the LUA RUI component.</p>
<p><b>Parameter</b> Node operator facility</p> <p><b>Valid Values</b> Yes, No</p> <p><b>Default Value</b> No</p> <p><b>Description</b> This parameter enables or disables this APPN trace option. When enabled, this parameter informs the trace facility to include trace data about module entry and exit information from the node operator facility component.</p>
<p><b>Parameter</b> Presentation services</p> <p><b>Valid Values</b> Yes, No</p> <p><b>Default Value</b> No</p> <p><b>Description</b> This parameter enables or disables this APPN trace option. When enabled, this parameter informs the trace facility to include trace data about module entry and exit information from the presentation services component.</p>
<p><b>Parameter</b> Rapid transport protocol</p> <p><b>Valid Values</b> Yes, No</p> <p><b>Default Value</b> No</p> <p><b>Description</b> This parameter enables or disables this APPN trace option. When enabled, this parameter informs the trace facility to include trace data about module entry and exit information from the rapid transport control component.</p>

## APPN Configuration Commands

Table 12. Configuration Parameter List - Module Entry and Exit Traces (continued)

Parameter Information
<p><b>Parameter</b> Resource manager</p> <p><b>Valid Values</b> Yes, No</p> <p><b>Default Value</b> No</p> <p><b>Description</b> This parameter enables or disables this APPN trace option. When enabled, this parameter informs the trace facility to include trace data about module entry and exit information from the resource manager component.</p>
<p><b>Parameter</b> Session manager</p> <p><b>Valid Values</b> Yes, No</p> <p><b>Default Value</b> No</p> <p><b>Description</b> This parameter enables or disables this APPN trace option. When enabled, this parameter informs the trace facility to include trace data about module entry and exit information from the session manager component.</p>

Table 13. Configuration Parameter List - General Component Level Traces

Parameter Information
<p><b>Parameter</b> Accounting services</p> <p><b>Valid Values</b> Yes, No</p> <p><b>Default Value</b> No</p> <p><b>Description</b> This parameter enables or disables this APPN trace option. When enabled, this parameter informs the trace facility to include trace data about general information from the accounting services component.</p>
<p><b>Parameter</b> Address space manager</p> <p><b>Valid Values</b> Yes, No</p> <p><b>Default Value</b> No</p> <p><b>Description</b> This parameter enables or disables this APPN trace option. When enabled, this parameter informs the trace facility to include trace data about general information from the address space manager component.</p>

## APPN Configuration Commands

Table 13. Configuration Parameter List - General Component Level Traces (continued)

Parameter Information
<p><b>Parameter</b> Architected transaction programs</p> <p><b>Valid Values</b> Yes, No</p> <p><b>Default Value</b> No</p> <p><b>Description</b> This parameter enables or disables this APPN trace option. When enabled, this parameter informs the trace facility to include trace data about general information from the architected transaction programs component.</p>
<p><b>Parameter</b> Configuration services</p> <p><b>Valid Values</b> Yes, No</p> <p><b>Default Value</b> No</p> <p><b>Description</b> This parameter enables or disables this APPN trace option. When enabled, this parameter informs the trace facility to include trace data about general information from the configuration services component.</p>
<p><b>Parameter</b> Dependent LU requester</p> <p><b>Valid Values</b> Yes, No</p> <p><b>Default Value</b> No</p> <p><b>Description</b> This parameter enables or disables this APPN trace option. When enabled, this parameter informs the trace facility to include trace data about general information from the dependent LU requester component.</p>
<p><b>Parameter</b> Directory services</p> <p><b>Valid Values</b> Yes, No</p> <p><b>Default Value</b> No</p> <p><b>Description</b> This parameter enables or disables this APPN trace option. When enabled, this parameter informs the trace facility to include trace data about general information from the directory services component.</p>

## APPN Configuration Commands

Table 13. Configuration Parameter List - General Component Level Traces (continued)

Parameter Information
<p><b>Parameter</b> HPR path control</p> <p><b>Valid Values</b> Yes, No</p> <p><b>Default Value</b> No</p> <p><b>Description</b> This parameter enables or disables this APPN trace option. When enabled, this parameter informs the trace facility to include trace data about general information from the HPR path control component.</p>
<p><b>Parameter</b> LUA RUI</p> <p><b>Valid Values</b> Yes, No</p> <p><b>Default Value</b> No</p> <p><b>Description</b> This parameter enables or disables this APPN trace option. When enabled, this parameter informs the trace facility to include trace data about general information from the LUA RUI component.</p>
<p><b>Parameter</b> Management services</p> <p><b>Valid Values</b> Yes, No</p> <p><b>Default Value</b> No</p> <p><b>Description</b> This parameter enables or disables this APPN trace option. When enabled, this parameter informs the trace facility to include trace data about general information from the management services component.</p>
<p><b>Parameter</b> Node operator facility</p> <p><b>Valid Values</b> Yes, No</p> <p><b>Default Value</b> No</p> <p><b>Description</b> This parameter enables or disables this APPN trace option. When enabled, this parameter informs the trace facility to include trace data about general information from the node operator facility component.</p>

## APPN Configuration Commands

Table 13. Configuration Parameter List - General Component Level Traces (continued)

Parameter Information
<p><b>Parameter</b> Path control</p> <p><b>Valid Values</b> Yes, No</p> <p><b>Default Value</b> No</p> <p><b>Description</b> This parameter enables or disables this APPN trace option. When enabled, this parameter informs the trace facility to include trace data about general information from the path control component.</p>
<p><b>Parameter</b> Problem determination services</p> <p><b>Valid Values</b> Yes, No</p> <p><b>Default Value</b> No</p> <p><b>Description</b> This parameter enables or disables this APPN trace option. When enabled, this parameter informs the trace facility to include trace data about general information from the problem determination component.</p>
<p><b>Parameter</b> Rapid transport protocol</p> <p><b>Valid Values</b> Yes, No</p> <p><b>Default Value</b> No</p> <p><b>Description</b> This parameter enables or disables this APPN trace option. When enabled, this parameter informs the trace facility to include trace data about general information from the rapid transport control component.</p>
<p><b>Parameter</b> Session connector manager</p> <p><b>Valid Values</b> Yes, No</p> <p><b>Default Value</b> No</p> <p><b>Description</b> This parameter enables or disables this APPN trace option. When enabled, this parameter informs the trace facility to include trace data about general information from the session connector manager component.</p>



## APPN Configuration Commands

Table 13. Configuration Parameter List - General Component Level Traces (continued)

Parameter Information
<p><b>Parameter</b> Session connector</p> <p><b>Valid Values</b> Yes, No</p> <p><b>Default Value</b> No</p> <p><b>Description</b> This parameter enables or disables this APPN trace option. When enabled, this parameter informs the trace facility to include trace data about general information from the session connector component.</p>
<p><b>Parameter</b> Session services</p> <p><b>Valid Values</b> Yes, No</p> <p><b>Default Value</b> No</p> <p><b>Description</b> This parameter enables or disables this APPN trace option. When enabled, this parameter informs the trace facility to include trace data about general information from the session services component.</p>
<p><b>Parameter</b> SNMP subagent</p> <p><b>Valid Values</b> Yes, No</p> <p><b>Default Value</b> No</p> <p><b>Description</b> This parameter enables or disables this APPN trace option. When enabled, this parameter informs the trace facility to include trace data about general information from the SNMP subagent component.</p>
<p><b>Parameter</b> TN3270E Server</p> <p><b>Valid Values</b> Yes, No</p> <p><b>Default Value</b> No</p> <p><b>Description</b> This parameter enables or disables this APPN trace option. When enabled, this parameter informs the trace facility to include trace data about general information from the TN3270E Server component.</p>

## APPN Configuration Commands

Table 13. Configuration Parameter List - General Component Level Traces (continued)

Parameter Information
<p><b>Parameter</b> Topology and routing services</p> <p><b>Valid Values</b> Yes, No</p> <p><b>Default Value</b> No</p> <p><b>Description</b> This parameter enables or disables this APPN trace option. When enabled, this parameter informs the trace facility to include trace data about general information from the topology and routing services component.</p>

Table 14. Configuration Parameter List - Miscellaneous Traces

Parameter Information
<p><b>Parameter</b> Data link control transmissions and receptions</p> <p><b>Valid Values</b> Yes, No</p> <p><b>Default Value</b> No</p> <p><b>Description</b> If this parameter is enabled, the APPN trace facility will trace all XIDs and PIUs transmitted and received by the APPN node.</p>
<p><b>Parameter</b> Filter the Data</p> <p><b>Valid Values</b> Yes, No</p> <p><b>Default Value</b> No</p> <p><b>Description</b> If this parameter is enabled, the APPN trace facility will filter the trace data according to the way you answer the following questions.</p>
<p><b>Parameter</b> Truncate the data</p> <p><b>Valid Values</b> Yes, No</p> <p><b>Default Value</b> No</p> <p><b>Description</b> If this parameter is enabled, the APPN trace facility will truncate the trace data. You will be asked to specify the <i>length to trace</i></p>

## APPN Configuration Commands

Table 14. Configuration Parameter List - Miscellaneous Traces (continued)

Parameter Information
<p><b>Parameter</b> Length to trace</p> <p><b>Valid Values</b> 1 - 3600</p> <p><b>Default Value</b> 100</p> <p><b>Description</b> This parameter specifies the number of bytes of trace data to accumulate.</p>
<p><b>Parameter</b> Trace Locates</p> <p><b>Valid Values</b> Yes, No</p> <p><b>Default Value</b> No</p> <p><b>Description</b> If this parameter is enabled, the APPN trace facility will filter the trace data according to locates.</p>
<p><b>Parameter</b> Trace TDUs</p> <p><b>Valid Values</b> Yes, No</p> <p><b>Default Value</b> No</p> <p><b>Description</b> If this parameter is enabled, the APPN trace facility will filter the trace data according to transmission data units.</p>
<p><b>Parameter</b> Trace route setups</p> <p><b>Valid Values</b> Yes, No</p> <p><b>Default Value</b> No</p> <p><b>Description</b> If this parameter is enabled, the APPN trace facility will filter the trace data according to route setups.</p>
<p><b>Parameter</b> Trace CP Capabilities</p> <p><b>Valid Values</b> Yes, No</p> <p><b>Default Value</b> No</p> <p><b>Description</b> If this parameter is enabled, the APPN trace facility will filter the trace data according to CP Capabilities.</p>

## APPN Configuration Commands

Table 14. Configuration Parameter List - Miscellaneous Traces (continued)

Parameter Information
<p><b>Parameter</b> Trace Session Control</p> <p><b>Valid Values</b> Yes, No</p> <p><b>Default Value</b> No</p> <p><b>Description</b> If this parameter is enabled, the APPN trace facility will filter the trace data according to session control.</p>
<p><b>Parameter</b> Trace XIDs</p> <p><b>Valid Values</b> Yes, No</p> <p><b>Default Value</b> No</p> <p><b>Description</b> If this parameter is enabled, the APPN trace facility will filter the trace data according to XIDs.</p>

### Syntax:

**set** management

You will be prompted to enter values for the following parameters. The parameter range will be shown in parentheses ( ). The parameter default will be shown in square brackets [ ].

Table 15. Configuration Parameter List - APPN Node Management

Parameter Information
<p><b>Parameter</b> Collect intermediate session information</p> <p><b>Valid Values</b> Yes, No</p> <p><b>Default Value</b> No</p> <p><b>Description</b> This parameter specifies whether the APPN node should collect data on intermediate sessions passing through this node (session counters and session characteristics). The data is captured in SNMP MIB variables for APPN.</p>

## APPN Configuration Commands

Table 15. Configuration Parameter List - APPN Node Management (continued)

Parameter Information
<p><b>Parameter</b> Save RSCV information for intermediate sessions</p> <p><b>Valid Values</b> Yes, No</p> <p><b>Default Value</b> No</p> <p><b>Description</b> This parameter specifies whether the APPN node should save the Route Selection control vector (RSCV) for an intermediate session. The data is captured in an associated SNMP MIB variable for APPN.</p> <p>The session RSCV is carried in the BIND request used to activate a session between two LUs. It describes the optimum route through an APPN network for a particular LU-LU session. The session RSCV contains the CP names and TG associated with each pair of adjacent nodes along a route from an origin node to a destination node.</p>
<p><b>Parameter</b> Create intermediate session records</p> <p><b>Valid Values</b> Yes, No</p> <p><b>Default Value</b> No</p> <p><b>Description</b> This parameter enables or disables the creation of data records for intermediate sessions passing through this node. The records contain information about session counters and session characteristics. RSCV information is also included in the data records if the Save RSCV information for intermediate sessions parameter is enabled.</p> <p>If this parameter is set to yes, the setting of <i>collect intermediate session information</i> is overridden.</p>
<p><b>Parameter</b> Record creation threshold</p> <p><b>Valid Values</b> 0 to 4 294 967, in 1 KB increments</p> <p><b>Default Value</b> 0</p> <p><b>Description</b> This parameter specifies a byte threshold for creating intermediate session records. When session data exceeds the value in this byte counter by an even multiple, a record is created.</p>

## APPN Configuration Commands

Table 15. Configuration Parameter List - APPN Node Management (continued)

Parameter Information
<p><b>Parameter</b> Held alert queue size</p> <p><b>Valid Values</b> 0 — 255</p> <p><b>Default Value</b> 10</p> <p><b>Description</b> This parameter sets the size of the configurable held alert queue. This queue is used to save APPN alerts prior to sending them to a focal point. If the queue overflows, the oldest alerts are discarded.</p>

Table 16. Configuration Parameter List - APPN ISR Recording Media

Parameter Information
<p><i>Memory Parameters</i></p> <p><b>Parameter</b> Memory (see table notes)</p> <p><b>Valid Values</b> Yes, No</p> <p><b>Default Value</b> No</p> <p><b>Description</b> This parameter enables or disables the collection of intermediate session data in the router's local memory.</p>
<p><b>Parameter</b> Maximum memory buffers</p> <p><b>Valid Values</b> 0 to 1</p> <p><b>Default Value</b> 1</p> <p><b>Description</b> This parameter specifies the number of buffers to be allocated in the router's local memory for storing intermediate session records.</p>
<p><b>Parameter</b> Maximum memory records per buffer</p> <p><b>Valid Values</b> 0 to 2000</p> <p><b>Default Value</b> 100</p> <p><b>Description</b> This parameter specifies the maximum number of intermediate session records that may be stored in the memory buffer on the router.</p>

## APPN Configuration Commands

Table 16. Configuration Parameter List - APPN ISR Recording Media (continued)

Parameter Information
<p><b>Parameter</b> Memory buffers full</p> <p><b>Valid Values</b> Stop recording (0), Wrap (1)</p> <p><b>Default Value</b> Stop recording (0)</p> <p><b>Description</b> This parameter specifies the action to take when the memory buffer allocated to store intermediate session records becomes full. Select <b>Stop recording</b> to instruct the router to discard any new intermediate session records. Select <b>Wrap</b> to allow new records to overwrite existing records in the buffer. The oldest records in the buffer are overwritten first.</p>
<p><b>Parameter</b> Memory record format</p> <p><b>Valid Values</b> ASCII (0), Binary (1)</p> <p><b>Default Value</b> ASCII (0)</p> <p><b>Description</b> This parameter specifies the format in which intermediate session records are to be stored in the router's local memory.</p>
<p><b>Parameter</b> Topology safe store</p> <p><b>Valid Values</b> Yes or No</p> <p><b>Default Value</b> No</p> <p><b>Description</b> This parameter specifies whether the topology data base is to be saved on the hardfile. This function is not supported if compact Flash memory is used. It can only be used when a hardfile is present.</p>
<p><b>Parameter</b> Time between database updates</p> <p><b>Valid Values</b> 60 — 1440 minutes</p> <p><b>Default Value</b> 60</p> <p><b>Description</b> This parameter sets the time in minutes between topology database updates.</p>

## APPN Configuration Commands

Table 16. Configuration Parameter List - APPN ISR Recording Media (continued)

Parameter Information
<b>Note:</b> <ul style="list-style-type: none"><li>• When you enable the collection of intermediate session records, the data associated with the records also is collected, by default, in SNMP</li><li>• MIB variables for APPN. The MIB variables are updated, in this case, whether or not the Collect intermediate session information parameter (in Table 15 on page 118) has been enabled.</li><li>• Intermediate session data can be stored in router memory.</li></ul>

## Add

Use the **add** command to add or update:

### Syntax:

**add** port

You will be prompted to enter values for the following parameters. The parameter range will be shown in parentheses ( ). The parameter default will be shown in square brackets [ ].

Table 17. Configuration Parameter List - Port Configuration

Parameter Information
<b>Parameter</b> Link type
<b>Valid Values</b> Ethernet (E) Token ring (T) DLSw (D) PPP (P) Frame relay (F) SDLC (S) X.25 (X) IP
<b>Default Value</b> None
<b>Description</b> This parameter specifies the type of link associated with this port.



## APPN Configuration Commands

Table 17. Configuration Parameter List - Port Configuration (continued)

Parameter Information
<p><b>Parameter</b> Interface number</p> <p><b>Valid Values</b> 0 to 65533</p> <p><b>Default Value</b> 0</p> <p><b>Description</b> This parameter defines the physical interface number of the hardware interface to which this device is attached.</p>
<p><b>Parameter</b> Port name</p> <p><b>Valid Values</b> A string of 1 to 8 characters, where the first character is alphabetic and the 2nd through 8th characters are alphanumeric.</p> <p><b>Default Value</b> A unique unqualified name that is automatically generated.</p> <p>The name will consist of:</p> <ul style="list-style-type: none"><li>• TR (token-ring)</li><li>• EN (Ethernet)</li><li>• DLS (DLSw)</li><li>• IP255</li><li>• FR (frame relay)</li><li>• X25 (X.25)</li><li>• SDLC (SDLC)</li><li>• PPP (point-to-point)</li><li>• IP</li></ul> <p>followed by the interface number.</p> <p>You can change the port name to a name of your choice.</p> <p><b>Description</b> This parameter specifies the name representing this port.</p>
<p><b>Parameter</b> Enable APPN routing on this port</p> <p><b>Valid Values</b> Yes, No</p> <p><b>Default Value</b> Yes</p> <p><b>Description</b> This parameter specifies whether APPN routing is to be enabled on this port.</p>

## APPN Configuration Commands

Table 17. Configuration Parameter List - Port Configuration (continued)

Parameter Information
<p><b>Parameter</b> Support multiple PU</p> <p><b>Valid Values</b> Yes, No</p> <p><b>Default Value</b> No</p> <p><b>Description</b> This parameter specifies whether the port will support multiple subarea.</p>
<p><b>Parameter</b> Service any node</p> <p><b>Valid Values</b> Yes No</p> <p><b>Default Value</b> Yes</p> <p><b>Description</b> This parameter specifies how the router network node responds to a request from another node to establish a connection over this port. When this parameter is enabled, the network node accepts any request it receives from another node to establish a connection. When this parameter is disabled, the network node accepts connection requests only from nodes that you explicitly define (via link station definitions). This option provides an added level of security for the router network node. <b>Note:</b> When you disable this parameter, a connection request from an adjacent node will be accepted only if the node's fully-qualified CP name parameter has been configured for a link station defined on this port.  When this parameter is enabled (the default), you may still want this network node to be able to initiate connections with specific nodes over this port.</p>
<p><b>Parameter</b> High-performance routing (HPR) supported</p> <p><b>Valid Values</b> Yes, No</p> <p><b>Default Value</b> Yes for token-ring, Ethernet, frame relay, and PPP ports.</p> <p><b>Description</b> This parameter indicates whether link stations on this port will support HPR. This value may be overridden on the link station definition.</p>

## APPN Configuration Commands

Table 17. Configuration Parameter List - Port Configuration (continued)

Parameter Information
<p><b>Parameter</b> IPv4 Precedence</p> <p><b>Valid Values</b> Yes or No</p> <p><b>Default Value</b> No</p> <p><b>Description</b> This parameter sets the IPv4 precedence value, which allows BRS precedence filtering of IPv4 encapsulated packets.</p>
<p><b>Parameter</b> Limited Resource ( PPP and FR over dial circuits only)</p> <p><b>Valid Values</b> Yes, No</p> <p><b>Default Value</b> If the dial circuit is <i>dial on demand</i>, the default is Yes. Otherwise, the default is No.</p> <p><b>Description</b> This parameter specifies whether link stations on this port are a limited resource. This value may be overridden on the link station definition.</p>
<p><b>Parameter</b> Support bridged formatted frames (Frame relay only)</p> <p><b>Valid Values</b> Yes, No</p> <p><b>Default Value</b> No</p> <p><b>Description</b> This parameter specifies whether the frame relay port will support bridged formatted frames.</p> <p>If you are configuring frame relay to support bridged format, you will also need to configure a boundary node identifier.</p>
<p><b>Parameter</b> Boundary node identifier (frame relay only)</p> <p><b>Valid Values</b> X'0000 0000 0001' to X'7FFF FFFF FFFF'</p> <p><b>Default Value</b> X'4FFF 0000 0000'</p> <p><b>Description</b> This parameter specifies the boundary node identifier MAC address. The router uses this MAC address to recognize that the frame is a frame relay bridged frame destined for APPN.</p>

## APPN Configuration Commands

Table 17. Configuration Parameter List - Port Configuration (continued)

Parameter Information
<p><b>Parameter</b> Subnet visit count</p> <p><b>Valid Values</b> 1 - 255</p> <p><b>Default Value</b> Default taken from the equivalent node level parameter</p> <p><b>Description</b> This parameter specifies this port's default for the maximum number of subnetworks that a multi-subnet session may traverse. <b>Note:</b> This question is asked only if the border node function is enabled on this node.</p>
<p><b>Parameter</b> Adjacent node subnet affiliation</p> <p><b>Valid Values</b></p> <ul style="list-style-type: none"><li>• 0 (native)</li><li>• 1 (non-native)</li><li>• 2 (negotiable)</li></ul> <p><b>Default Value</b> 2</p> <p><b>Description</b> This parameter specifies the default for all links through this port as to whether the adjacent node is in this node's native APPN subnetwork or in a non-native APPN subnetwork. A value of 2 instructs the node to negotiate at link activation time to determine whether the adjacent link station is native or non-native. <b>Note:</b> This question is asked only if the border node function is enabled on this node.</p>

Table 18. Configuration Parameter List - Port Definition

Parameter Information
<p><b>Parameter</b> Maximum BTU size</p>
<p><b>Valid Values</b> 768 to 1496 bytes for Ethernet 768 to 17745 bytes for token-ring 768 to 4096 bytes for IP 768 to 8136 bytes for Frame Relay 768 to 8132 bytes for frame relay over ISDN and V.25bis 768 to 4086 bytes for PPP 768 to 4082 bytes for PPP over ISDN and V.25bis X.25 will take value from network level 768 to 2048 bytes for all other ports</p>
<p><b>Default Value</b> 1289 bytes for Ethernet 2048 bytes for token-ring 1469 bytes for IP 2048 bytes for frame relay or PPP 2044 bytes for frame relay or PPP over ISDN and V.25bis 2048 bytes for SDLC X.25 will take value from network level</p>
<p><b>Description</b> This parameter specifies the number of bytes in the largest basic transmission unit (BTU) that can be processed (transmitted or received) by a link station defined on this port. <b>Note:</b> If a negotiable BIND with an RU size greater than 2048 is received, the device will normally choose a maximum RU size of 2048. If a non-negotiable BIND with an RU size greater than 2048 is received, the device will support the larger RU size up to a maximum size of 4096.</p>

## APPN Configuration Commands

Table 18. Configuration Parameter List - Port Definition (continued)

Parameter Information
<p><b>Parameter</b> Maximum number of link stations</p> <p><b>Valid Values</b> 1 to 127 for SDLC ports  1 to 239 for X.25 ports  1 to 976 for all other ports  (cannot be configured for PPP ports)</p> <p><b>Default Value</b> 1 for PPP ports (cannot be changed)  If SDLC is configured as multipoint and primary, then this parameter defaults to 127. Otherwise, it is set to 1 and is not configurable.  239 for X.25 ports  512 for all other ports</p> <p><b>Description</b> This parameter specifies the maximum number of link stations that will be allowed to use this port. This parameter allows the resources for the APPN node and this port to be constrained.</p>
<p><b>Parameter</b> Percent of link stations reserved for incoming calls (Ethernet, token-ring, FR, X.25 only)</p> <p><b>Valid Values</b> 0 to 100  The sum of the percent of link stations reserved for incoming calls and the percent of link stations reserved for outgoing calls cannot exceed 100%.</p> <p><b>Default Value</b> 0</p> <p><b>Description</b> This parameter specifies the percentage of the maximum number of link stations that will be reserved for incoming calls. Link stations that are not reserved for incoming or outgoing calls are available for either purpose on a demand basis.</p>

## APPN Configuration Commands

Table 18. Configuration Parameter List - Port Definition (continued)

Parameter Information
<p><b>Parameter</b> Percent of link stations reserved for outgoing calls</p> <p><b>Valid Values</b> 0 to 100</p> <p>The sum of the percent of link stations reserved for incoming calls and the percent of link stations reserved for outgoing calls cannot exceed 100%. If SDLC primary and multipoint, then valid value is 100.</p> <p><b>Default Value</b> 0 If SDLC primary and multipoint, then default value is 100.</p> <p><b>Description</b> This parameter specifies the percentage of the maximum number of link stations that will be reserved for outgoing calls. Fractions resulting from the computation are truncated. Link stations that are not reserved for incoming or outgoing calls are available for either purpose on a demand basis.</p>
<p><b>Parameter</b> UDP port number for XID exchange</p> <p><b>Valid Values</b> 1024 to 65535</p> <p><b>Default Value</b> 11000</p> <p><b>Description</b> This parameter specifies the UDP port number to be used for XID exchange and is used during IP port definition. This port number must be the same as the one defined on other devices in the network.</p>
<p><b>Parameter</b> UDP port number for network priority traffic</p> <p><b>Valid Values</b> 1024 to 65535</p> <p><b>Default Value</b> 11001</p> <p><b>Description</b> This parameter specifies the UDP port number to be used for network priority traffic.</p>
<p><b>Parameter</b> UDP port number for high priority traffic</p> <p><b>Valid Values</b> 1024 to 65535</p> <p><b>Default Value</b> 11002</p> <p><b>Description</b> This parameter specifies the UDP port number to be used for high priority traffic.</p>

## APPN Configuration Commands

Table 18. Configuration Parameter List - Port Definition (continued)

Parameter Information
<p><b>Parameter</b> UDP port number for medium priority traffic</p> <p><b>Valid Values</b> 1024 to 65535</p> <p><b>Default Value</b> 11003</p> <p><b>Description</b> This parameter specifies the UDP port number to be used for medium priority traffic.</p>
<p><b>Parameter</b> UDP port number for low priority traffic</p> <p><b>Valid Values</b> 1024 to 65535</p> <p><b>Default Value</b> 11004</p> <p><b>Description</b> This parameter specifies the UDP port number to be used for low priority traffic.</p>
<p><b>Parameter</b> IP network type</p> <p><b>Valid Values</b> Campus or Widearea</p> <p><b>Default Value</b> Widearea</p> <p><b>Description</b> This parameter specifies the IP network type.</p>
<p><b>Parameter</b> Local APPN SAP address</p> <p><b>Valid Values</b> Multiples of four in the hexadecimal range X'04' to X'EC'</p> <p><b>Default Value</b> X'04'</p> <p><b>Description</b> This parameter specifies the local SAP address to be used for communicating with APPN link stations defined on this port.</p>



## APPN Configuration Commands

Table 18. Configuration Parameter List - Port Definition (continued)

Parameter Information
<p><b>Parameter</b> Local HPR SAP address (Ethernet and token-ring only)</p> <p><b>Valid Values</b> Multiples of four in the hexadecimal range X'04' to X'EC'</p> <p><b>Default Value</b> X'C8'</p> <p><b>Description</b> This parameter indicates the local service access point to be used for communicating with HPR link stations defined on this port.</p>
<p><b>Parameter</b> Branch uplink</p> <p><b>Valid Values</b> Yes or No</p> <p><b>Default Value</b> No</p> <p><b>Description</b> This parameter indicates whether the default for link stations using this port will be uplink or downlink. If <b>yes</b> is specified, link stations using this port will default <b>Branch uplink</b> to <b>yes</b>.</p> <p><b>Notes:</b></p> <ol style="list-style-type: none"><li>1. This question is asked only if the node-level parameter <b>Enabled Branch Extender</b> is <b>yes</b>.</li><li>2. If <b>Branch uplink</b> is <b>yes</b>, the Branch Extender will present its end node appearance to this link station. Otherwise, the Branch Extender will present its network node appearance.</li><li>3. Typically, <b>Branch uplink</b> is <b>yes</b> for WAN-attached network nodes and is <b>no</b> for LAN-attached end nodes.</li></ol>

## APPN Configuration Commands

Table 19. Configuration Parameter List - Port Default TG Characteristics

Parameter Information	
<b>Parameter</b>	Cost per connect time
<b>Valid Values</b>	0 to 255
<b>Default Value</b>	<p>For IP: 0 for Campus and WAN</p> <p>For all other: 0</p>
<b>Description</b>	<p>This parameter specifies the cost per connect time TG characteristic for all link stations on this port.</p> <p>The cost per connect time TG characteristic expresses the relative cost of maintaining a connection over the associated TG. The units are user-defined and are typically based on the applicable tariffs of the transmission facility being used. The assigned values should reflect the actual expense of maintaining a connection over the TG relative to all other TGs in the network. A value of zero means that connections over the TG may be made at no additional cost (as in the case of many non-switched facilities). Higher values represent higher costs.</p>
<b>Parameter</b>	Cost per byte
<b>Valid Values</b>	0 to 255
<b>Default Value</b>	<p>For IP: 0 for Campus and WAN</p> <p>For all other: 0</p>
<b>Description</b>	<p>This parameter specifies the cost per byte TG characteristic for all link stations defined on this port.</p> <p>The cost per byte TG characteristic expresses the relative cost of transmitting a byte over the associated TG. The units are user-defined and the assigned value should reflect the actual expenses incurred for transmitting over the TG relative to all other TGs in the network. A value of zero means that bytes may be transmitted over the TG at no additional cost. Higher values represent higher costs.</p>

Table 19. Configuration Parameter List - Port Default TG Characteristics (continued)

<b>Parameter Information</b>	
<b>Parameter</b>	Security
<b>Valid Values</b>	<p><b>Nonsecure</b>      all else (for example, satellite-connected, or located in a nonsecure country).</p> <p><b>Public switched network</b> secure in the sense that route is not predetermined</p> <p><b>Underground cable</b> located in secure country (as determined by the network administrator)</p> <p><b>Secure conduit</b>    Not guarded, (for example, pressurized pipe)</p> <p><b>Guarded conduit</b> protected against physical tapping</p> <p><b>Encrypted</b>        link-level encryption is provided</p> <p><b>Guarded radiation</b> guarded conduit containing the transmission medium; protected against physical and radiation tapping</p>
<b>Default Value</b>	<p>For IP:</p> <p><b>Campus</b>            Nonsecure</p> <p><b>WAN</b>                Public switched network</p> <p>For all other: Nonsecure</p>
<b>Description</b>	<p>This parameter specifies the security TG characteristic for all link stations defined on this port. The security TG characteristic indicates the level of security protection associated with the TG. If security attributes other than the architecturally-defined ones are needed, one of the user-defined TG characteristics may be used to specify additional values.</p>

## APPN Configuration Commands

Table 19. Configuration Parameter List - Port Default TG Characteristics (continued)

Parameter Information
<b>Parameter</b> Propagation delay
<b>Valid Values</b>
<b>Minimum LAN</b> less than 480 microseconds
<b>Telephone</b> between .48 and 49.152 milliseconds
<b>Packet switched</b> between 49.152 and 245.76 milliseconds
<b>Satellite</b> greater than 245.76 milliseconds maximum
<b>Default Value</b>
For IP:
<b>Campus</b> Telephone
<b>WAN</b> Packet switched
<b>Description</b> This parameter specifies the propagation delay TG characteristic for all link stations defined on this port. The propagation delay TG characteristic specifies the approximate range for the length of time that it takes for a signal to propagate from one end of the TG to the other.

Table 19. Configuration Parameter List - Port Default TG Characteristics (continued)

<b>Parameter Information</b>
<p><b>Parameter</b> Effective capacity</p> <p><b>Valid Values</b> 2 hexadecimal digits in the range X'00' to X'FF'</p> <p><b>Default Value</b>            FR=X'45' (64 Kbps)            PPP=X'45' (64 Kbps)            DLSw=X'75' (4 Mbps)            SDLC=X'45' (64 Kbps)            X.25=X'45' (64 Kbps)            Token ring: X'75' when minimum is 4 Mbps            Token ring: X'85' when minimum is 16 Mbps            Ethernet/802.3 ports: X'80' for 10 Mbps            100Mbps Ethernet: X'9A'</p> <p>For IP:            Campus: X'75'            WAN: X'43'</p> <p><b>Description</b>            This parameter specifies the effective capacity TG characteristic for all associated connections (TGs) on this port.</p> <p>This parameter specifies the maximum bit transmission rate for both physical links and logical links. Note that the effective capacity for a logical link may be less than the physical link speed. The rate is represented in COS files as a floating-point number encoded in a single byte with units of 300 bps. The effective capacity is encoded as a single-byte representation. The values X'00' and X'FF' are special cases used to denote minimum and maximum capacities. The range of the encoding is very large; however, only 256 values in the range may be specified.</p> <p>This parameter provides the default value for the Effective capacity parameter on the Modify TG Characteristics Command Line option. The Modify TG Characteristics Command Line option enables you to override the .* default values assigned to TG characteristics on the individual link stations you define.</p>

## APPN Configuration Commands

Table 19. Configuration Parameter List - Port Default TG Characteristics (continued)

Parameter Information
<p><b>Parameter</b> First user-defined TG characteristic</p> <p><b>Valid Values</b> 0 to 255</p> <p><b>Default Value</b> 128</p> <p><b>Description</b> This parameter specifies the first user-defined TG characteristic for all link stations defined on this port.</p> <p>The first user-defined TG characteristic specifies the first of three additional characteristics that users can define to describe the TGs in a network. The default value of 128 allows a subset of TGs to be defined as more or less desirable than the rest without defining values for all TGs.</p>
<p><b>Parameter</b> Second user-defined TG characteristic</p> <p><b>Valid Values</b> 0 to 255</p> <p><b>Default Value</b> 128</p> <p><b>Description</b> This parameter specifies the second user-defined TG characteristic for all link stations defined on this port.</p> <p>The second user-defined TG characteristic specifies the second of three additional characteristics that users can define to describe the TGs in a network.</p>
<p><b>Parameter</b> Third user-defined TG characteristic</p> <p><b>Valid Values</b> 0 to 255</p> <p><b>Default Value</b> 128</p> <p><b>Description</b> This parameter specifies the third user-defined TG characteristic for all link stations defined on this port.</p> <p>The third user-defined TG characteristic specifies the third of three additional characteristics that users can define to describe the TGs in a network.</p>

## APPN Configuration Commands

Table 20. Configuration Parameter List - Port default LLC Characteristics

Parameter Information
<p><b>Parameter</b> Remote APPN SAP</p> <p><b>Valid Values</b> Multiples of four in the hexadecimal range of X'04' to X'EC'</p> <p><b>Default Value</b> X'04'</p> <p><b>Description</b> This parameter specifies the SAP associated with an adjacent node's APPN link station.</p>
<p><b>Parameter</b> Maximum number of outstanding I-format LPDUs (TW)</p> <p><b>Valid Values</b> 1 to 127</p> <p><b>Default Value</b> 26</p> <p><b>Description</b> This parameter specifies the LLC maximum number of outstanding I-format LPDUs (TW) for all link stations on this port.</p> <p>The maximum number of outstanding I-format LPDUs defines the transmit Command Line option (TW) which is the maximum number of sequentially numbered I-format LPDUs that the link station may have unacknowledged at any given time.</p>
<p><b>Parameter</b> Receive window size</p> <p><b>Valid Values</b> 1 to 127</p> <p><b>Default Value</b> 26</p> <p><b>Description</b> This parameter specifies the LLC receive Command Line option size (RW) for all link stations on this port.</p> <p>The RW parameter specifies the maximum number of unacknowledged sequentially numbered I-format LPDUs that the link station can receive from the remote link station. RW is advertised in SNA XID frames and IEEE 802.2 XID frames. The XID receiver should set its effective TW to a value less than or equal to the value of the received RW to avoid overruns.</p>

## APPN Configuration Commands

Table 20. Configuration Parameter List - Port default LLC Characteristics (continued)

Parameter Information
<p><b>Parameter</b> Inactivity timer (Ti)</p> <p><b>Valid Values</b> 1 to 254 seconds</p> <p><b>Default Value</b> 30 seconds</p> <p><b>Description</b> This parameter specifies the LLC inactivity timer (Ti) for all link stations on this port.</p> <p>An LLC link station uses Ti to detect an inoperative condition in either the remote link station or in the transmission media. If an LPDU is not received in the time interval specified by Ti, an S-format command LPDU with the poll bit set is transmitted to solicit remote link station status. Recovery is then based on the reply timer (T1).</p>
<p><b>Parameter</b> Reply timer (T1)</p> <p><b>Valid Values</b> 1 to 254 half-seconds</p> <p><b>Default Value</b> 2 half-seconds</p> <p><b>Description</b> This parameter specifies the LLC reply timer (T1) for all link stations on this port.</p> <p>An LLC link station uses T1 to detect a failure to receive a required acknowledgment or response from the remote link station. When T1 expires, the link station sends an S-format command link layer protocol data unit (LPDU) with the poll bit set to solicit remote link station status or any U-format command LPDUs that have not been responded to. The duration of T1 should take into account any delays introduced by underlying layers.</p>
<p><b>Parameter</b> Maximum number of retransmissions (N2)</p> <p><b>Valid Values</b> 1 to 254</p> <p><b>Default Value</b> 8</p> <p><b>Description</b> This parameter specifies the maximum number of retransmissions (N2) for all link stations on this port.</p> <p>The N2 parameter specifies the maximum number of times an LPDU will be retransmitted following expiration of the reply timer (T1).</p>



## APPN Configuration Commands

Table 20. Configuration Parameter List - Port default LLC Characteristics (continued)

Parameter Information
<p><b>Parameter</b> Receive acknowledgment timer (T2)</p> <p><b>Valid Values</b> 1 to 254 half-seconds</p> <p><b>Default Value</b> 1 half-second</p> <p><b>Description</b> This parameter specifies the LLC receiver acknowledgment timer (T2) for all link stations on this port.</p> <p>The T2 parameter may be used with the N3 counter to reduce acknowledgment traffic. A link station uses T2 to delay the sending of an acknowledgment for a received I-format LPDU. T2 is started when an I-format LPDU is received, and reset when an acknowledgment is sent in an I-format or S-format LPDU. If T2 expires, the link station must send an acknowledgment as soon as possible. The value of T2 must be less than that of T1, to ensure that the remote link station will receive the delayed acknowledgment before its T1 expires.</p>
<p><b>Parameter</b> Acknowledgments needed to increment working window</p> <p><b>Valid Values</b> 0 to 127</p> <p><b>Default Value</b> 1</p> <p><b>Description</b> When the working window (Ww) is not equal to the Maximum Transmit Window Size (Tw), this parameter is the number of transmitted I-format LPDUs that must be acknowledged before the working window can be incremented (by 1). When congestion is detected, by the loss of I-format LPDUs, Ww is set to 1.</p>

Table 21. Configuration Parameter List - HPR Override Defaults

Parameter Information
<p><b>Parameter</b> Inactivity timer override for HPR (HPR Ti)</p> <p><b>Valid Values</b> 1 to 254 seconds</p> <p><b>Default Value</b> 2 seconds</p> <p><b>Description</b> This parameter specifies the LLC inactivity timer (HPR Ti) that is to be used for all link stations on this port supporting HPR when the HPR supported parameter is enabled on this port. This default overrides the value of the default LLC inactivity timer (Ti) parameter specified on the default LLC characteristics parameter.</p>

## APPN Configuration Commands

Table 21. Configuration Parameter List - HPR Override Defaults (continued)

Parameter Information
<p><b>Parameter</b> Reply timer override for HPR (HPR T1)</p> <p><b>Valid Values</b> 1 to 254 half-seconds</p> <p><b>Default Value</b> 2 half-seconds</p> <p><b>Description</b> This parameter specifies the LLC reply timer (HPR T1) that is to be used for all link stations on this port supporting HPR when the HPR supported parameter is enabled on this port. This default overrides the value of the default LLC reply timer (T1) parameter specified on the default LLC characteristics parameter.</p>
<p><b>Parameter</b> Maximum number of retransmissions for HPR (HPR N2)</p> <p><b>Valid Values</b> 1 to 254</p> <p><b>Default Value</b> 3</p> <p><b>Description</b> This parameter specifies the LLC maximum number of retransmissions (HPR N2) that is to be used for all link stations on this port supporting HPR when the HPR supported parameter is enabled on this port. This default overrides the value of the default LLC maximum number of retransmissions (N2) parameter specified on the default LLC Characteristics parameter.</p>

### Syntax:

**add** link-station

You will be prompted to enter values for the following parameters. The parameter range will be shown in parentheses ( ). The parameter default will be shown in square brackets [ ].

Table 22. Configuration Parameter List - Link Station - Detail

Parameter Information
<p><b>Parameter</b> Does link support APPN function</p> <p><b>Valid Values</b> Yes or No</p> <p><b>Default Value</b> Yes</p> <p><b>Description</b> This parameter specifies whether this link station will support APPN function.</p> <p>If the answer is <i>no</i>, questions concerning CP-CP sessions, security, encryption, CP name, adjacent node type, branch extender, and extended border node will not be asked and all of these functions will be disabled. Also, HPR will be disabled and no HPR questions will be asked.</p>

Table 22. Configuration Parameter List - Link Station - Detail (continued)

Parameter Information
<p><b>Parameter</b> Link station name (required)</p> <p><b>Valid Values</b> A string of 1 to 8 characters :</p> <ul style="list-style-type: none"> <li>• First character: A to Z</li> <li>• Second to eighth characters: A to Z, 0 to 9</li> </ul> <p><b>Default Value</b> None</p> <p><b>Description</b> This parameter specifies the name of a link station that represents the TG (link) between the router network node and the adjacent node. The link station name must be unique within this network node.</p>
<p><b>Parameter</b> Port name</p> <p><b>Valid Values</b> A unique unqualified name that is automatically generated.</p> <p>The name will consist of:</p> <ul style="list-style-type: none"> <li>• TR (token-ring)</li> <li>• EN (Ethernet)</li> <li>• DLS (DLSw)</li> <li>• FR (frame relay)</li> <li>• X25 (X.25)</li> <li>• SDLC (SDLC)</li> <li>• PPP (point-to-point)</li> <li>• IP</li> </ul> <p>followed by the interface number.</p> <p><b>Default Value</b> The name of the port that this link station is defined on.</p> <p><b>Description</b> This parameter specifies the name representing the port this link station is defined on. The port must already have been configured for APPN.</p>

## APPN Configuration Commands

Table 22. Configuration Parameter List - Link Station - Detail (continued)

Parameter Information
<p><b>Parameter</b> Link type (X.25 only)</p> <p>If <i>limited resource</i> = yes is configured for this link station, then the link type parameter defaults to a value of 1 (SVC) and is not configurable.</p> <p><b>Valid Values</b> If PVC, then specify a logical channel number in the range of 1 - 4095 If SVC, then specify a DTE address that is variable length up to 15 digits</p> <p><b>Default Value</b> 0, unless it is a limited resource.</p> <p><b>Description</b> This parameter specifies whether the X.25 link is a PVC or SVC.</p>
<p><b>Parameter</b> MAC address of adjacent node (required) (Ethernet, token-ring, DLSw, FR bridged format only)</p> <p><b>Valid Values</b> Token-ring and DLSw ports: • 12 hexadecimal digits in the range X'000000000001' to X'7FFFFFFFFFFF' Ethernet/802.3 ports: • 12 hexadecimal digits in the form X'xyxxxxxxxx' where:     x is any hexadecimal digit     y is a hexadecimal digit in the set {0, 2, 4, 6, 8, A, C, E}</p> <p><b>Default Value</b> None</p> <p><b>Description</b> This parameter specifies the medium access control (MAC) layer address of the adjacent node. Different formats are used for token-ring and Ethernet/802.3.</p> <p>Token-ring and DLSw ports: The MAC address is specified in noncanonical form. In the noncanonical address format, the bit within each octet that is to be transmitted first is represented as the most significant bit.</p> <p>Ethernet/802.3 ports: The MAC address is specified in canonical form. In the canonical address format, the bit within each octet that is to be transmitted first is represented as the least significant bit.</p>

## APPN Configuration Commands

Table 22. Configuration Parameter List - Link Station - Detail (continued)

Parameter Information
<p><b>Parameter</b> IP address of adjacent node</p> <p><b>Valid Values</b> Any valid IP address</p> <p><b>Default Value</b> none</p> <p><b>Description</b> Each link on the HPR/IP port must have a unique destination IP address.</p>
<p><b>Parameter</b> Adjacent node type</p> <p><b>Valid Values</b> APPN network node, APPN end node, LEN end node</p> <p><b>Default Value</b> APPN network node</p> <p><b>Description</b> This parameter identifies whether the adjacent node is an APPN node, a low-entry networking (LEN) end node.</p> <p>When <i>APPN end node</i> is selected and <i>Limited resource</i> is No, APPN changes the adjacent node type internally to <i>learn</i> and will work with any node type.</p> <p>When <i>APPN end node</i> is selected and <i>Limited resource</i> is Yes, the adjacent node type is unchanged.</p> <p>When you select <i>LEN end node</i>, the fully-qualified control point name parameter is a required parameter. If this network node is communicating with the IBM Virtual Telecommunications Access Method (VTAM) product through the LEN node, and the LEN node is not a T2.1 node or does not have an explicitly defined control point (CP) name, then the router network node's XID number for the Subarea connection parameter also must be specified to establish a connection.</p> <p><b>Note:</b> <i>LEN end node</i> is not a valid node type for HPR/IP interface.</p>

## APPN Configuration Commands

Table 22. Configuration Parameter List - Link Station - Detail (continued)

Parameter Information
<p><b>Parameter</b> fully-qualified CP name of adjacent node</p> <p><b>Valid Values</b> A string of up to 17 characters in the form of <i>netID.CPname</i>, where:</p> <ul style="list-style-type: none"><li>• <i>netID</i> is a network ID from 1 to 8 characters</li><li>• <i>CPname</i> is a control point name from 1 to 8 characters</li></ul> <p>Each name must conform to the following rules:</p> <ul style="list-style-type: none"><li>• First character: A to Z</li><li>• Second to eighth characters: A to Z, 0 to 9</li></ul> <p><b>Note:</b> An existing fully-qualified CP name, using the special characters @, \$, and from the character set A, continues to be supported; however, these characters should not be used for new CP names.</p> <p><b>Default Value</b> None</p> <p><b>Description</b> This parameter specifies the fully-qualified CP name of the adjacent node. For the cases where this parameter is not required, the adjacent node's CP name may be learned dynamically during XID exchange; however, if a CP name is specified, it must match the adjacent node's definition for the link to be successfully activated.</p> <p><b>Note:</b> This parameter is required when any of the following occur:</p> <ul style="list-style-type: none"><li>• The <i>Service any node</i> parameter is set to Disable.</li><li>• The <i>Adjacent node type</i> parameter is set to LEN end node.</li><li>• The <i>CP-CP session level security</i> parameter is set to Enable.</li><li>• The link is a limited resource.</li></ul>
<p><b>Parameter</b> Activate link automatically</p> <p>If limited resource, then this parameter is set to No and is not configurable.</p> <p><b>Valid Values</b> Yes, No</p> <p><b>Default Value</b> Yes</p> <p><b>Description</b> When this parameter is enabled, the router network node automatically activates the link to the adjacent node and initiates a connection.</p>

## APPN Configuration Commands

Table 22. Configuration Parameter List - Link Station - Detail (continued)

Parameter Information
<p><b>Parameter</b> Allow CP-CP sessions on this link</p> <p><b>Valid Values</b> Yes, No</p> <p><b>Default Value</b> Yes, if adjacent node type is APPN network node or APPN end node. No for all other adjacent node types</p> <p><b>Description</b> This parameter specifies whether sessions between control points are to be activated over this link station.</p> <p>This parameter allows control of CP-CP session establishment between adjacent network nodes so that the overhead associated with topology database updates (TDUs) may be constrained.</p> <p><b>Note:</b> Every APPN network node must have at least one CP-CP session established to another APPN network node in order to maintain the minimum connectivity necessary to update the topology database. In addition, more than minimum connectivity could be desired to eliminate single points of failure and to improve network dynamics.</p>
<p><b>Parameter</b> CP-CP session level security</p> <p><b>Valid Values</b> Yes, No</p> <p><b>Default Value</b> No</p> <p><b>Description</b> This parameter specifies whether session level security is enforced for CP-CP sessions established over this link station. When session level security is enabled, encrypted data is exchanged and compared during the BIND flows (which includes the BIND, the BIND response, and an FMH-12 Security RU). To successfully establish a CP-CP session with session level security enabled, both partners must be configured with the same encryption key. Currently, session level security support is limited to the basic LU-LU verification protocol.</p>
<p><b>Parameter</b> Encryption key</p> <p><b>Valid Values</b> Up to 16 hexadecimal digits. If fewer than 16 digits are specified, the value is padded on the right with zeros.</p> <p><b>Default Value</b> None</p> <p><b>Description</b> This parameter is used to encrypt data exchanged during BIND flows. Both partners must be configured with the same key to establish a CP-CP session.</p>

## APPN Configuration Commands

Table 22. Configuration Parameter List - Link Station - Detail (continued)

Parameter Information
<p><b>Parameter</b> Use enhanced session security (If security is enabled)</p> <p><b>Valid Values</b> Yes, No</p> <p><b>Default Value</b> No</p>
<p><b>Parameter</b> High-performance routing (HPR) supported</p> <p><b>Valid Values</b> Yes, No</p> <p><b>Default Value</b> APPN network node, APPN end node or LEN end node: the value specified in the default HPR supported parameter for this port All other adjacent node types: No</p> <p><b>Description</b> This parameter indicates whether this link station supports HPR. The user should disable HPR support if the underlying link is unreliable. An HPR connection will not be established unless both link stations advertise HPR support during XID exchange.</p>
<p><b>Parameter</b> DLCI number for link (frame relay only)</p> <p><b>Valid Values</b> 16 to 1007</p> <p><b>Default Value</b> 16</p> <p><b>Description</b> The DLCI parameter identifies the frame-relay logical data link connection with the adjacent node.</p>
<p><b>Parameter</b> Station address of adjacent node (SDLC only)</p> <p><b>Valid Values</b> Address in the range of (1 - FE)</p> <p><b>Default Value</b> C1</p> <p><b>Description</b> This parameter specifies the address of the adjacent node.</p>



## APPN Configuration Commands

Table 22. Configuration Parameter List - Link Station - Detail (continued)

Parameter Information
<p><b>Parameter</b> Limited Resource (PPP, X.25 FR over dial circuits)</p> <p><b>Valid Values</b> Yes, or No</p> <p><b>Default Value</b> No</p> <p>If the <i>link type</i> is PPP or FR, the default will be taken from the <i>limited resource</i> parameter for the associated port.</p> <p><b>Description</b> This parameter specifies whether the TG for this link station is a limited resource. If you answer <i>yes</i>, then the <b>Virtual Channel Type</b> is <i>SVC</i>.</p>
<p><b>Parameter</b> Branch Uplink</p> <p><b>Valid Values</b> Yes or No</p> <p><b>Default Value</b> The value specified for <b>Branch Uplink</b> on the port.</p> <p><b>Description</b> This parameter indicates whether this link will be a Branch uplink (to WAN) or Branch downlink (to LAN).</p> <p>This question is asked only if <b>Enabled Branch Extender</b> has been set to <i>yes</i> and if this link station is not a network node. If <b>Enabled Branch Extender</b> has been set to <i>yes</i> and this link station is a network node, then <b>Branch Uplink</b> defaults to <i>yes</i></p>
<p><b>Parameter</b> Is uplink to another Branch Extender node</p> <p><b>Valid Values</b> Yes or No</p> <p><b>Default Value</b> No</p> <p><b>Description</b> This parameter indicates whether or not the adjacent node has the Branch Extender function enabled.</p> <p>This question is asked only if <b>Branch Extender</b> is enabled on this node, this is an uplink, and the uplink is a limited resource.</p>

## APPN Configuration Commands

Table 22. Configuration Parameter List - Link Station - Detail (continued)

Parameter Information
<p><b>Parameter</b> Preferred Network Node Server</p> <p><b>Valid Values</b> Yes or No</p> <p><b>Default Value</b> No</p> <p><b>Description</b> This parameter indicates whether this uplink is to a network node server that is to be used as the network node server for the node supporting Branch Extender function and acting as an end node. If <i>yes</i> is specified, this uplink will be used as the network node server for this node.</p> <p>This question will be asked only if:</p> <ul style="list-style-type: none"> <li>• <b>Enabled Branch Extender</b> is <i>yes</i>,</li> <li>• This station is a network node,</li> <li>• <b>Branch Uplink</b> is <i>yes</i>, and</li> <li>• CP-CP sessions are supported on this link.</li> </ul>
<p><b>Parameter</b> TG Number</p> <p><b>Valid Values</b> If <i>limited resource</i> is Yes, valid values are 1 - 20. If <i>limited resource</i> is No and <i>link type</i> is X.25 SVC, valid values are 0 - 20.</p> <p>Otherwise, valid values are 0 - 20.</p> <p><b>Default Value</b> If <i>limited resource</i> is Yes, default is 1. If <i>limited resource</i> is No, default is 0.</p> <p>Otherwise, default value is 0.</p> <p><b>Description</b> This parameter uniquely identifies a TG between adjacent nodes.</p>
<p><b>Parameter</b> Solicit SSCP session</p> <p><b>Valid Values</b> Yes or No</p> <p><b>Default Value</b> No</p> <p>If the <b>link station name</b> is the same as the <b>CP name</b>, then the default is <i>yes</i>.</p> <p><b>Description</b> This parameter indicates whether this link is to solicit SSCP sessions.</p>

## APPN Configuration Commands

Table 22. Configuration Parameter List - Link Station - Detail (continued)

Parameter Information
<p><b>Parameter</b> Local Node ID</p> <p><b>Valid Values</b> 5 hexadecimal digits</p> <p><b>Default Value</b> X'00000'</p> <p><b>Description</b> This parameter specifies the local node identifier. This question is asked only if <b>solicit sscp session</b> is yes. The local node id must be unique.</p>
<p><b>Parameter</b> Local SAP address</p> <p><b>Valid Values</b> Any valid SAP address between X'04' and X'EC'.</p> <p><b>Default Value</b> Value taken from port</p> <p><b>Description</b> This parameter specifies local SAP address.</p> <p><b>Notes:</b></p> <ol style="list-style-type: none"> <li>1. This question is displayed only if there are multiple PUs defined on the port.</li> <li>2. If the local SAP address is not the main local SAP address on the port,</li> <li>3. the port name and SAP name will display in monitoring and SNMP display output.</li> </ol>
<p><b>Parameter</b> Subnet visit count</p> <p><b>Valid Values</b> 1 - 255</p> <p><b>Default Value</b> Default taken from the equivalent port level parameter</p> <p><b>Description</b> This parameter specifies the default for the maximum number of subnetworks that a multi-subnet session may traverse.</p> <p><b>Note:</b> This question is asked only if the border node function is enabled on this node.</p>

## APPN Configuration Commands

Table 22. Configuration Parameter List - Link Station - Detail (continued)

Parameter Information
<p><b>Parameter</b> Adjacent node subnet affiliation</p> <p><b>Valid Values</b> 0 (native)  1 (non-native)  2 (negotiable)</p> <p><b>Default Value</b> Default is taken from the equivalent port level parameter</p> <p><b>Description</b> This parameter specifies whether the adjacent node is in this node's native APPN subnetwork or in a non-native APPN subnetwork. A value of 2 instructs the node to negotiate at link activation time to determine whether the adjacent link station is native or non-native. <b>Note:</b> This question is asked only if the border node function is enabled on this node.</p>

Table 23. Configuration Parameter List - Modify TG Characteristics

Parameter Information
<p><b>Parameter</b> Cost per connect time</p> <p><b>Valid Values</b> 0 to 255</p> <p><b>Default Value</b> Default value is taken from the associated port parameter.</p> <p><b>Description</b> This parameter expresses the relative cost of maintaining a connection over the associated TG. The units are user-defined and are typically based on the applicable tariffs of the transmission facility being used. The assigned values should reflect the actual expense of maintaining a connection over the TG relative to all other TGs in the network. A value of zero means that connections over the TG may be made at no additional cost (as in the case of many non-switched facilities). Higher values represent higher costs.</p>
<p><b>Parameter</b> Cost per byte</p> <p><b>Valid Values</b> 0 to 255</p> <p><b>Default Value</b> Default value is taken from the associated port parameter.</p> <p><b>Description</b> This parameter expresses the relative cost of transmitting a byte over the associated TG. The units are user-defined and the assigned value should reflect the actual expenses incurred for transmitting over the TG relative to all other TGs in the network. A value of zero means that bytes may be transmitted over the TG at no additional cost. Higher values represent higher costs.</p>

## APPN Configuration Commands

Table 23. Configuration Parameter List - Modify TG Characteristics (continued)

Parameter Information
<p><b>Parameter</b> Security</p> <p><b>Valid Values</b></p> <ul style="list-style-type: none"><li>• Nonsecure - all else (for example, satellite-connected, or located in a nonsecure country).</li><li>• Public switched network - secure in the sense that route is not predetermined.</li><li>• Underground cable - located in secure country (as determined by the network administrator).</li><li>• Secure conduit - Not guarded, (for example, pressurized pipe).</li><li>• Guarded conduit - protected against physical tapping.</li><li>• Encrypted - link-level encryption is provided.</li><li>• Guarded radiation - guarded conduit containing the transmission medium; protected against physical and radiation tapping.</li></ul> <p><b>Default Value</b> Default value is taken from the associated port parameter.</p> <p><b>Description</b> This parameter indicates the level of security protection associated with the TG. If security attributes other than the architecturally-defined ones are needed, one of the user-defined TG characteristics may be used to specify additional values.</p>
<p><b>Parameter</b> Propagation delay</p> <p><b>Valid Values</b></p> <p>Minimum LAN – less than 480 microseconds Telephone – between .48 and 49.152 milliseconds Packet switched - between 49.152 and 245.76 milliseconds Satellite - greater than 245.76 milliseconds Maximum</p> <p><b>Default Value</b> Default value is taken from the associated port parameter.</p> <p><b>Description</b> This parameter specifies the approximate range for the length of time that it takes for a signal to propagate from one end of the TG to the other.</p>

## APPN Configuration Commands

Table 23. Configuration Parameter List - Modify TG Characteristics (continued)

Parameter Information
<p><b>Parameter</b> Effective capacity</p> <p><b>Valid Values</b> 2 hexadecimal digits in the range X'00' to X'FF'</p> <p><b>Default Value</b> Default value is taken from the associated port parameter.</p> <p><b>Description</b> This parameter specifies the maximum bit transmission rate for both physical links and logical links. Note that the effective capacity for a logical link may be less than the physical link speed.</p> <p>The effective capacity is encoded as a single-byte representation. The values X'00' and X'FF' are special cases used to denote minimum and maximum capacities. The range of the encoding is very large; however, only 256 values in the range may be specified.</p>
<p><b>Parameter</b> First user-defined TG characteristic</p> <p><b>Valid Values</b> 0 to 255</p> <p><b>Default Value</b> Default value is taken from the associated port parameter.</p> <p><b>Description</b> This parameter specifies the first of three additional characteristics that users can define to describe the TGs in a network.</p>
<p><b>Parameter</b> Second user-defined TG characteristic</p> <p><b>Valid Values</b> 0 to 255</p> <p><b>Default Value</b> Default value is taken from the associated port parameter.</p> <p><b>Description</b> This parameter specifies the second of three additional characteristics that users can define to describe the TGs in a network.</p>
<p><b>Parameter</b> Third user-defined TG characteristic</p> <p><b>Valid Values</b> 0 to 255</p> <p><b>Default Value</b> Default value is taken from the associated port parameter.</p> <p><b>Description</b> This parameter specifies the third of three additional characteristics that users can define to describe the TGs in a network.</p>

Table 24. Configuration Parameter List - Modify Dependent LU Server

Parameter Information
<p><b>Parameter</b> fully-qualified CP name of primary DLUS</p> <p><b>Valid Values</b> A string of up to 17 characters in the form of <i>netID.CPname</i>, where:</p> <ul style="list-style-type: none"> <li>• <i>netID</i> is a network ID from 1 to 8 characters</li> <li>• <i>CPname</i> is a control point name from 1 to 8 characters</li> </ul> <p>Each name must conform to the following rules:</p> <ul style="list-style-type: none"> <li>• First character: A to Z</li> <li>• Second to eighth characters: A to Z, 0 to 9</li> </ul> <p><b>Note:</b> An existing fully-qualified CP name, using the special characters @, \$, and # from the character set A, continues to be supported; however, these characters should not be used for new CP names.</p> <p><b>Default Value</b> The value specified in the default fully-qualified CP name of primary dependent LU server parameter.</p> <p><b>Description</b> This parameter specifies the fully-qualified CP name of the dependent LU server (DLUS) that is to be used for incoming requests from the downstream PU associated with this link station.</p>
<p><b>Parameter</b> fully-qualified CP name for backup DLUS</p> <p><b>Valid Values</b> A string of up to 17 characters in the form of <i>netID.CPname</i>, where:</p> <ul style="list-style-type: none"> <li>• <i>netID</i> is a network ID from 1 to 8 characters</li> <li>• <i>CPname</i> is a control point name from 1 to 8 characters</li> </ul> <p>Each name must conform to the following rules:</p> <ul style="list-style-type: none"> <li>• First character: A to Z</li> <li>• Second to eighth characters: A to Z, 0 to 9</li> </ul> <p><b>Note:</b> An existing fully-qualified CP name, using the special characters @, \$, and # from the character set A, continues to be supported; however, these characters should not be used for new CP names.</p> <p><b>Default Value</b> The value specified in the default fully-qualified CP name of backup dependent LU server parameter.</p> <p><b>Description</b> This parameter specifies the fully-qualified CP name of the dependent LU server (DLUS) that is to be used as a backup for the downstream PU associated with this link station. This parameter allows the default backup server to be overridden. A backup is not required, and the NULL value indicates the absence of a backup server. Note that NULL can be specified even when a default backup server has been defined (by erasing the default value that appears for this parameter).</p>

## APPN Configuration Commands

Table 25. Configuration Parameter List - Modify LLC Characteristics

Parameter Information
<p><b>Parameter</b> Remote APPN SAP</p> <p><b>Valid Values</b> Multiples of four in the hexadecimal range of X'04' to X'EC'.</p> <p><b>Default Value</b> Default value is taken from the associated port parameter.</p> <p><b>Description</b> This parameter specifies the Destination SAP (DSAP) address on the destination node to which data will be sent. This DSAP address value will appear in the LLC frame to identify the service access point (SAP) address associated with the adjacent node's APPN link station.</p>
<p><b>Parameter</b> Maximum number of outstanding I-format LPDUs (TW)</p> <p><b>Valid Values</b> 1 to 127</p> <p><b>Default Value</b> Default value is taken from the associated port parameter.</p> <p><b>Description</b> This parameter specifies the transmit Command Line option which is the maximum number of sequentially numbered I-format LPDUs that the link station may have unacknowledged at any given time.</p>
<p><b>Parameter</b> Receive window size</p> <p><b>Valid Values</b> 1 to 127</p> <p><b>Default Value</b> Default value is taken from the associated port parameter.</p> <p><b>Description</b> This parameter specifies the maximum number of unacknowledged sequentially numbered I-format LPDUs that the LLC link station can receive from the remote link station. RW is advertised in SNA XID frames and IEEE 802.2 XID frames. The XID receiver should set its effective TW to a value less than or equal to the value of the received RW to avoid overruns.</p>



## APPN Configuration Commands

Table 25. Configuration Parameter List - Modify LLC Characteristics (continued)

Parameter Information
<p><b>Parameter</b> Inactivity timer (Ti)</p> <p><b>Valid Values</b> 1 to 254 seconds</p> <p><b>Default Value</b> Default value is taken from the associated port parameter.</p> <p><b>Description</b> A link station uses Ti to detect an inoperative condition in either the remote link station or in the transmission media. If an LPDU is not received in the time interval specified by Ti, an S-format command LPDU with the poll bit set is transmitted to solicit remote link station status. Recovery is then based on the reply timer (T1).</p>
<p><b>Parameter</b> Reply timer (T1)</p> <p><b>Valid Values</b> 1 to 254 half-seconds</p> <p><b>Default Value</b> Default value is taken from the associated port parameter.</p> <p><b>Description</b> A link station uses T1 to detect a failure to receive a required acknowledgment or response from the remote link station. When T1 expires, the link station sends an S-format command link layer protocol data unit (LPDU) with the poll bit set to solicit remote link station status or any U-format command LPDUs that have not been responded to. The duration of T1 should take into account any delays introduced by underlying layers.</p>
<p><b>Parameter</b> Maximum number of retransmissions (N2)</p> <p><b>Valid Values</b> 1 to 254</p> <p><b>Default Value</b> Default value is taken from the associated port parameter.</p> <p><b>Description</b> This parameter specifies the maximum number of times an LPDU will be retransmitted following the expiration of the reply timer (T1).</p>

## APPN Configuration Commands

Table 25. Configuration Parameter List - Modify LLC Characteristics (continued)

Parameter Information
<p><b>Parameter</b> Receive acknowledgment timer (T2)</p> <p><b>Valid Values</b> 1 to 254 half-seconds</p> <p><b>Default Value</b> Default value is taken from the associated port parameter.</p> <p><b>Description</b> This parameter may be used in conjunction with the N3 counter to reduce acknowledgment traffic. A link station uses T2 to delay the sending of an acknowledgment for a received I-format LPDU. T2 is started when an I-format LPDU is received, and reset when an acknowledgment is sent in an I-format or S-format LPDU. If T2 expires, the link station must send an acknowledgment as soon as possible. The value of T2 must be less than that of T1, to ensure that the remote link station will receive the delayed acknowledgment before its T1 expires.</p>
<p><b>Parameter</b> Acknowledgment needed to increment working window</p> <p><b>Valid Values</b> 0 to 127 acknowledgments</p> <p><b>Default Value</b> Default value is taken from the associated port parameter.</p> <p><b>Description</b> When the working window (Ww) is not equal to the Maximum Transmit Window Size (Tw), this parameter is the number of transmitted I-format LPDUs that must be acknowledged before the working window can be incremented (by 1). When congestion is detected, by the lost of I-format LPDUs, Ww is set to 1.</p>

Table 26. Configuration Parameter List - Modify HPR Defaults

Parameter Information
<p><b>Parameter</b> Inactivity timer override for HPR (HPR Ti)</p> <p><b>Valid Values</b> 1 to 254 seconds</p> <p><b>Default Value</b> Default value is taken from the associated port parameter.</p> <p><b>Description</b> This parameter specifies the HPR override LLC inactivity timer (HPR Ti) that is to be used when HPR is supported by this link station. This parameter overrides the value taken from the default inactivity timer override for the HPR parameter.</p> <p>This parameter supersedes the value of the LLC inactivity timer (Ti) parameter specified on the Modify Logical Link Control (LLC) Characteristics parameter when HPR is supported.</p>

## APPN Configuration Commands

Table 26. Configuration Parameter List - Modify HPR Defaults (continued)

Parameter Information
<p><b>Parameter</b> Reply timer override for HPR (HPR T1)</p> <p><b>Valid Values</b> 1 to 254 half-seconds</p> <p><b>Default Value</b> Default value is taken from the associated port parameter.</p> <p><b>Description</b> This parameter specifies the HPR override LLC reply timer (HPR T1) that is to be used when HPR is supported by this link station. This parameter overrides the value taken from the default reply timer override for HPR parameter specified on HPR Defaults.</p> <p>This parameter supersedes the value of the LLC reply timer (T1) parameter specified on the Modify Logical Link Control (LLC) Characteristics parameter when HPR is supported.</p>
<p><b>Parameter</b> Maximum number retransmission (HPR N2)</p> <p><b>Valid Values</b> 1 to 2 160 000</p> <p><b>Default Value</b> Default value is taken from the associated port parameter.</p> <p><b>Description</b> This parameter specifies the HPR override LLC maximum number of retransmissions (HPR N2) that is to be used when HPR is supported by this link station. This parameter overrides the value taken from the default maximum number of retransmissions for HPR parameter specified on the HPR LLC Override defaults.</p> <p>This parameter supersedes the value of the LLC maximum number of retransmissions (N2) parameter specified on the Modify Logical Link Control (LLC) Characteristics parameter when HPR is supported.</p>
<p><b>Parameter</b> Limited Resource Timer</p> <p><b>Valid Values</b> 1 to 216000 seconds</p> <p><b>Default Value</b> Default value is taken from the associated port parameter.</p> <p><b>Description</b> This parameter specifies the timer value associated with the limited resource.</p>

### Syntax:

**add** lu-name

You will be prompted to enter a station name to associate this LU with.

You will be prompted to enter a value for the following parameter. The parameter range will be shown in parentheses ( ). The parameter default will be shown in square brackets [ ].

## APPN Configuration Commands

Table 27. Configuration Parameter List - LEN End Node LU Name

Parameter Information
<p><b>Parameter</b> fully-qualified LU name</p>
<p><b>Valid Values</b> fully-qualified (explicit) LU name Generic (partially explicit) LU name Wildcard entry</p> <p>A string of up to 17 characters in the form of <i>netID.LUname</i>, where:</p> <ul style="list-style-type: none"><li>• <i>netID</i> is a network ID from 1 to 8 characters</li><li>• <i>LUname</i> is a control point name from 1 to 8 characters</li></ul> <p>Each name must conform to the following rules:</p> <ul style="list-style-type: none"><li>• First character: A to Z</li><li>• Second to eighth characters: A to Z, 0 to 9</li></ul> <p><b>Note:</b> An existing fully-qualified LU name, using the special characters @, \$, and # from the character set A, continues to be supported; however, these characters should not be used for new LU names.</p> <p>To reduce the number of fully-qualified LU names you need to specify, you can define a generic LU name using the wildcard character (*) to represent a portion of the LU name (<i>LUname</i>). You can also define a wildcard entry by using the wildcard character as the whole LU name.</p>
<p><b>Default Value</b> None</p>
<p><b>Description</b> This parameter specifies the fully-qualified names of LUs associated with a LEN end node. The specified LU names are registered in the network node's directory services database. If a name is not registered, the network node cannot locate the LU (unless the LU name is the same as the CP name of the LEN end node).</p> <p>You need to specify a fully-qualified LU name, which consists of a network ID and the LU name. The network ID is the name of the network that contains the adjacent LEN end node. The LU name is the name of a logical unit accessible through the adjacent LEN end node.</p>

### Syntax:

**add** connection-network

You will be prompted to enter values for the following parameters. The parameter range will be shown in parentheses ( ). The parameter default will be shown in square brackets [ ].

Table 28. Configuration Parameter List - Connection Network - Detail

Parameter Information
<p><b>Parameter</b> Fully-qualified Connection network name (required for each connection network defined)</p> <p><b>Valid Values</b> A string of 1 to 8 characters:</p> <ul style="list-style-type: none"> <li>• First character: A to Z</li> <li>• Second to eighth characters: A to Z, 0 to 9</li> </ul> <p><b>Note:</b> An existing connection network of which this node desires to become a member, named using the special characters @, \$, and # from the character set A, continues to be supported; however, these characters should not be used for new connection network names.</p> <p><b>Default Value</b> None</p> <p><b>Description</b> This parameter specifies the fully-qualified name of the connection network being defined on this router network node. Since this name becomes the CP name of the virtual routing node (VRN), the name must be unique among all CP and LU names in the APPN network (same as in the local Control Point Name).</p> <p>All nodes that are members of a given connection network must use the same VRN Name.</p> <p>The fully-qualified VRN Name (CP name of VRN) has the form: <i>NetworkID.ConnectionNetworkName</i> where <i>NetworkID</i> is this router network node's network identifier.</p>
<p><b>Parameter</b> Port type (required)</p> <p><b>Valid Values</b> Token-ring, Ethernet, Frame Relay BAN, IP</p> <p><b>Note:</b> If the <b>port type</b> is IP, no <b>port name</b> will be specified since there is only one IP port.</p> <p><b>Default Value</b> None</p> <p><b>Description</b> This parameter specifies the type of ports providing connectivity to the SATF for the connection network being defined. A given connection network only supports one type of port with one set of characteristics.</p>

## APPN Configuration Commands

Table 28. Configuration Parameter List - Connection Network - Detail (continued)

Parameter Information
<p><b>Parameter</b> Port name (required)</p> <p><b>Valid Values</b> Name of port on which APPN routing has been enabled. <b>Note:</b> If the <b>port type</b> is IP, no <b>port name</b> will be specified since there is only one IP port.</p> <p><b>Default Value</b> None</p> <p><b>Description</b> This parameter specifies the name of a port providing connectivity to the shared access transport facility (SATF) for the connection network being defined.</p> <p>All ports defined for a given connection network must be the same type and have the same characteristics. <b>Note:</b> For a <b>port type</b> of IP, additional ports added to an IP connection network can be any port that IP has been defined to use.</p> <p>At least one additional port besides the IP port must be added for the connection network to be used.</p> <p>Since the IP port is a pseudo port that always comes up when the node is initialized, real ports that IP is defined on (TR, FR, ...) must be added to the CN. When at least one of these real ports is up, the connection network link is assumed active. When all of these real ports is down, the connection network link is assumed to be inactive.</p>
<p><b>Parameter</b> Limited Resource Timer</p> <p><b>Valid Values</b> 1 to 216000 seconds</p> <p><b>Default Value</b> 180</p> <p><b>Description</b> This parameter specifies the timer value associated with a limited resource.</p>
<p><b>Parameter</b> DLCI number</p> <p><b>Valid Values</b> 16 to 1007</p> <p><b>Default Value</b> None</p> <p><b>Description</b> This parameter specifies the DLCI number used by the router to connect to the frame relay network. When the router initiates a connection to a link station on the LAN through the connection network, it will use this DLCI number to connect to the frame relay network.</p>

## APPN Configuration Commands

Table 28. Configuration Parameter List - Connection Network - Detail (continued)

Parameter Information
<b>Parameter</b> BAN destination address (BDA)
<b>Valid Values</b> X'0000 0000 0000' to X'7FFF FFFF FFFF'
<b>Default Value</b> X'0000 0000 0000'
<b>Description</b> This parameter specifies the BAN destination address configured in the node that is performing the BAN function. If you are using bridging to connect the LAN network to the frame relay network, specify X'0000 0000 0000' as the value of this parameter. In this case, the MAC address reported to the APPN topology for the connection network TG is the BNI MAC address coded on the APPN port associated with this connection network definition.

Table 29. Configuration Parameter List - TG Characteristics (Connection Network)

Parameter Information
<b>Parameter</b> Cost per connect time
<b>Valid Values</b> 0 to 255
<b>Default Value</b> 0
<b>Description</b> This parameter expresses the relative cost of maintaining a connection over the associated TG. The units are user-defined and are typically based on the applicable tariffs of the transmission facility being used. The assigned values should reflect the actual expense of maintaining a connection over the TG relative to all other TGs in the network. A value of zero means that connections over the TG may be made at no additional cost (as in the case of many non-switched facilities). Higher values represent higher costs.
<b>Parameter</b> Cost per byte
<b>Valid Values</b> 0 to 255
<b>Default Value</b> 0
<b>Description</b> This parameter expresses the relative cost of transmitting a byte over the associated TG. The units are user-defined and the assigned value should reflect the actual expenses incurred for transmitting over the TG relative to all other TGs in the network. A value of zero means that bytes may be transmitted over the TG at no additional cost. Higher values represent higher costs.

## APPN Configuration Commands

Table 29. Configuration Parameter List - TG Characteristics (Connection Network) (continued)

Parameter Information
<p><b>Parameter</b> Security</p> <p><b>Valid Values</b></p> <p>Nonsecure – all else (for example, satellite-connected, or located in a nonsecure country).</p> <p>Public switched network – secure in the sense that route is not predetermined.</p> <p>Underground cable – located in secure country (as determined by the network administrator).</p> <p>Secure conduit – not guarded, (for example, pressurized pipe).</p> <p>Guarded conduit – protected against physical tapping.</p> <p>Encrypted – link-level encryption is provided.</p> <p>Guarded radiation – guarded conduit containing the transmission medium; protected against physical and radiation tapping.</p> <p><b>Default Value</b> Nonsecure</p> <p><b>Description</b> This parameter indicates the level of security protection associated with the TG. If security attributes other than the architecturally-defined ones are needed, one of the user-defined TG characteristics may be used to specify additional values.</p>
<p><b>Parameter</b> Propagation delay</p> <p><b>Valid Values</b></p> <ul style="list-style-type: none"> <li>• Minimum LAN – less than 480 microseconds</li> <li>• Telephone – between .48 and 49.152 milliseconds</li> <li>• Packet switched – between 49.152 and 245.76 milliseconds</li> <li>• Satellite – greater than 245.76 milliseconds Maximum</li> </ul> <p><b>Default Value</b> LAN</p> <p><b>Description</b> This parameter specifies the approximate range for the length of time that it takes for a signal to propagate from one end of the TG to the other.</p>



## APPN Configuration Commands

Table 29. Configuration Parameter List - TG Characteristics (Connection Network) (continued)

Parameter Information
<p><b>Parameter</b> Effective capacity</p> <p><b>Valid Values</b> 2 hexadecimal digits in the range X'00' to X'FF'</p> <p><b>Default Value</b> X'75'</p> <p><b>Description</b> This parameter specifies the effective maximum bit transmission rate for this connection network TG. Effective capacity specifies the maximum effective rate for both physical links and logical links.</p> <p>The effective capacity is encoded as a single-byte representation. The values X'00' and X'FF' are special cases used to denote minimum and maximum capacities. The range of the encoding is very large; however, only 256 values in the range may be specified.</p>
<p><b>Parameter</b> First user-defined characteristic</p> <p><b>Valid Values</b> 0 to 255</p> <p><b>Default Value</b> 128</p> <p><b>Description</b> This parameter specifies the first of three additional characteristics that users may define to describe the TGs in the network. The default value of 128 allows a subset of TGs to be defined as more or less desirable than the rest without defining values for all TGs.</p>
<p><b>Parameter</b> Second user-defined characteristic</p> <p><b>Valid Values</b> 0 to 255</p> <p><b>Default Value</b> 128</p> <p><b>Description</b> This parameter specifies the second of three additional characteristics that users may define to describe the TGs in the network. The default value of 128 allows a subset of TGs to be defined as more or less desirable than the rest without defining values for all TGs.</p>

## APPN Configuration Commands

Table 29. Configuration Parameter List - TG Characteristics (Connection Network) (continued)

Parameter Information
<b>Parameter</b> Third user-defined characteristic
<b>Valid Values</b> 0 to 255
<b>Default Value</b> 128
<b>Description</b> This parameter specifies the third of three additional characteristics that users may define to describe the TGs in the network. The default value of 128 allows a subset of TGs to be defined as more or less desirable than the rest without defining values for all TGs.

### Syntax:

**add** mode

You will be prompted to enter values for the following parameters. The parameter range will be shown in parentheses ( ). The parameter default will be shown in square brackets [ ].

Table 30. Configuration Parameter List - APPN COS - Mode Name to COS Name Mapping - Detail

Parameter Information
<b>Parameter</b> Mode name (required)
<b>Valid Values</b> A string of 1 to 8 characters: <ul style="list-style-type: none"><li>• First character: A to Z</li><li>• Second to eighth characters: A to Z, 0 to 9</li></ul> <p><b>Note:</b> An existing mode name for an existing network, of which this router network node is to become a member, using the special characters @, \$, and # from the character set A, continues to be supported; however, these characters should not be used for new mode names.</p>
<b>Default Value</b> None
<b>Description</b> This parameter specifies the Mode name for the Mode name to COS name mapping being defined. See "COS Options" on page 38 for additional information about Mode name to COS mapping.

## APPN Configuration Commands

Table 30. Configuration Parameter List - APPN COS - Mode Name to COS Name Mapping - Detail (continued)

Parameter Information
<p><b>Parameter</b> COS name (required)</p> <p><b>Valid Values</b> The name of a previously defined COS definition, selected from the list of COS names defined for this router network node.</p> <p><b>Default Value</b> None</p> <p><b>Description</b> This parameter specifies the COS Name to be associated with the Mode name being defined for this mode name to COS name mapping.</p>
<p><b>Parameter</b> Session-level pacing Command Line option size</p> <p><b>Valid Values</b> 1 to 63</p> <p><b>Default Value</b> 7</p> <p><b>Description</b> This parameter specifies the session-level pacing Command Line option size. This parameter has different definitions depending upon the type of pacing used:</p> <ul style="list-style-type: none"><li>• For fixed session-level pacing:<ul style="list-style-type: none"><li>– The session-level pacing Command Line option size parameter specifies the receive pacing Command Line option for this node.</li><li>– The value of this parameter is the suggested receive pacing Command Line option for the adjacent node.</li></ul></li><li>• For adaptive session-level pacing:<ul style="list-style-type: none"><li>– The session-level pacing Command Line option size parameter specifies a tuning parameter to be used as the minimum size for Isolated Pacing Messages sent by the adjacent nodes.</li></ul></li></ul>

### Syntax:

**add** additional-port-to-connection-network

You will be prompted to enter values for the following parameters. The parameter range will be shown in parentheses ( ). The parameter default will be shown in square brackets [ ].

**Note:** You can have a maximum of 5 ports per connection network definition.

## APPN Configuration Commands

Table 31. Configuration Parameter List - APPN Additional port to Connection Network

Parameter Information
<p><b>Parameter</b> Connection network name (fully-qualified) (required for each connection network defined)</p> <p><b>Valid Values</b> A string of 1 to 8 characters:</p> <ul style="list-style-type: none"><li>• First character: A to Z</li><li>• Second to eighth characters: A to Z, 0 to 9</li></ul> <p><b>Note:</b> An existing connection network of which this node desires to become a member, named using the special characters @, \$, and # from the character set A, continues to be supported; however, these characters should not be used for new connection network names.</p> <p><b>Default Value</b> None</p> <p><b>Description</b> This parameter specifies the name of the connection network being defined on this router network node. Since this name becomes the CP name of the virtual routing node (VRN), the name must be unique among all CP and LU names in the APPN network (same as in the local Control Point Name).</p> <p>All nodes that are members of a given connection network must use the same VRN Name.</p> <p>The fully-qualified VRN Name (CP name of VRN) has the form: <i>NetworkID.ConnectionNetworkName</i> where <i>NetworkID</i> is this router network node's network identifier.</p>
<p><b>Parameter</b> Port name</p> <p><b>Valid Values</b> A unique unqualified name that is automatically generated by the Command Line.</p> <p>The name will consist of:</p> <ul style="list-style-type: none"><li>• TR (token-ring)</li><li>• EN (Ethernet)</li></ul> <p><b>Default Value</b> Unqualified name generated by the Command Line.</p> <p><b>Description</b> This parameter specifies the name representing this port.</p> <p>When the connection network that the port is being added to is IP, only ports that IP is defined to have an interface on will be permitted to be added to the IP CN. At least one real port that has IP defined must be added to the IP CN for the CN to become active and to be used.</p>

### Syntax:

**add** focal\_point

You will be prompted to enter values for the following parameters. The parameter range will be shown in parentheses ( ). The parameter default

## APPN Configuration Commands

will be shown in square brackets [ ].

Table 32. Configuration Parameter List - APPN Implicit Focal Point

Parameter Information
<b>Parameter</b> focal point
<b>Valid Values</b> A fully-qualified CP name
<b>Default Value</b> Blanks
<b>Description</b> This parameter specifies the fully-qualified CP name representing this focal point.  The first focal point added is the primary implicit focal point. Up to 8 additional backup implicit focal points may be added by invoking <b>Add focal_point</b> multiple times. If the primary implicit focal point is taken off the focal point list with <b>Delete focal_point</b> , the first backup implicit focal point, if there is one, becomes the primary implicit focal point.

### Syntax:

**add** local-pu

You will be prompted to enter values for the following parameters. The parameter range will be shown in parentheses ( ). The parameter default will be shown in square brackets [ ].

Table 33. Configuration Parameter List - APPN Local PU

Parameter Information
<b>Parameter</b> Station name
<b>Valid Values</b> A string of 1 to 8 characters: <ul style="list-style-type: none"><li>• First character: A to Z</li><li>• Second to eighth characters: A to Z, 0 to 9</li></ul>
<b>Default Value</b> None
<b>Description</b> This parameter specifies the name representing the link between the DLUR and the PU.

## APPN Configuration Commands

Table 33. Configuration Parameter List - APPN Local PU (continued)

Parameter Information
<p><b>Parameter</b> Primary DLUS name</p> <p><b>Valid Values</b> A string of 1 to 8 characters:</p> <ul style="list-style-type: none"><li>• First character: A to Z</li><li>• Second to eighth characters: A to Z, 0 to 9</li></ul> <p><b>Default Value</b> None</p> <p><b>Description</b> This parameter specifies the name to be used to override the primary DLUS configured for this node.</p>
<p><b>Parameter</b> Secondary DLUS name</p> <p><b>Valid Values</b> A string of 1 to 8 characters:</p> <ul style="list-style-type: none"><li>• First character: A to Z</li><li>• Second to eighth characters: A to Z, 0 to 9</li></ul> <p><b>Default Value</b> None</p> <p><b>Description</b> This parameter specifies the name to be used to override the secondary DLUS configured for this node.</p>
<p><b>Parameter</b> Autoactivate</p> <p><b>Valid Values</b> Yes or No</p> <p><b>Default Value</b> Yes</p> <p><b>Description</b> This parameter specifies whether to activate this link at start-up.</p>

### Syntax:

**add** routing\_list

**Note:** These questions are asked only if you have configured the node as a border node.

There are a number of editing shortcut keys available to speed the modification of existing data in a previously configured routing list. These shortcut keys may be used when you are prompted for the **Destination LUs** and the **Routing CPs**.

- **Enter** alone will retain the currently displayed name.
- **Space bar** followed by **Enter** will delete the currently displayed name.

## APPN Configuration Commands

- Character data followed by **Enter** will replace the currently displayed name with the new character data.
- **9** followed by **Enter** will jump to the end of the list where new names can be appended.
- At the end of a list, **Enter** alone completes the list.

Table 34. Configuration Parameter List - Routing List Configuration

Parameter Information
<p><b>Parameter</b> Routing list name</p> <p><b>Valid Values</b> Character string up to 20 characters in length with no imbedded blanks. Mixed case and special characters are allowed.</p> <p><b>Default Value</b> Blank</p> <p><b>Description</b> This parameter identifies a specific routing list for modification, listing, or deletion by the configuration code. It is not used by the operational code. Up to 255 routing lists may be configured depending upon availability of configuration memory. Case is respected.</p>
<p><b>Parameter</b> Subnet visit count</p> <p><b>Valid Values</b> 1 to 255</p> <p><b>Default Value</b> Default taken from corresponding node level parameter</p> <p><b>Description</b> This parameter specifies how many networks a locate search procedure may traverse.</p>
<p><b>Parameter</b> Dynamic routing list updates</p> <p><b>Valid Values</b> 0 (none)  1 (full)  2 (limited)</p> <p><b>Default Value</b> Default value taken from corresponding node level parameter</p> <p><b>Description</b> This parameter controls whether entries can be automatically added to the node's temporary subnet routing list. It can be set to the same values as the analogous node level parameter. If this function is enabled the automatically added entries are only added to the temporary copy of the routing list.</p>

## APPN Configuration Commands

Table 34. Configuration Parameter List - Routing List Configuration (continued)

Parameter Information
<p><b>Parameter</b> Enable routing list optimization</p> <p><b>Valid Values</b> Yes or No</p> <p><b>Default Value</b> Yes</p> <p><b>Description</b> Indicates whether the node is allowed to reorder the subnetwork routing list so that entries most likely to succeed come first. This reordering occurs in the internal temporary copy of the routing list.</p>
<p><b>Parameter</b> Destination LU found via this list</p> <p><b>Valid Values</b></p> <p>A fully-qualified LU name with optional trailing wildcard. Legal characters for the LU name are: A-Z, @, \$, #, 0-9.</p> <p>The first character of the NETID part and of the LU name part must be non-numeric.</p> <p>Any of the FQ LU names may be terminated with a wild card "*" character to designate the range of LUs. For example,</p> <ul style="list-style-type: none"> <li>• *</li> <li>• NETI*</li> <li>• NETI.LUA*</li> </ul> <p><b>Default Value</b> Blank</p> <p><b>Description</b> This parameter specifies a list of destination LUs that can be found via this routing list.</p> <p>This question will be repeated until terminated with a null entry.</p> <p><b>Notes:</b></p> <ol style="list-style-type: none"> <li>1. Only a single entry among all of the routing lists may have a standalone "*". This will match all LUs, and the routing list containing it is known as the default routing list.</li> <li>2. All the editing shortcuts described at the beginning of this table are available to speed modification of a previously configured routing CP(s) list.</li> <li>3. Any given LU name may not be duplicated in another routing list.</li> <li>4. Maximum number of LU names that may be specified: <ul style="list-style-type: none"> <li>• 2212 - 126</li> </ul> </li> </ol>



Table 34. Configuration Parameter List - Routing List Configuration (continued)

Parameter Information
<p><b>Parameter</b> Routing CP and optional subnet visit count</p> <p><b>Valid Values</b> A fully-qualified CP name consisting of 1 to 17 characters followed by an optional numeric subnet visit count. Legal characters for the CP name are: A-Z, @, \$, #, 0-9</p> <p>The first character of the NETID part and of the CP name part must be non-numeric. The optional subnet visit count range is 1 to 255 and should be separated from the fully-qualified CP name by one or more spaces.</p> <p><b>Default Value</b> Blank for fully-qualified CP name and node-level setting for subnet visit count.</p> <p><b>Description</b> This parameter specifies a list of one or more fully-qualified CP names of CPs that might know how to reach one or more of the previously configured destination LUs.</p> <p>Each of the following special keywords may be used once in any given routing list:</p> <ul style="list-style-type: none"> <li>• "*" - equivalent to specifying all native BNs, all adjacent non-native BNs, and all adjacent non-native NNs.</li> <li>• "**SELF" - equivalent to specifying the local node's fully-qualified CP name</li> <li>• "**EBNS" - equivalent to specifying all native BNs</li> </ul> <p>This question will be repeated until terminated with a null entry.</p> <p><b>Notes:</b></p> <ol style="list-style-type: none"> <li>1. All the editing shortcuts described at the beginning of this table are available to speed modification of a previously configured routing CP list.</li> <li>2. If you configure "**SELF" as a CP name, you cannot configure the local node's CP name.</li> <li>3. Any given routing list can have the following maximum number of CP names and keywords: <ul style="list-style-type: none"> <li>• 2212 - 144</li> </ul> </li> <li>4. Across all routing lists, you may use no more than the following number of different CP names and keywords: <ul style="list-style-type: none"> <li>• 2212 - 144</li> </ul> </li> <li>5. Any given CP name or keyword may appear in no more than 255 routing lists.</li> </ol>

**Syntax:**

**add** cos\_mapping\_table

**Note:** These questions are asked only if you have configured the node as a border node.

The editing shortcut keys specified at the beginning of the routing list table are also valid here. Use them to speed modification of the non-native CP names and COS name pairs.

## APPN Configuration Commands

Table 35. Configuration Parameter List - COS Mapping Table Configuration

Parameter Information
<p><b>Parameter</b> COS mapping table name</p> <p><b>Valid Values</b> Character string up to 20 characters in length, with no imbedded blanks. Mixed case and special characters are allowed.</p> <p><b>Default Value</b> Blank</p> <p><b>Description</b> This parameter identifies a specific COS mapping table. It allows you to identify the table for modification, listing, or deletion by the configuration software. It is not used by the operational software. Up to 255 COS mapping tables may be configured depending upon availability of configuration memory. Case is respected.</p>
<p><b>Parameter</b> Non-native NETID or CP name</p> <p><b>Valid Values</b> A fully-qualified CP name with optional trailing wildcard. Legal characters for the CP name are: A-Z, @, \$, #, 0-9</p> <p>The first character of the NETID part and of the CP name part must be non-numeric. Any of the fully-qualified CP names may be terminated with a wildcard "*" character to designate a range of CPs. For example:</p> <ul style="list-style-type: none"><li>• *</li><li>• NET1*</li><li>• NET1.LUA*</li></ul> <p><b>Default Value</b> Blank</p> <p><b>Description</b> This parameter specifies a list of one or more non-native networks that this mapping table applies to. This question is repeated until terminated with a null entry.</p> <p><b>Notes:</b></p> <ol style="list-style-type: none"><li>1. Only a single entry among all the routing lists may have a standalone "*" . This will match all non-native networks, and is known as the default routing list.</li><li>2. Any given CP name may not be duplicated in another COS mapping table.</li><li>3. Maximum number of CP names that may be specified:<ul style="list-style-type: none"><li>• 2212 - 126</li></ul></li></ol>

Table 35. Configuration Parameter List - COS Mapping Table Configuration (continued)

Parameter Information
<p><b>Parameter</b> Native and non-native COS-name pair</p>
<p><b>Valid Values</b> A pair of COS names, separated by a blank. Legal characters are: A-Z, @, \$, #, 0-9</p> <p>The first character of each name must be non-numeric.</p>
<p><b>Default Value</b> Blank</p>
<p><b>Description</b> This parameter identifies a pair of COS names. A native COS name is followed by the corresponding non-native COS name.</p> <p>For any given COS mapping table, one of the COS name pairs may specify the non-native COS name as "*" . This designates the default entry to use for all non-native COS names that do not explicitly match another entry in the table.</p> <p>One COS name pair cannot exactly match another COS name pair in a given table. However, a given native COS name can be used in multiple entries, and it is also okay for a given non-native COS name to be used in multiple entries. The operational software will use the first entry it finds.</p> <p>This question will be repeated until terminated with a null entry.</p> <p><b>Notes:</b></p> <ol style="list-style-type: none"> <li>1. The native and non-native names cannot be identical. Only COS names that need to be changed should be specified.</li> <li>2. A given native or non-native COS name may appear in multiple entries, but you cannot have two identical COS name pairs.</li> <li>3. When you have multiple native COS names mapping to the same non-native COS name, the border node will use the first of those mappings when it needs to map from non-native to native. Similarly, when you have multiple non-native COS names mapping to a common native COS name, the border node will use the first of those mappings when it needs to map from native to non-native.</li> <li>4. Any given COS mapping table can have the following maximum number of COS name pairs: <ul style="list-style-type: none"> <li>• 2212 - 46</li> </ul> </li> <li>5. Across all COS mapping tables, you may use no more than the following number of native COS names: <ul style="list-style-type: none"> <li>• 2212 - 144</li> </ul> <p style="margin-left: 40px;">There is no analogous limit for non-native COS names.</p> </li> <li>6. Any given native COS name may appear no more than 255 times across all routing lists.</li> </ol>

## Delete

Use the **delete** command to delete:

**Syntax:**

**delete**            port *port-name*

## APPN Configuration Commands

link *link-station-name*  
lu-name *lu-name*  
connection-network *connection-network-name*  
additional-port-to-connection-network *cn-port-name*  
mode *name*  
focal\_point *focal-point-name*  
local-pu  
routing\_list *routing list name*  
cos\_mapping\_table *mapping table name*

## List

Use the **list** command to list:

### Syntax:

list            all  
                  node  
                  traces  
                  management  
                  hpr  
                  dlur  
                  port *port name*  
                  link station *link station name*  
                  lu name *lu name*  
                  mode name *mode name*  
                  connection network *connection network name*  
                  focal\_point  
                  routing\_list *routing list name*  
                  cos\_mapping\_table *mapping table name*

## Activate\_new\_config

Use the **activate\_new\_config** command to read the configuration into non-volatile memory.

### Syntax:

activate\_new\_config

TN3270E

Table 36. TN3270E Configuration Command Summary

Command	Function	See page:
? (Help)	Displays all the commands available for this command level or lists the options for specific commands (if available). See "Getting Help" on page xxvi.	
Set	tn3270e	178
Add	Adds or updates the following:	
	implicit-pool	179
	lu	182
	mapping	186
	port	187
Delete	Deletes the following:	187
	<ul style="list-style-type: none"> <li>• implicit-pool</li> <li>• lu</li> <li>• mapping</li> <li>• port</li> </ul>	
List all	Lists the configuration memory	190
Exit	Returns you to the previous command level. See "Exiting a Lower Level Environment" on page xxvi.	

**Syntax:**

**set**

You will be prompted to enter values for the following parameters. The parameter range will be shown in parentheses ( ). The parameter default will be shown in square brackets [ ].

Table 37. Configuration Parameter List - Set TN3270E

Parameter Information
<p><b>Parameter</b> Enable TN3270E Server</p> <p><b>Valid Values</b> Yes or No</p> <p><b>Default Value</b> Yes</p> <p><b>Description</b> This parameter specifies whether TN3270E Server support will be enabled.</p>

## APPN Configuration Commands

Table 37. Configuration Parameter List - Set TN3270E (continued)

Parameter Information
<p><b>Parameter</b> TN3270E Server IP Address</p> <p><b>Valid values</b> Any IP address</p> <p><b>Default Value</b> None</p> <p><b>Description</b> This parameter is the IP address associated with the TN3270E Server.</p>
<p><b>Parameter</b> Port number</p> <p><b>Valid Values</b> 1 to 65535</p> <p><b>Default Value</b> 23</p> <p><b>Description</b> This parameter specifies the port number associated with the TN3270E Server.</p>
<p><b>Parameter</b> Enable Client IP address to LU name mapping?</p> <p><b>Valid values</b> Yes or No</p> <p><b>Default Value</b> No</p> <p><b>Description</b> This parameter specifies whether client IP address to LU name mapping occurs.</p>
<p><b>Parameter</b> Default pool name</p> <p><b>Valid Values</b> Any alphanumeric string of 1 to 8 characters</p> <p><b>Default Value</b> PUBLIC</p> <p><b>Description</b> This parameter specifies the name of the default pool. This pool is used when TN3270 clients connect and do not specify an LU/pool name.</p>

## APPN Configuration Commands

Table 37. Configuration Parameter List - Set TN3270E (continued)

Parameter Information
<p><b>Parameter</b> NetDisp Advisor Port Number</p> <p><b>Valid Values</b> 1 to 65535</p> <p><b>Default Value</b> 10008</p> <p><b>Description</b> This parameter sets the port number for the Network Dispatcher Advisor.</p>
<p><b>Parameter</b> Keepalive type</p> <p><b>Valid Values</b></p> <ul style="list-style-type: none"><li>0 None</li><li>1 Timing mark</li><li>2 NOP</li></ul> <p><b>Default Value</b> 0</p> <p><b>Description</b> This parameter specifies the Keepalive type.</p> <p>A Keepalive type of <i>Timing mark</i> requires responses from the client within the amount of time specified using the <b>Timer</b> parameter .</p> <p>A Keepalive type of <i>NOP</i> specifies that the client will not send back a response to the Keepalive message. Notification that the client is no longer there will come from TCP.</p>
<p><b>Parameter</b> Frequency</p> <p><b>Valid Values</b> 1 to 65535 seconds</p> <p><b>Default Value</b> 60</p> <p><b>Description</b> This parameter specifies how often the Keepalive message is sent to the client.</p>
<p><b>Parameter</b> Timer</p> <p><b>Valid Values</b> 1 to 65536 seconds</p> <p><b>Default Value</b> 10</p> <p><b>Description</b> This parameter sets the timer value to be used with the Keepalive function.</p>

## APPN Configuration Commands

Table 37. Configuration Parameter List - Set TN3270E (continued)

Parameter Information
<p><b>Parameter</b> Automatic logoff</p> <p><b>Valid Values</b> Yes or No</p> <p><b>Default Value</b> No</p> <p><b>Description</b> This parameter specifies whether automatic logoff will be enabled.</p>
<p><b>Parameter</b> Time</p> <p><b>Valid Values</b> 1 to 65535 minutes</p> <p><b>Default Value</b> 30</p> <p><b>Description</b> This parameter sets the time that the TN3270E link can be idle before being automatically logged off.</p>
<p><b>Parameter</b> IPv4 Precedence</p> <p><b>Valid Values</b> Yes or No</p> <p><b>Default Value</b> No</p> <p><b>Description</b> This parameter sets the IPv4 precedence value, which allows priority queueing of IPv4 encapsulated packets.</p>

### Syntax:

**add** implicit-pool

This command defines a pool of LUs as opposed to the **add lu** command which adds a single LU. You will be prompted to enter values for the following parameters. The parameter range will be shown in parentheses ( ). The parameter default will be shown in square brackets [ ].



Table 38. Configuration Parameter List - Add TN3270E Implicit

Parameter Information
<p><b>Parameter</b> Pool name</p> <p><b>Valid Values</b> A string of 1 to 8 characters:</p> <ul style="list-style-type: none"> <li>• First character: A to Z</li> <li>• Second to eighth characters: A to Z, 0 to 9</li> </ul> <p><b>Default Value</b> PUBLIC</p> <p><b>Description</b> This parameter specifies the name of the LU pool to be used when TN3270 clients connect.</p>
<p><b>Parameter</b> Pool class</p> <p><b>Valid Values</b> 1 or 2, where:</p> <ol style="list-style-type: none"> <li>1. Implicit workstation</li> <li>2. Implicit printer</li> </ol> <p><b>Default Value</b> 1</p> <p><b>Description</b> This parameter specifies type of LU pool.</p>
<p><b>Parameter</b> Station name</p> <p><b>Valid Values</b> A string of 1 to 8 characters:</p> <ul style="list-style-type: none"> <li>• First character: A to Z</li> <li>• Second to eighth characters: A to Z, 0 to 9</li> </ul> <p><b>Default Value</b> None</p> <p><b>Description</b> This parameter specifies the name representing the link between the DLUR and the PU or the subarea link over which SNA data will flow.</p>

## APPN Configuration Commands

Table 38. Configuration Parameter List - Add TN3270E Implicit (continued)

Parameter Information
<p><b>Parameter</b> LU Name Mask</p> <p><b>Valid Values</b> A string of 1 to 5 characters:</p> <ul style="list-style-type: none"> <li>• First character: A to Z, @, \$, and #</li> <li>• Second to eighth characters: A to Z, 0 to 9</li> </ul> <p><b>Default Value</b> @01LU</p> <p><b>Description</b> This parameter specifies the mask to be used to ensure that the LU names will not duplicate other names in the network.</p> <p>LU names are generated by appending the NAU address to the end of the LU name mask. When not specifying an address range, NAU addresses from 2 - 253 will be checked to see if the address is unused. If the address is available, it will be used. Otherwise, the next NAU address will be tried.</p> <p>For example, if the LU name mask is FRED, the possible LU names are [FRED2, FRED3, ..., FRED253].</p>
<p><b>Parameter</b> LU type</p> <p><b>Valid Values</b></p> <ul style="list-style-type: none"> <li>• 1 - 3270 Mod 2 display</li> <li>• 2 - 3270 Mod 3 display</li> <li>• 3 - 3270 Mod 4 display</li> <li>• 4 - 3270 Mod 5 display</li> <li>• 5 - 3270 printer</li> <li>• 6 - SCS printer</li> </ul> <p><b>Default Value</b> 1</p> <p><b>Description</b> This parameter specifies the type of dependent LU for the LU being added.</p>
<p><b>Parameter</b> Specify LU address range?</p> <p><b>Valid Values</b> Yes or No</p> <p><b>Default Value</b> No</p> <p><b>Description</b> This parameter specifies whether you want to define an LU address range.</p>

Table 38. Configuration Parameter List - Add TN3270E Implicit (continued)

Parameter Information	
<b>Parameter</b>	LU address range
<b>Valid Values</b>	Any range of values within 2 - 253
<b>Default Value</b>	none
<b>Description</b>	<p>This parameter specifies LU address range.</p> <p>The LU address range can be specified by using the following format:</p> <p style="padding-left: 40px;">lower_address_bound-upper_address_bound</p> <p>If no hyphen follows the first value, that value is assumed to be a single LU address. Multiple ranges can be entered, separated by commas. For example, the following string specifies 2 address ranges and 2 specific LU addresses:</p> <p style="padding-left: 40px;">2-40,56,58,100-250</p>
<b>Parameter</b>	Number of implicit workstation definitions
<b>Valid Values</b>	1 to 253
<b>Default Value</b>	1
<b>Description</b>	This parameter specifies the number of dependent LUs to be added to the implicit pool.

**add**

**lu**

This command adds a specific LU. You will be prompted to enter values for the following parameters. The parameter range will be shown in parentheses ( ). The parameter default will be shown in square brackets [ ].

## APPN Configuration Commands

Table 39. Configuration Parameter List - Add TN3270E LU

Parameter Information
<p><b>Parameter</b> LU name</p> <p><b>Valid Values</b> A string of 1 to 8 characters:</p> <ul style="list-style-type: none"> <li>• First character: A to Z, @, \$, and #</li> <li>• Second to eighth characters: A to Z, 0 to 9</li> </ul> <p><b>Default Value</b> None</p> <p><b>Description</b> This parameter specifies the LU name of the dependent LU being defined.</p>
<p><b>Parameter</b> NAU address</p> <p><b>Valid Values</b> 2 to 254</p> <p><b>Default Value</b> None</p> <p><b>Description</b> This parameter specifies the NAU address of the LU being defined.</p>
<p><b>Parameter</b> Station name</p> <p><b>Valid Values</b> A string of 1 to 8 characters:</p> <ul style="list-style-type: none"> <li>• First character: A to Z</li> <li>• Second to eighth characters: A to Z, 0 to 9</li> </ul> <p><b>Default Value</b> None</p> <p><b>Description</b> This parameter specifies the name representing either the link between the DLUR and the PU defined using the <b>add local-pu</b> command or the subarea link over which SNA data will flow.</p>

Table 39. Configuration Parameter List - Add TN3270E LU (continued)

<p><b>Parameter Information</b></p> <p><b>Parameter</b> Class</p> <p><b>Valid Values</b></p> <ul style="list-style-type: none"> <li>1 Explicit Workstation</li> <li>2 Implicit Workstation</li> <li>3 Explicit Printer</li> <li>4 Implicit Printer</li> </ul> <p><b>Default Value</b> 1</p> <p><b>Description</b> This parameter specifies the LU class.</p>
<p><b>Parameter</b> LU type</p> <p><b>Valid Values</b></p> <ul style="list-style-type: none"> <li>• 1 — 3270 Mod 2 display</li> <li>• 2— 3270 Mod 3 display</li> <li>• 3 — 3270 Mod 4 display</li> <li>• 4 — 3270 Mod 5 display</li> <li>• 5 — 3270 printer</li> <li>• 6 — SCS printer</li> </ul> <p><b>Default Value</b> 1</p> <p><b>Description</b> This parameter specifies the type of dependent LU for the LU being added.</p>
<p><b>Parameter</b> Implicit pool name</p> <p><b>Valid Values</b> A string of 1 to 8 characters:</p> <ul style="list-style-type: none"> <li>• First character: A to Z, &lt;</li> <li>• Second to eighth characters: A to Z, 0 to 9</li> </ul> <p><b>Default Value</b> &lt;DEFLT&gt;</p> <p><b>Description</b> This parameter specifies the name of the implicit pool to be used in the LU definition. This question is asked only if the <i>class</i> is an implicit workstation or implicit printer.</p>

## APPN Configuration Commands

Table 39. Configuration Parameter List - Add TN3270E LU (continued)

Parameter Information
<p><b>Parameter</b> Define an associated printer</p> <p><b>Valid Values</b> Yes or No</p> <p><b>Default Value</b> No</p> <p><b>Description</b> This parameter specifies whether you want to define an associated printer.</p>
<p><b>Parameter</b> Associated printer name</p> <p><b>Valid Values</b> A string of 1 to 8 characters:</p> <ul style="list-style-type: none"><li>• First character: A to Z, @, \$, and #</li><li>• Second to eighth characters: A to Z, 0 to 9</li></ul> <p><b>Default Value</b> None</p> <p><b>Description</b> This parameter specifies the name of the associated printer.</p>
<p><b>Parameter</b> Associated printer NAU address</p> <p><b>Valid Values</b> 2 to 254</p> <p><b>Default Value</b> None</p> <p><b>Description</b> This parameter specifies the NAU address for the associated printer LU definition.</p>

### Syntax:

add            map

This command adds a client IP address to LU name mapping. You will be prompted to enter values for the following parameters. The parameter range will be shown in parentheses ( ). The parameter default will be shown in square brackets [ ].

The following mapping rules apply:

- If a map definition contains a full subnet mask (255.255.255.255), indicating that the entry is for a specific client and a specific LU/pool is not requested by the client, any LU/pool in the map definition that matches the connection type may be tried.
- If a map definition does not contain a full subnet mask and a specific LU/pool is not requested, only pool entries in the map definition will be tried. You cannot create a definition that maps a subnet to a specific LU. You must map the subnet to a pool.

## APPN Configuration Commands

- For individual workstation LUs with associated printers, only the workstation LU is required to be in the map definition.
- If a connection request is received from a client and there are no map entries that match, the request will be rejected.
- A mixture of pool and LU types can be added to a particular map. The resource selected will be based on the type of connection request. The order in which the resources are defined in the map will be the order in which it is chosen for a particular connection request.
- The LU name cannot be mapped to the network IP address mapping.

**Note:** When a client connects while mapping is enabled, the server will begin ANDing the client's IP address with the subnet mask of each sequential map. The longest match between the incoming client IP address and the map definition determines which map definition is tried first. If all eligible resources in the map definition are in use, the map definitions are again searched for the next most specific match.

Table 40. Configuration Parameter List - Add TN3270E Map

Parameter Information
<p><b>Parameter</b> Client IP address or Network address</p> <p><b>Valid Values</b> Any valid IP address</p> <p><b>Default Value</b> 0.0.0.0</p> <p><b>Description</b> This parameter specifies the IP address of the client or network map definition to be added.</p>
<p><b>Parameter</b> Client IP address or Network address Mask</p> <p><b>Valid Values</b> Any valid IP address mask</p> <p><b>Default Value</b> 0.0.0.0</p> <p><b>Description</b> This parameter specifies the IP address mask of the client or network map definition to be added.</p>

## APPN Configuration Commands

Table 40. Configuration Parameter List - Add TN3270E Map (continued)

Parameter Information
<p><b>Parameter</b> Pool name/LU name</p> <p><b>Valid Values</b> A string of 1 to 8 characters:</p> <ul style="list-style-type: none"> <li>• First character: A to Z</li> <li>• Second to eighth characters: A to Z, 0 to 9</li> </ul> <p><b>Default Value</b> None</p> <p><b>Description</b> This parameter specifies an LU name or a Pool name to be mapped to the IP address. The LU name can only be mapped to a Host address. If the mask is a network mask, the name specified must be a pool name.</p>

### Syntax:

**add**            port

This command specifies additional port for the TN3270E Server to listen on. You will be prompted to enter values for the following parameters. The parameter range will be shown in parentheses ( ). The parameter default will be shown in square brackets [ ].

Table 41. Configuration Parameter List - Add TN3270E Port

<p><b>Parameter Information</b></p> <p><b>Parameter</b> Port number</p> <p><b>Valid Values</b> 1 to 65536</p> <p><b>Default Value</b> none</p> <p><b>Description</b> This parameter specifies the port number to be added.</p>
<p><b>Parameter</b> Support TN3270E?</p> <p><b>Valid Values</b> Yes or No</p> <p><b>Default Value</b> Yes</p> <p><b>Description</b> This parameter specifies whether the added port will negotiate to be a TN3270E server. If it is not an "E" Server, it will not support printing or system requests.</p>



## APPN Configuration Commands

Table 41. Configuration Parameter List - Add TN3270E Port (continued)

Parameter Information
<b>Parameter</b> Pool name
<b>Valid Values</b> A string of 1 to 8 characters: <ul style="list-style-type: none"><li>• First character: A to Z</li><li>• Second to eighth characters: A to Z, 0 to 9</li></ul>
<b>Default Value</b> None
<b>Description</b> This parameter specifies the name of the pool associated with this port. Clients that connect to this port and do not specify an LU name or pool name will be assigned an LU from this pool.

### Syntax:

**delete**            lu

This command removes a TN3270E LU. You will be prompted to enter values for the following parameters. The parameter range will be shown in parentheses ( ). The parameter default will be shown in square brackets [ ].

Table 42. Configuration Parameter List - Delete TN3270E LU

Parameter Information
<b>Parameter</b> LU name
<b>Valid Values</b> A string of 1 to 8 characters: <ul style="list-style-type: none"><li>• First character: A to Z, @, \$, and #</li><li>• Second to eighth characters: A to Z, 0 to 9</li></ul>
<b>Default Value</b> None
<b>Description</b> This parameter specifies the LU name of the dependent LU to be removed.

### Syntax:

**delete**            implicit-pool

This command removes a TN3270E implicit pool. You will be prompted to enter values for the following parameters. The parameter range will be shown in parentheses ( ). The parameter default will be shown in square brackets [ ].

## APPN Configuration Commands

Table 43. Configuration Parameter List - Delete TN3270E Implicit

Parameter Information
<p><b>Parameter</b> Pool name</p> <p><b>Valid Values</b> A string of 1 to 8 characters:</p> <ul style="list-style-type: none"><li>• First character: A to Z</li><li>• Second to eighth characters: A to Z, 0 to 9</li></ul> <p><b>Default Value</b> None</p> <p><b>Description</b> This parameter specifies the name of the LU pool to be deleted.</p>
<p><b>Parameter</b> Delete entire pool</p> <p><b>Valid Values</b> Yes or No</p> <p><b>Default Value</b> No</p> <p><b>Description</b> This parameter specifies whether the entire pool or a specific entry is to be deleted.</p>
<p><b>Parameter</b> Station name</p> <p><b>Valid Values</b> A string of 1 to 8 characters:</p> <ul style="list-style-type: none"><li>• First character: A to Z</li><li>• Second to eighth characters: A to Z, 0 to 9</li></ul> <p><b>Default Value</b> None</p> <p><b>Description</b> This parameter specifies the name of the station to be deleted.</p>

### Syntax:

delete            map

This command removes a client IP address to LU name mapping. You will be prompted to enter values for the following parameters. The parameter range will be shown in parentheses ( ). The parameter default will be shown in square brackets [ ].

Table 44. Configuration Parameter List - Delete TN3270E Map

Parameter Information
<p><b>Parameter</b> Client IP address or Network address</p> <p><b>Valid Values</b> Any valid IP address</p> <p><b>Default Value</b> 0.0.0.0</p> <p><b>Description</b> This parameter specifies the IP address of the client or network map definition to be deleted.</p>
<p><b>Parameter</b> Client IP address or Network address Mask</p> <p><b>Valid Values</b> Any valid IP address mask</p> <p><b>Default Value</b> 0.0.0.0</p> <p><b>Description</b> This parameter specifies the IP address mask of the client or network map definition to be deleted.</p>
<p><b>Parameter</b> Delete all entries for this client?</p> <p><b>Valid Values</b> Yes or No</p> <p><b>Default Value</b> No</p> <p><b>Description</b> This parameter specifies whether the entire pool or a specific name is to be deleted.</p>
<p><b>Parameter</b> Pool name</p> <p><b>Valid Values</b> A string of 1 to 8 characters:</p> <ul style="list-style-type: none"> <li>• First character: A to Z</li> <li>• Second to eighth characters: A to Z, 0 to 9</li> </ul> <p><b>Default Value</b> None</p> <p><b>Description</b> This parameter specifies the LU name or pool name to be deleted.</p>

**Syntax:**

**delete**            port

This command deletes port definitions. You will be prompted to enter values for the following parameters. The parameter range will be shown in parentheses ( ). The parameter default will be shown

## APPN Configuration Commands

in square brackets [ ].

Table 45. Configuration Parameter List - Delete TN3270E Port

Parameter Information
<b>Parameter</b> Port number
<b>Valid Values</b> 1 to 65536
<b>Default Value</b> none
<b>Description</b> This parameter specifies the port number to be added.

### Syntax:

list            all

This command lists a TN3270E configuration.

---

## Monitoring APPN

This section describes how to monitor APPN. It includes the following sections:

- “Accessing the APPN Monitoring Commands”
- “APPN Monitoring Commands” on page 191

---

## Accessing the APPN Monitoring Commands

Use the following procedure to access the APPN monitoring commands. This process gives you access to an APPN's *monitoring* process.

At the OPCON prompt, enter **talk 5**.

After you enter the **talk 5** command, the GWCON prompt (+) displays on the terminal. If the prompt does not appear when you first enter configuration, press **Return** again.

Enter **protocol APPN** For example:

```
* talk 5
+
+ protocol APPN
```

## APPN Monitoring Commands

This section describes the APPN monitoring commands for monitoring APPN interfaces. Enter the commands at the APPN> prompt.

Table 46. APPN Monitoring Command Summary

Command	Function
? (Help)	Displays all the commands available for this command level or lists the options for specific commands (if available). See “Getting Help” on page xxvi.
Aping	Pings an address
Dump	Creates an APPN dump file
List	Lists: <ul style="list-style-type: none"> <li>• CP-CP_sessions - displays information on CP-CP sessions.</li> <li>• ISR_sessions - displays information on active ISR transmission groups.</li> <li>• Session_information - If <i>Save RSCV information for intermediate nodes</i> is Yes, displays origin CP Name, primary LU Name, and secondary LU Name.</li> <li>• RTP_connections - displays information on RTP connections.</li> <li>• Port_information - displays information on all ports unless a particular interface is requested.</li> <li>• Link_information - displays information on all links unless a particular interface is requested.</li> <li>• Focal_point - displays currently active focal point.</li> <li>• Appc - displays information about APPC sessions.</li> <li>• Dumps - displays dump information.</li> <li>• Local-link</li> <li>• Log</li> <li>• Incomplete_locates</li> </ul>
Memory	Obtains and displays APPN memory usage information.
Restart	Restarts APPN
Stop	Stops APPN
TN3270	Accesses the TN3270 + command prompt from which you can display TN3270 configuration information. See Table 47 on page 193.
Transmit	Transmits a dump from the hardfile to a workstation in the network using tftp.
Exit	Returns you to the previous command level. See “Exiting a Lower Level Environment” on page xxvi.

## Aping

### Syntax:

**aping** *flags lu\_name*

where,

**flags** Specifies the options for the APING.

**-m** Mode name

**Default Value:** #INTER

**-t** TP name

**Default Value:** APING

## APPN Monitoring Commands

- i** Count of sends and receives to issue  
**Default Value:** 1
- x** Count of conversations to run  
**Default Value:** 1
- y** Count of TPs to run  
**Default Value:** 1
- s** Size of packet  
**Default Value:** 100
- q** Quiet
- b** Background display goes to talk 2

### **lu\_name**

Specifies the fully-qualified LU name of the target of the APING.

**Valid Values:** Any valid fully-qualified LU name

**Default Value:** None

## Dump

Use the **Dump** command to create APPN dump files to the hardfile, if there is a hardfile in the device. If the device does not have a hardfile, it will transfer the dump file to the server, which is defined using the talk 6 **set dump target** and **enable dump-memory** commands at the APPN> prompt.

### **Syntax:**

**dump**

## List

Use the **List** command to display information about the APPN configuration. The command lists:

### **Syntax:**

**list** *name*

<b>Command</b>	<b>Function</b>
----------------	-----------------

<b>List cp</b>	Displays a table of all cp sessions.
----------------	--------------------------------------

<b>List isr</b>	Displays a table of all defined active ISR transmission groups.
-----------------	---

<b>List session_info</b>	Displays origin CP Name, primary LU Name and secondary LU Name if <i>Save RSCV information for intermediate sessions</i> is Yes.
--------------------------	--

<b>List rtp</b>	Displays a table of all RTP connections.
-----------------	--

<b>List port</b>	Displays a summary table of all ports.
------------------	--

<b>List port</b> <i>port name</i>	Displays detailed information about the requested port.
-----------------------------------	---

<b>List link</b>	Displays a summary table of all links.
------------------	--

## APPN Monitoring Commands

- List link *station name***  
Displays detailed information about the requested link station.
- List focal** Displays currently active focal point, if there is one.
- List appc** Displays information about APPC sessions.
- List dumps** Displays information about the dumps saved on the hard file.
- List local\_link\_information**  
Displays information about local links.
- List routing\_list**  
Displays information about all configured routing lists.
- log** Displays the last 20 log entries.
- incomplete\_locates**  
Displays information on locates waiting for replies.

## Memory

Use the **Memory** command to display APPN memory usage information.

**Syntax:**

memory

## Restart

Use the **Restart** command to restart APPN after it has been stopped.

**Syntax:**

restart

## Stop

Use the **Stop** command to cause APPN to stop.

**Syntax:**

stop

## TN3270E

Use the **tn3270e** command to access the TN3270E> command prompt from which you can display information about the TN3270E configuration. See Table 47.

**Syntax:**

tn3270e

*Table 47. TN3270E Monitoring Command Summary*

Command	Function
? (Help)	Displays all the commands available for this command level or lists the options for specific commands (if available). See "Getting Help" on page xxvi.

## APPN Monitoring Commands

Table 47. TN3270E Monitoring Command Summary (continued)

Command	Function
List	Lists the following from configuration memory: <ul style="list-style-type: none"> <li>• Pools</li> <li>• Pools <i>pool name</i></li> <li>• Status</li> <li>• Connections</li> <li>• Connections <i>LU name</i></li> <li>• Connections <i>IP address</i></li> <li>• Maps</li> <li>• Ports</li> </ul>
Exit	Returns you to the previous command level. See “Exiting a Lower Level Environment” on page xxvi.

Command	Function
<b>List pools</b>	Displays a table of pools in the active state.
<b>List pools</b> <i>poolname</i>	Displays details about the specific pool name.
<b>List status</b>	Displays the status of the TN3270E Server.
<b>List connections</b>	Displays all the connections currently active.
<b>List connections</b> <i>ip address</i>	Displays all the connections currently active that originate from the specified IP address.
<b>List connections</b> <i>lu/pool name</i>	Displays all the connections currently active that are associated with the specified LU name or Pool name.
<b>List maps</b>	Displays the active client IP address to LU name mapping in the device.
<b>List ports</b>	Displays all active ports that the TN3270E Server is listening to.

## Transmit

Use the **Transmit** command to transmit an APPN dump from the hardfile to a workstation in the network using tftp.

### Syntax:

**transmit** *dump-number*



---

## Chapter 3. Using AppleTalk Phase 2

This chapter describes the AppleTalk Phase 2 (AP2) configuration commands and includes the following sections:

- “Basic Configuration Procedures”
- “AppleTalk 2 Zone Filters” on page 196
- “Sample Configuration Procedures” on page 198

---

### Basic Configuration Procedures

This section outlines the initial steps required to get the AppleTalk Phase 2 protocol up and running. Information on how to make further configuration changes will be covered in the command sections of this chapter. For the new configuration changes to take effect, the router must be restarted.

#### Enabling Router Parameters

When you configure a router to forward AppleTalk Phase 2 packets, you must enable certain parameters regardless of the number or type of interfaces in the router. If you have multiple routers transferring AppleTalk Phase 2 packets, specify these parameters for each router.

- Globally Enable AppleTalk Phase 2 - To begin, you must globally enable the AppleTalk Phase 2 software using the AppleTalk Phase 2 configuration **enable ap2** command. If the router displays an error in this step, there is no AppleTalk Phase 2 software present in your load. If this is the case, contact your customer service representative.
- Enable Specific Interfaces - You must then enable the specific interfaces over which AppleTalk Phase 2 is to send the packets. Use the **enable interface interface number** command to do this.
- Enable Checksumming - You can then determine whether the router will compute DDP checksums of packets it originates. Checksum software does not work correctly in some AppleTalk Phase 2 implementations, so you may not want to originate packets with checksums for compatibility with these implementations. Normally, however, you will want to enable the generation of checksums. Any packet forwarded with a checksum will have its checksum verified.

#### Setting Network Parameters

You must also specify certain parameters for each network and interface that sends and receives AppleTalk Phase 2 packets. After you have specified the parameters, use the AppleTalk Phase 2 list configuration command to view the results of the configuration.

- Set the Network Range for Seed Routers - Coordinating network ranges and zone lists for all routers on a network is simplified by having specific routers designated as seed routers. Seed routers are configured with the network range and zone list while all other routers are given null values. Null values indicate that the router should query the network for values from the seed routers. For every network (segment) of your interconnected AppleTalk internet, at least one router interface must be configured as the seed router for that network. There are usually several seed routers on a network in case one of them fails. Also, a

## Using AppleTalk Phase 2

router can be a seed router for some or all of its network interfaces. Use the **set net-range** command to assign the network range in seed routers.

- Set the Starting Node Number - Use the **set node** command to assign the starting node number for the router. The router will AARP for this node, but if it is already in use, a new node will be chosen.
- Add a Zone Name - You can add one or more zone names for each network in the internetwork. You can add a zone name for a given network in any router connected to that network; however, only the seed router needs to contain the zone name information for a connected network. Attached routers dynamically acquire the zone name from adjacent routers using the ZIP protocol. Apple recommends that, for a given network, you choose the same seed router for the network number and the zone name. The zone name cannot be configured for a network unless the network number is also configured. To add a zone name for each network number, use the AppleTalk Phase 2 configuration **add zone name** command.

---

## AppleTalk over PPP

There are two modes for AppleTalk over PPP, full-router and half-router. In full-router mode, the point-to-point network is visible to other AppleTalk routers. In half-router mode, the point-to-point network is invisible to other routers, but it still transmits AppleTalk routing information and data packets.

To set up your network for full-router mode, give each router on the PPP link a common network number, a common zone name, and a unique node number. If you configure one end of the PPP link with a non-zero network number, you must also configure that end to have a non-zero node number and to have a zone name. In this case, the other end of the link must have either:

- The same network number and zone name and a different node number.
- Network and node numbers set to zero. The router will learn network and node numbers from the configured router.

To set up your network for half-router mode, configure both routers on the PPP link so that network and node numbers are set to zero and no zone name is used.

---

## AppleTalk 2 Zone Filters

ZoneName filtering, although not required for AppleTalk, is a very desirable feature for the security and administration of large AppleTalk Internetworks. There are also provisions for restricting access to networks by net numbers.

## General Information

AppleTalk is structured so that every network is identified in two ways. The first is a network number or range of consecutive network numbers that must be unique throughout the internet. The network number combined with the node number uniquely identifies any end station in the internet.

The second identifier for the network is one or more ZoneNames. These ZoneName strings are not unique throughout the internet. The end station is uniquely identified by a combined **object:type:ZoneName-string**.

A router first learns about a network when the new net range appears in the RTMP routing update from a neighboring router. The router then queries the neighbor for

the ZoneNames of the new network. Note that the net range is repeated in every new RTMP update but that the ZoneNames are requested only once.

The end stations obtain the network numbers from the broadcasted RTMP (routing information) packets and then choose a node number. This net/node pair is then AARP'd for (AARP Probe) to see if any other end station has already claimed its use. If another station responds, another net/node pair is chosen by the end station and the process repeated until no responses are received.

### Why ZoneName Filters?

When the typical AppleTalk end station wants to use a service (printer, file server) on the Apple Internet, it first looks at all available Zones and selects one. It then chooses a service type and requests a list of all names advertising the type in the chosen Zone. Several problems arise from this mechanism.

- A large internet may have many Zones. Presenting the user with a long list to choose from obscures the needed ones (thereby inhibiting usability of the list).
- The server may not want to make itself available throughout the internet (for security reasons). If the Zone that the service is in is not visible to the client, security is enhanced.
- Restricting the Zones that are visible from a department to the rest of the internet will allow the internet administration to let the department control (or not) its own domain while not increasing the overhead for the rest of the internet (reducing administration).

The filtering of network numbers further enhances the security and administration of the internet. Network access is only indirectly controlled by Zone filtering. An unregulated department could add networks with the same Zone names but new net numbers that conflict with other departments. Network number filtering can be used to prevent these random additions of zone names and net numbers from impacting the rest of the network.

### How Do You Add Filters?

The router is configured with an exclusive (meaning block the specified zones) or inclusive (meaning allow only these zones) list of Zones for each direction on each interface. The specified interface will not readvertise filtered Zone information in the defined direction. If all Zones in a network's Zonelist are filtered, network information will also be filtered across the interface.

- Use configuration commands **add** and **delete**, to create the filter list for an interface.
- Use configuration commands **enable** and **disable** to specify how the filter list is applied.

Use similar commands to create network number filters.

#### Other Commands:

You can use the AP2 CONFIG> **list** command to display all filter information for the interfaces. In addition, the **list** command accepts an *interface#* as an argument so that you can list information for only an interface.

## Using AppleTalk Phase 2

### Sample Configuration Procedures

This section covers the steps required to get AP2 up and running. For information on how to make further configuration changes, see “AppleTalk Phase 2 Configuration Commands” on page 203. For the configuration changes to take effect, you must restart the router.

To access the AP2 configuration environment, enter **protocol ap2** at the Config> prompt.

#### Enabling AP2

When you configure a router to forward AP2 packets, you must enable certain parameters. If you have multiple routers transferring AP2 packets, specify these parameters for each router. To enable AP2:

1. Use the **enable ap2** command to globally enable AP2 on the router. For example:

```
AP2 config>enable ap2
```

2. Enable the specific interfaces over which AP2 is to send packets. For example:

```
AP2 config>enable interface 1
```

#### Setting Network Parameters

To set up your router as a seed router, you must set the network range, a starting node number, and at least one zone name. You can configure some interfaces on a router as seed routers and leave other interfaces as non-seed routers. You must have at least one seed router for each AppleTalk network, and you should configure several seed routers on a network in case one of them fails.

**Note:** Do not set a network range or a node number for half routers.

1. Use the **set net-range** command to set the Network Range. For example:

```
AP2 config>set net-range
Interface # [0]? 1
First Network range number (1-65279, or 0 to delete) []? 1
Last Network range number (1-165279) []? 5
```

Enter the same first and last values for a single-numbered network.

2. Use the **set node-number** command to set the Starting Node Number for the interface. The router will AARP for this node. If the number is already in use, the router will choose a new number. For example:

```
AP2 config>set node-number
Interface # [0]? 1
Node number (1-253, or 0 to delete) []? 1
```

3. Use the **add zone** command to add one or more zone names for the network attached to the interface. If you define a network range for an interface, you should also define the zone names for the interface. If you did not define a network number, do not define zone names. For example:

```
AP2 config>add zone
Interface # [0]? 1
Zone name []? Finance
```

After you have specified the parameters, you can use the **list** command at the AP2 config> prompt to view your configuration.

## Setting Up Zone Filters

Zone filtering lets you filter zones in each direction on each interface. To filter incoming packets, set up an input filter. To filter outgoing packets, set up an output filter. The interface will not readvertise filtered zone information in the direction that you define. Follow these steps to set up a zone filter:

1. Add zone filters to an interface. Use the **add zfilter in** command to add an input zone filter to an interface. Use the **add zfilter out** command to add an output zone filter to an interface. For example:

```
AP2 config>add zfilter in
Interface # [0]? 1
Zone name []? Admin
```

2. Enable the zone filters that you added. This turns on the filter and controls whether the filter is inclusive or exclusive. Inclusive filters forward only the zone information in that filter. Exclusive filters block only the zone information in that filter. For example:

```
AP2 config>enable zfilter in exc
Interface # [0]? 1
```

The following are some examples that explain how to set up zone filters in the internet shown in Figure 12.

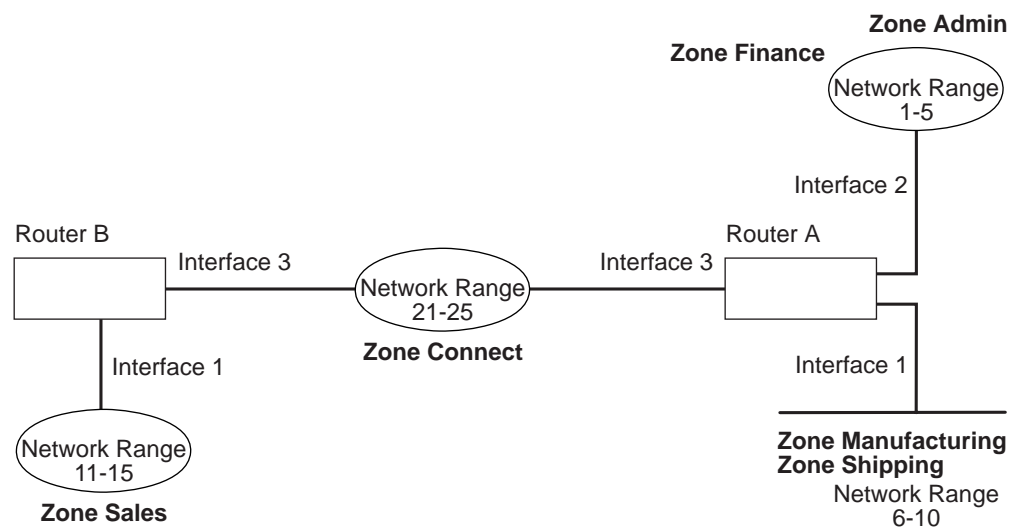

Figure 12. Example of Zone Filtering

### Example 1

The following is an example of how to filter the Manufacturing zone from all other networks. To do this, you would set up an input filter on Interface 1 of Router A to exclude the Manufacturing zone.

1. On Router A, add an input zone filter to Interface 1.

```
AP2 config>add zfilter in
Interface # [0]? 1
Zone name []? Manufacturing
```

2. Enable the input zone filter and make the filter exclusive.

```
AP2 config>enable zfilter in exc
Interface # [0]? 1
```

This excludes Manufacturing zone information from entering Router A, thereby filtering the zone from the rest of the internet.

## Using AppleTalk Phase 2

### Example 2

The following example shows how to filter the Manufacturing zone from Network 11-15, but still allow the Manufacturing zone to be visible on Network 1-5. To do this, you would set up an output filter on Interface 3 of Router A to exclude Manufacturing zone information from being forwarded out of Interface 3. The interface will continue to advertise Manufacturing zone information over interfaces 1 and 2 on Router A, making it visible on Network 1-5.

1. Add an output zone filter to Interface 3.

```
AP2 config>add zfilter out
Interface # [0]? 3
Zone name []? Manufacturing
```

2. Enable the output zone filter and make the filter exclusive.

```
AP2 config>enable zfilter out exc
Interface # [0]? 3
```

This filter excludes Manufacturing zone information from the output of Interface 3.

### Example 3

The next example shows how to set up a filter so that the Admin zone is visible on all networks, but the Finance zone is not visible to the rest of the internet.

1. Add an input zone filter to Interface 2 on Router A.

```
AP2 config>add zfilter in
Interface # [0]? 2
Zone name []? Admin
```

2. Enable the input zone filter and make it inclusive.

```
AP2 config>enable zfilter in inc
Interface # [0]? 2
```

By setting up this input filter as inclusive, only Admin zone information is forwarded through Interface 2 to the rest of the internet.

## Setting Up Network Filters

Network filters are similar to zone filters, except they let you filter an entire network. To set up a network filter:

1. Add a network filter. Use the **add nfilter in** command to add an input network filter to an interface. Use the **add nfilter out** command to add an output network filter to an interface. For example:

```
AP2 config>add nfilter out
Interface # [0]? 2
First Network range number (decimal) [0]? 11
Last Network range number (decimal) [0]? 15
```

The network range you enter here must match the range that you assigned to that network.

2. Enable the network filter that you added and make it either inclusive or exclusive. Inclusive filters forward only network information in that filter. Exclusive filters block only network information in a filter, and they allow all other network information to be forwarded.

```
AP2 config>enable nfilter in exc
Interface # [0]? 2
```

Following are some examples that explain how to set up network filters in the internet, as shown in Figure 13 on page 201.

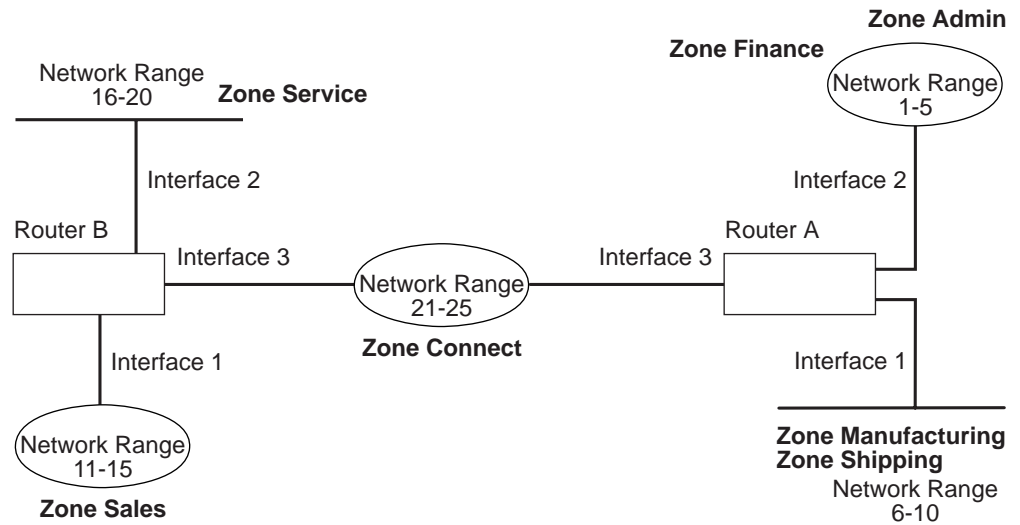

Figure 13. Example of Network Filtering.

The following steps show how to filter Network 6-10 so that it is not visible to Network 16-20 as shown in Figure 13.

1. Add an output network filter for Network 6-10 to Interface 2 on Router B.

```
AP2 config>add nfilter out
Interface # [0]? 2
First Network range number (decimal) [0]? 6
Last Network range number (decimal) [0]? 10
```

2. Enable the output network filter as exclusive.

```
AP2 config>enable nfilter out exc
Interface # [0]? 2
```

This filter excludes all information on Network 6-10 from being forwarded through Interface 2 to Network 16-20.

## Using AppleTalk Phase 2



---

## Chapter 4. Configuring and Monitoring AppleTalk Phase 2

This chapter describes the AppleTalk Phase 2 (AP2) configuring and monitoring commands. It includes the following sections:

- “Accessing the AppleTalk Phase 2 Configuration Environment”
- “AppleTalk Phase 2 Configuration Commands”
- “Accessing the AppleTalk Phase 2 Monitoring Environment” on page 211
- “AppleTalk Phase 2 Monitoring Commands” on page 211

---

### Accessing the AppleTalk Phase 2 Configuration Environment

To access the AppleTalk Phase 2 configuration environment, enter the following command at the Config> prompt:

```
Config> ap2
AP2 Protocol user configuration
AP2 Config>
```

---

### AppleTalk Phase 2 Configuration Commands

This section describes the AppleTalk Phase 2 configuration commands.

The AppleTalk Phase 2 configuration commands allow you to specify network parameters for router interfaces that transmit AppleTalk Phase 2 packets. The information you specify with the configuration commands becomes activated when you restart the router.

Enter the AppleTalk Phase 2 configuration commands at the AP2 config> prompt. Table 48 shows the commands.

*Table 48. AppleTalk Phase 2 Configuration Commands Summary*

Command	Function
? (Help)	Displays all the commands available for this command level or lists the options for specific commands (if available). See “Getting Help” on page xxvi.
Add	Adds zone names, network filters, and zone filters to an interface.
Delete	Deletes the zone names, interfaces, network filters, and zone filters.
Disable	Disables interfaces, checksumming, split-horizon routing, network filters, or zone filters, or globally disables AppleTalk Phase 2.
Enable	Enables interfaces, checksumming, split-horizon routing, network filters, zone filters, or globally enables AppleTalk Phase 2.
List	Displays the current AppleTalk Phase 2 configuration.
Set	Sets the cache size, network range, and node number.
Exit	Returns you to the previous command level. See “Exiting a Lower Level Environment” on page xxvi.

## AppleTalk Phase 2 Configuration Commands (Talk 6)

### Add

Use the **add** command to add the zone name to the interface zone list or to add the zone name to the interface zone list as the default for the interface or to add network and zone filters.

#### Syntax:

```
add zone . . .  
defaultzone . . .  
nfilter in . . .  
nfilter out . . .  
zfilter in . . .  
zfilter out . . .
```

#### **zone** *interface# zonename*

Adds the zone name to the interface zone list. If you define a network number for an interface, you should also define the zone names for the interface. If you did not define a network number, do not define zone names.

#### Example:

```
ap2config>add zone  
Interface # [0]? 0  
Zone name []? Finance
```

#### **defaultzone** *interface# zonename*

Adds a default zone name for the interface. If a node on the network requests a zone name that is invalid, the router assigns the default zone name to the node until another zone name is chosen. If you add more than one default to an interface, the last one added overrides the previous default. If you do not add a default, the first zone name added using the **zone** command is the default.

#### Example:

```
ap2config>add defaultzone  
Interface # [0]? 0  
Zone name []? Headquarters
```

#### **nfilter in** *interface# first network# last network#*

Adds a network filter to the input of the interface. The network range that you enter must match the network range you set for that interface. You cannot filter only a portion of a network range. For example, if you set a network range of 1–10, and you set up a filter for 5–8, the router filters the full network range of 1–10.

#### Example:

```
ap2config>add nfilter in  
Interface # [0]? 0  
First Network range number (decimal) [0]? 1  
Last Network range number (decimal) [0]? 10
```

#### **nfilter out** *interface# first network# last network#*

Adds a network filter to the output of the interface. The network range that you enter must match the network range you set for that interface. You cannot filter only a portion of a network range. For example, if you set a network range of 1–10, and you set up a filter for 5–8, the router filters the full network range of 1–10.

#### Example:

## AppleTalk Phase 2 Configuration Commands (Talk 6)

```
ap2config>add nfilter out
Interface # [0]? 0
First Network range number (decimal) [0]? 11
Last Network range number (decimal) [0]? 20
```

### **zfilter in** *interface# zone name*

Adds a zone name filter to the input or output of the interface.

#### **Example:**

```
ap2config>add zfilter in
Interface # [0]? 1
Zone name []? Marketing
```

### **zfilter out** *interface# zone name*

Adds a zone name filter to the output of the interface.

#### **Example:**

```
ap2config>add zfilter out
Interface # [0]? 0
Zone name []? Corporate
```

## Delete

Use the **delete** command to delete a zone name from the interface zone list, network or zone name filters, or all AppleTalk Phase 2 information from an interface.

### **Syntax:**

```
delete           zone . . .
                  nfilter in . . .
                  nfilter ot . . .
                  zfilter in . . .
                  zfilter ot . . .
                  interface
```

### **zone** *interface# zonename*

Deletes a zone name from the interface zone list.

#### **Example:**

```
ap2config>delete zone 2 newyork
```

### **nfilter in** *interface# first network# last network#*

Deletes a network filter from the input of the interface. You must enter the same network range numbers you set using the **add nfilter in** command.

#### **Example:**

```
ap2config>delete nfilter in
Interface # [0]? 0
First Network range number (decimal) [0]? 1
Last Network range number (decimal) [0]? 12
```

### **nfilter out** *interface#*

Deletes a network filter from the output of the interface. You must enter the same network range numbers you set using the **add nfilter out** command.

#### **Example:**

```
ap2config>delete nfilter out
Interface # [0]? 0
First Network range number (decimal) [0]? 11
Last Network range number (decimal) [0]? 20
```

### **zfilter in** *interface# zone name*

Deletes a zone name filter from the input of the interface.

## AppleTalk Phase 2 Configuration Commands (Talk 6)

### Example:

```
ap2config>delete nfilter in
Interface # [0]? 1
Zone name []? Marketing
```

### **zfilter out** *interface# zone name*

Deletes a zone name filter from the output of the interface.

### Example:

```
delete zfilter out
Interface # [0]? 1
Zone name []? Marketing
```

### **interface**

Use this command to delete an interface. This is the only way to delete zone names that have non-printing characters.

### Example:

```
ap2config>delete interface 1
```

## Disable

Use the **disable** command to disable AP2 on all interfaces or on a specified interface, checksumming, filtering, APL/AP2 translation, or split horizon routing.

### Syntax:

```
disable                ap2
                        checksum
                        interface . . .
                        nfilter in . . .
                        nfilter out . . .
                        zfilter in . . .
                        zfilter out . . .
                        split-horizon-routing . . .
```

**ap2** Disables the AppleTalk Phase 2 packet forwarder for all interfaces.

### Example:

```
ap2config>disable ap2
```

### **checksum**

Specifies that the router will not compute the checksum in packets it generates. The router usually checksums all packets it forwards. This is the default.

### Example:

```
ap2config>disable checksum
```

### **interface** *interface#*

Disables all AP2 functions on the specified network interface. The network continues to remain available for all other protocols.

### Example:

```
ap2config>disable interface 2
```

### **nfilter in** *interface#*

Disables, but does not delete, the input network filters on this interface.

## AppleTalk Phase 2 Configuration Commands (Talk 6)

### Example:

```
ap2config>disable nfilter in  
Interface # [0]? 2
```

### **nfilter out** *interface#*

Disables, but does not delete, the output network filters on this interface.

### Example:

```
ap2config>disable nfilter out  
Interface # [0]? 2
```

### **zfilter in** *interface#*

Disables, but does not delete, the input zone filters on this interface.

### Example:

```
ap2config>disable zfilter in  
Interface # [0]? 1
```

### **zfilter out** *interface#*

Disables, but does not delete, the output zone filters on this interface.

### Example:

```
ap2config>disable zfilter out 0  
Interface # [0]? 1
```

### **split-horizon-routing** *interface#*

Disables split-horizon-routing on this interface. You need to disable split-horizon routing only on Frame Relay interfaces that are on a hub in a partially-meshed Frame Relay network. Disabling split-horizon routing causes all of the routing tables to be propagated on this interface.

### Example:

```
ap2config>disable split-horizon-routing 0
```

## Enable

Use the **enable** command to enable the checksum function, to enable a specified interface, to enable AppleTalk 2 gateway function, or to globally enable the AppleTalk Phase 2 protocol.

### Syntax:

```
enable                ap2  
                        checksum  
                        interface . . .  
                        nfilter in . . .  
                        nfilter out . . .  
                        split-horizon-routing . . .  
                        zfilter . . .
```

**ap2** Enables the AppleTalk Phase 2 packet forwarder over all of the interfaces.

### Example:

```
ap2config>enable ap2
```

### **checksum**

Specifies that the router will compute the checksum in packets it generates. The router checksums all AP2 packets it forwards.

### Example:

## AppleTalk Phase 2 Configuration Commands (Talk 6)

```
ap2config>enable checksum
```

### **interface** *interface#*

Enables the router to send AppleTalk Phase 2 packets over specific interfaces.

#### **Example:**

```
ap2config>enable interface 3
```

### **nfilter in** *exclusive or exclusive interface#*

Enables network input filters and controls how the filter is applied to the interface. Inclusive forwards matches. Exclusive drops matches.

#### **Example:**

```
ap2config>enable filter in inc
Interface # [0]? 1
```

### **nfilter out** *exclusive or exclusive interface#*

Enables network output filters and controls how the filter is applied to the interface. Inclusive forwards matches. Exclusive drops matches.

#### **Example:**

```
ap2config>enable filter out exec
Interface # [0]? 1
```

### **split-horizon-routing** *interface #*

Enables split-horizon routing on the interface. The default is *enabled*.

#### **Example:**

```
ap2config>enable split-horizon-routing 1
```

**zfilter** Enables zone filters assigned to an interface. Must specify if filter is "in" or "out" and if the filter is inclusive or exclusive. Inclusive means that only packets matching the filter will be routed. Exclusive means that all packets matching the filter will be discarded.

#### **Example:**

```
ap2config>enable zfilter in inc
Interface # [0]?
```

#### **Example:**

```
ap2config>enable zfilter out exec
Interface # [0]? 0
```

## List

Use the **list** command to display the current AP2 configuration. In the example, the router is a seed router on interfaces 0 and 1

**Note:** The **list** command accepts an *interface#* as an argument.

### **Syntax:**

```
list
```

### **Example:**

```
ap2config>list
APL2 globally enabled
Checksumming disabled
Cache size 500
```

List of configured interfaces:

Interface	netrange	/	node	Zone
0	1000-1000	/	1	"SerialLine"(Def)

## AppleTalk Phase 2 Configuration Commands (Talk 6)

```
Input ZFilters disabled
Input NFilters (inclusive)
Output ZFilters disabled
Output NFilters disabled
Split-horizon-routing enabled
1      10-19      / 52 "EtherTalk", "Sales"(Def)
Input ZFilters disabled
Input NFilters (inclusive)
Output ZFilters disabled
Output NFilters disabled
Split-horizon-routing enabled
2      unseeded net / 0
Input ZFilters disabled
Input NFilters (inclusive)
Output ZFilters disabled
Output NFilters disabled
Split-horizon-routing disabled
```

### APL2 globally

Indicates whether AppleTalk Phase 2 is globally enabled or disabled.

### Checksumming

Indicates whether checksum is enabled or disabled.

### Cache size

Number of fastpath cache entries.

### List of configured interfaces

Lists each interface number and its network range, node number, and zone name(s) as well as the default zone.

For each interface also lists whether or not input and output zone filters and network filters are enabled or disabled. If they are enabled, indicates whether or not they are inclusive or exclusive.

### Input/output Zfilters

Indicates zone filters assigned to an interface. Inclusive means that only packets matching the filter will be routed. Exclusive means that all packets matching the filter will be discarded. The name of the zone filtered is displayed. Input means that the filter is applied to traffic coming into the interface. Output means that filter is applied to traffic going out to the interface.

### Input/output Nfilters

Indicates net filters assigned to an interface. Inclusive means that only packets matching the filter will be routed. Exclusive means that all packets matching the filter will be discarded. The range of networks filtered is displayed. Input means that the filter is applied to traffic coming into the interface. Output means that filter is applied to traffic going out to the interface.

### Split-horizon-routing

Shows whether or not split-horizon routing is enabled or disabled on each interface.

## Set

Use the **set** command to define the cache-size of fastpath or specific AppleTalk Phase 2 parameters, including the network range in seed routers and the node number.

### Syntax:

```
set          cache-size . . .
              net-range . . .
```

## AppleTalk Phase 2 Configuration Commands (Talk 6)

node . . .

### **cache-size** *value*

*Cache-size* corresponds to the total number of AppleTalk networks and nodes that can simultaneously communicate through this router using the fastpath feature. (Fastpath is a method of precalculating MAC headers to forward packets more quickly.) The default is 500, which allows up to 500 networks and nodes to simultaneously communicate through the router and still use fastpath. If the number of networks and nodes becomes greater than the cache size, the router still forwards the packets, but it does not use fastpath. Valid values for cache size are: 0 (disable), 100 to 10 000. Although not recommended, setting the cache-size to zero disables the fastpath feature and no memory is used for the cache. You need to change this default only for very large networks. Each cache-size entry uses 36 bytes of memory.

#### **Example:**

```
ap2config>set cache-size 700
```

### **net-range** *interface# first# last#*

Assigns the network range in seed routers using the following:

- *interface#* - Designates the router interface to operate on.
- *first#* - Assigns the lowest number of the network range. Legal values are 1 to 65279 (10xFEFF hexadecimal).
- *last#* - Sets the highest number of the network range. Legal values are *first#* to 65279.

A single numbered network has the same first and last values. A first value of zero deletes the netrange for the interface and turn the “seeded” interface into an “unseeded” interface. *First#* and *last#* are inclusive in the network range.

Setting the first value to zero on a Point-to-Point (PPP) interface allows that interface to operate in “half-router” mode. In half-router mode, neither of the two ends of a PPP network is configured with a network range or a zone list which reduces the amount of configuration needed. Both routers on a PPP network must operate in the same mode.

**Note:** When connecting a 2212 to an IBM 6611 using a PPP interface, set the 2212 for “half-router” mode which is the *only* mode of operation supported by the IBM 6611 for AppleTalk communications over a PPP interface.

#### **Example:**

```
ap2config>set Net-Range 2 43 45
```

### **node** *interface# node#*

Assigns the starting node number for the router. The router will AARP for this node but if it is already in use, a new node will be chosen. The following explains each argument that is entered after this command:

- *interface#* - Designates the router interface to operate on.
- *node#* - Designates the first attempted node number. Legal values are 1 to 253. A *node#* value of zero deletes the node number for the interface and forces the router to choose one at random.

#### **Example:**



```
ap2config>set node 2 2
```

---

### Accessing the AppleTalk Phase 2 Monitoring Environment

To access the AppleTalk Phase 2 monitoring environment, enter the following command at the + (GWCON) prompt:

```
+ protocol ap2
AP2>
```

---

### AppleTalk Phase 2 Monitoring Commands

This section describes the AppleTalk Phase 2 monitoring commands which allow you to view the parameters and statistics of the interfaces and networks that transmit AppleTalk Phase 2 packets. Monitoring commands display configuration values for the physical, frame, and packet levels. You also have the option of viewing the values for all three protocol levels at once.

Enter the AppleTalk Phase 2 monitoring commands at the AP2> prompt. Table 49 shows the commands.

*Table 49. AppleTalk Phase 2 Monitoring Command Summary*

Command	Function
? (Help)	Displays all the commands available for this command level or lists the options for specific commands (if available). See “Getting Help” on page xxvi.
Atecho	Sends echo requests and watches for responses.
Cache	Displays the cache table entries.
Clear	Clears all cache usage counters and packet overflow counters.
Counters	
Counters	Displays the overflow count of AP2 packets for each interface.
Dump	Displays the current state of the routing table for all networks in the internet and their associated zone names.
Interface	Displays the current addresses of the interfaces.
Exit	Returns you to the previous command level. See “Exiting a Lower Level Environment” on page xxvi.

### Atecho

The **atecho** command sends AppleTalk Echo Requests to a specified destination and watches for a response. This command can be used to verify basic AppleTalk connectivity and to isolate trouble in the AppleTalk internetwork.

#### Syntax:

```
atecho dest_net dest_node
```

#### **dest\_net**

Specifies the destination AppleTalk network number, in decimal. This is a required parameter.

#### **dest\_node**

Specifies the destination AppleTalk node number, in decimal. This is a required parameter.

## AppleTalk Phase 2 Monitoring Commands (Talk 5)

**Note:** For many AppleTalk nodes, the network address (network number and node number) is dynamically assigned and might not be readily available. However, there are still a number of ways to use the **atecho** command effectively:

1. The AppleTalk address for router nodes is statically configured in many cases. Connectivity between router nodes is critical to overall network connectivity.
2. By setting the **atecho** destination node number to 255, you can query all nodes on the specified network number on a directly attached AppleTalk network. The received responses will indicate the node's node number. These node numbers can then be used to echo these nodes from distant routers to verify connectivity.

### **src\_net**

Source AppleTalk network number. This is an optional parameter. If not specified, the router uses its interface network number on the outgoing interface leading to the destination network. If the outgoing interface is an unnumbered half-router PPP interface, the router uses any one of its LAN interface network nodes.

### **src\_node**

Source AppleTalk node number. This is an optional parameter. If not specified, the router uses its interface node number on the outgoing interface leading to the destination network. If the outgoing interface is an unnumbered half-router PPP interface, the router uses any one of its LAN interface network nodes.

**size** Number of bytes to use in the AppleTalk echo requests. This is an optional parameter. Default is 56 bytes.

**rate** Rate of sending AppleTalk echo requests. This is an optional parameter. Default is one second.

**Note:** If you enter **atecho** with no parameters, you are prompted for all the parameters. Enter values for the required parameters and either enter values for the optional parameters or accept defaults.

## Cache

The **cache** command displays information about the cache-size entries.

### **Syntax:**

#### **cache**

#### **Example: cache**

Destination	Interface	Usage	Next Hop
122/22	1	1	27/5
138/51	0	1	27/5
23/7	1	1	Direct

### **Destination**

AppleTalk node address (network number/node number).

**Net** Number of the interface used to forward to the destination node.

**Usage** Number of times this cache entry has been used in this aging period, which is five seconds. An unused entry is deleted after 10 seconds.

## AppleTalk Phase 2 Monitoring Commands (Talk 5)

### Next Hop

The AppleTalk address of the next hop router used to forward a packet to the destination node, or Direct if the destination node is directly connected to the interface.

## Clear Counters

The clear-counters command clears all cache usage counters and packet overflow counters.

### Syntax:

clear-counters

## Counters

Use the **counters** command to display the number of packet overflows on each network that sends and receives AppleTalk Phase 2 packets. This command displays the number of times the AppleTalk Phase 2 forwarder input queue was full when packets were received from the specified network.

### Syntax:

counters

### Example: counters

```
AP2 Input Packet Overflows
Net          Count
FR/0         0
Eth/0        4
PPP/0        22
```

## Dump

Use the **dump** command to obtain routing table information about the interfaces on the router that forwards AppleTalk Phase 2 packets.

**Note:** dump *interface#* displays the part of the overall network and zone information that is visible on that interface.

### Syntax:

dump

### Example: dump

```
Dest Net    Cost    State  Next hop    Zone
10-19       0       Dir   0/0         "Ethertalk", "Sales"
40-49       1       Good  10/13       "Marketing", "CustomerSer",
              "TokenTalk"
20-29       2       Sspct 10/13       "Fuchsia", "Backbone",
              "Engineering", "MKTING"

3 entries
```

You can also use the **dump** command with a specific interface to display the routes that are visible on that interface. You can use this feature to make sure filters are configured correctly because it shows whether or not filtered zones or networks are visible to an interface.

## AppleTalk Phase 2 Monitoring Commands (Talk 5)

### Example: dump 0

```
View for interface 0

Dest net  Cost  State  Next hop  Zone
214-214   1    Good   152/152  "eth-214"
153-153   0    Dir              "eth153"
152-152   0    Dir              "ser152"

3 entries
```

### Dest Net

Specifies the destination network number, in decimal.

**Cost** Specifies the number of router hops to this destination network.

**State** Specifies the state of the entry in the routing table. It includes the following:

### Next hop

Specifies the next hop for packets going to networks that are not directly connected. For directly-connected networks, this is node number 0.

### Zone(s)

Specifies the human-understandable name for that network. The zone name(s) is enclosed in double quotes in case there are embedded spaces or non-printing characters. If the zone name contains characters beyond the 7-bit ASCII character set (they are 8-bit), the zone name that displays will depend on the characteristics of your monitoring terminal.

## Interface

Use the **interface** command to display the addresses of all the interfaces in the router on which AppleTalk Phase 2 is enabled. If the interface is present in the router but is disabled, this command shows that status.

**Note:** `interface interface#` displays the active filtering for that interface. It displays net, node, default zone, and active filters for one interface.

### Syntax:

**interface**  
\_

### Example: interface

```
Interface  Addresses
PPP/0     0/1 on net 1000-1000  default zone "Serial Line"
Eth/0     10/52 on net 10-19   default zone "Sales"
PPP/1     0/0 in startup range
TKR/0     0/0 on net 20-29 default zone "Backbone"
```

You can also enter the interface command followed by a specific interface number to view the AP2 configuration of that interface.

### Example: interface 1

```
Eth/0  1/30 on net 1-5  default zone "marketing"

Input Net filters inclusive  1-5
Output Zone filters inclusive "finance"
Output Net filters exclusive 1-5
```

---

## Chapter 5. Using VINES

This chapter describes the commands to configure the Banyan VINES protocol and includes the following sections:

- “VINES Overview”
- “VINES Network Layer Protocols” on page 216
- “Basic Configuration Procedures” on page 221
- “Accessing the VINES Configuration Environment” on page 223
- “Running Banyan VINES on the Bridging Router” on page 221
- “VINES Configuration Commands” on page 223.

**Note:** If you need more detailed information on VINES Protocols, consult the Banyan publication: *VINES Protocol Definition*, order number: 003673

---

### VINES Overview

#### VINES Over Router Protocols and Interfaces

The VINES protocol routes VINES packets over the following interfaces and protocols:

- PPP Banyan Vines Control Protocol (PPP BVCP)
- Frame Relay
- Ethernet/802.3
- 802.5 Token Ring
- X.25

It also supports packets across an 802.5 Source Routing Bridge (SRB).

The VINES protocol is implemented at the network layer (layer 3) of the OSI model. VINES routes packets from the transport layer in one node to the transport layer in another node. As VINES routes the packets to their destination nodes, the packets pass through the network layers of the intermediate nodes where they are checked for bit errors. A VINES IP packet can contain up to 1500 bytes including the network layer header and all higher layer protocol headers and data.

#### Service and Client Nodes

The VINES network consists of service nodes and client nodes. A service node provides address resolution and routing services to the client nodes. A client node is a physical neighbor on the VINES network. All routers are service nodes. A Banyan node can be a service node or client node.

Each service node has a 32-bit network address and a 16-bit subnetwork address. The IBM 2212 has a configurable network address. This address identifies the router as a service network node for Vines. Banyan has assigned the range 30800000 to 309FFFFFF to IBM for use in its routers. This router uses the range 30900000 to 3097FFFF.

## Using VINES

**Note:** It is extremely important that no two routers be assigned the same network address. The network address for a Banyan service node is the 32-bit hexadecimal serial number of the service node. The subnetwork address for all service nodes is 1.

The network address for each client node is generally the network address of the service node on the same network. However, if a client node is on a LAN that has more than one service node, it is assigned the network address of the service node that responds first to the client node's address assignment request. The subnetwork address for each client node is a hexadecimal value of 8000 to FFFE.

---

## VINES Network Layer Protocols

This implementation of VINES consists of the following four network layer protocols. The next sections describe these protocols and their implementations.

- "VINES Internet Protocol (VINES IP)". Routes packets through the network.
- "Routing Update Protocol (RTP)" on page 217. Distributes topological information to support the routing services provided by VINES IP.
- "Internet Control Protocol (ICP)" on page 220. Provides diagnostics and support functions to certain transport layer protocol entities, such as providing notification on some network errors and topological conditions.
- "VINES Address Resolution Protocol (VINES ARP)" on page 220. Assigns VINES internet addresses to client nodes that do not already have addresses.

## VINES Internet Protocol (VINES IP)

The VINES IP protocol routes packets through the network using the destination network number in the VINES IP header. VINES IP consists of an 18-byte network layer header which prefixes each packet. Table 50 on page 217 summarizes the fields within this header.

### VINES IP Implementation

When VINES IP receives a packet, it checks the packet for size and exception errors. A size error is a packet that is less than 18 bytes or greater than 1500 bytes. If it contains a size error, VINES IP discards the packet. An exception error is, for example, a bad checksum or a hop count that has expired.

If the packet does not contain size or exception errors, VINES IP checks the destination address and forwards the packet as follows:

- If the destination address equals the local VINES IP address and the checksum is valid, the local node accepts the packet.
- If the destination address equals the broadcast address and the checksum is valid, VINES IP accepts the packet, processes it locally, and checks the hop count field of the IP header. If the hop count is greater than 0, VINES IP decrements the hop count by one and rebroadcasts the packet on all local media except the one on which the packet was received.
- If the destination address does not equal the local VINES IP address or the broadcast address, VINES IP checks its routing tables for the next hop. If the hop count equals 0, VINES IP discards the packet. Otherwise, it decrements the hop count by one and forwards the packet to the next hop.

If the destination VINES IP address is not in the routing table and the error bit in the transport control field is set, VINES IP drops the packet and returns an ICP Destination Unreachable message to the source. If the error bit in the transport control field is not set, VINES IP discards the packet and does not return a message to the source.

Table 50. Vines IP Header Fields Summary

VINES IP Header Field	# of Bytes	Description
Checksum	2	Detects bit-error corruption of a packet.
Packet Length	2	Indicates the number of bytes in the packet including the VINES IP header and data.
Transport Control	1	<p>Consists of the following five subfields:</p> <p><b>Class</b> Determines the type of nodes to which VINES IP broadcast packets are sent.</p> <p><b>Error</b> If the error bit is set, an exception notification packet is sent to the transport layer protocol entity when a packet cannot be routed to a service or client node.</p> <p><b>Metric</b> Requests that the service node of the destination client node return to the source a routing cost from the service node to the destination client node.</p> <p><b>Redirect</b> Indicates whether the packet contains an RTP message specifying a better route to use.</p> <p><b>Hop Count</b> Specifies the range a packet can travel. The hop count can range from 0x0 to 0xf.</p>
Protocol Type	1	Specifies the VINES network layer protocol of the packet as VINES IP, RTP, ICP, or VINES ARP.
Destination Network Number	4	A 4-byte network number in the VINES IP address of the destination.
Destination Subnetwork Number	2	A 2-byte subnetwork number in the VINES IP address of the destination.
Source Network Number	4	A 4-byte network number in the VINES IP address of the source.
Source Subnetwork Number	2	A 2-byte subnetwork number in the VINES IP address of the source.

## Routing Update Protocol (RTP)

RTP gathers and distributes routing information that VINES IP uses to compute routes throughout the network. RTP enables each router to periodically broadcast routing tables to all of its neighbors. The router then determines the destination neighbor it will use to route the packet.

Service nodes maintain two tables: a routing table and a neighbor table. Both of these tables have timers that age their contents to eliminate out-of-date entries.

## Using VINES

Routing updates for X.25 interfaces occur when there is a change in the routing database, for example, when a node goes up/down or the metric changes.

### Routing Table

The routing table contains information about the service nodes. Figure 14 shows a sample routing table. Descriptions of the fields in this table follow the figure.

Net Address	Next Hop	Nbr Addr	Nbr Intf	Metric	Age (secs)
S 30622222		30622222:0001	Eth/0	20	30
H 0027AA21		0027AA21:0001	Eth/1	2	120
P 0034CC11		0034CC11:0001	X.25/0	45	0
3 Total Routes					

**S** ⇒ Entry is suspended, **H** ⇒ Entry is in Hold-down,  
**P** ⇒ Entry is permanent

Figure 14. Sample Routing Table

#### Routing Table Field Description

##### Net Address

The Net Address is a unique 32-bit number. An S, H, or P preceding the Net Address field indicates the following:

- S** Indicates the service node is in suspended state and is advertised, for 90 seconds, as being down. After 90 seconds, the router removes the entry for this service node from the routing table.
- H** Indicates the service node is in hold-down state and is advertised, for 2 minutes, as being down. After 2 minutes, the router advertises the service node as operational. If a service node is in suspended state and it receives an RTP packet, the service node enters the hold-down state.
- P** Indicates that the X.25 interface enters permanent state for 4-1/2 minutes after initialization. After 4-1/2 minutes, the neighbor enters the permanent state and its age stays at 0 while in this state. If the X.25 interface goes down, the entry is removed from the routing table.

##### Next Hop Nbr Addr

The address of the neighbor service node that is the next hop on the least-cost path to the network.

##### Nbr Intf

The medium to which the next hop neighbor service node is attached.

**Metric** An estimated cost, in 200-millisecond increments, to route the VINES packet to the destination service node.

##### Age (secs)

The current age, in seconds, for the entry. If a router does not receive an



update about a service node that is in the routing table at least every 360 seconds (6 minutes), the router removes the entry for that service node from the routing table.

## Neighbor Tables

The neighbor table contains information about the neighbor service nodes and client nodes connected to the router. Figure 15 shows a sample neighbor table and descriptions of the fields in this table follow the figure.

Nbr Address	Intf	Metric	Age(secs)	H/W Addr	RIF
30633333:0001	TKR/0	4	30	0000C0095012	
0035CC10:8000	Eth/1	2	120	0000C0078221	
2 Total Neighbors					

Figure 15. Sample Neighbor Table

### Neighbor Table Field Description

#### Nbr Address

The address of the neighbor node. In Figure 15, the address 30633333:0001 is a service node and address 0035CC10:8000 is a client node.

**Intf** The medium to which the neighbor node is attached.

**Metric** An estimated cost, in 200-millisecond increments, to route the VINES packet to the neighbor node.

#### Age (secs)

The current age, in seconds, for the entry. If a router does not receive a routing update from a neighbor at least every 360 seconds (6 minutes), the router removes the entry for that neighbor from the neighbor table and, if the neighbor is a service node, from the routing table.

#### H/W Addr

The node's LAN address if the neighbor is connected to a LAN. If the frame relay protocol is running, the H/W Addr is the Data Link Connection Identifier (DLCI). For X.25 interfaces, the H/W Addr is the X.25 address of the neighbor.

**RIF** Routing Information Field. A sequence of segment and bridge numbers, in hexadecimal, which indicate a path through the network between two stations. RIF is required for source routing.

## RTP Implementation

RTP entities issue the following packets:

- *RTP request packets.* Requests to the service nodes to obtain the current network topology. On initialization, an X.25 interface generates routing request packets every 90 seconds to each X.25 destination on the X.25 interface. When the X.25 interface receives a routing response packet, three full routing database updates, spaced 90 seconds apart, are sent to the services nodes that sent the

## Using VINES

routing response packets. Once the X.25 interface receives routing response packets from all of the X.25 destination nodes, routing requests are no longer sent to those X.25 addresses.

- *RTP update packets.* Packets sent by client nodes to the service nodes to notify the service nodes of their existence. RTP update packets are also sent by the service nodes to notify other nodes of their existence and to advertise their routing databases.
- *RTP response packets.* Packets service nodes send in response to RTP request packets.
- *RTP redirect packets.* Informs the nodes of the best paths between them for routing packets.

Unless connected by a permanent circuit, every client and service node broadcasts an RTP update every 90 seconds. This notifies the neighbors of the node's existence and its type (service or client node) and, in the case of service nodes, advertises their routing databases. When a router receives an update packet from a service node, RTP extracts the VINES IP address and looks in the routing table for an existing entry on that service node. If it exists, RTP updates the entry and resets the entry's timer. If an entry does not exist, RTP creates one and initializes the timer for that entry.

## Internet Control Protocol (ICP)

ICP generates network information messages on two types of packets destined for the local router:

- *Destination unreachable packet.* Indicates a packet could not reach its destination and was returned to its source. The router then issues an ELS message and flushes the packet.
- *Delay metric packet.* A request packet from a source node for the routing metric from the destination service node to the destination client node.

## VINES Address Resolution Protocol (VINES ARP)

The VINES ARP protocol assigns unique VINES IP addresses to the client nodes. VINES ARP includes the following packet types:

- *Query request packet.* Packets the client nodes broadcast on initialization.
- *Query response packet.* The service node's response to a query request packet.
- *Assignment request packet.* The client node's response to a query response packet.
- *Assignment response packet.* Includes the network and subnet addresses the service node assigned to a client node.

To assign a VINES IP address to a client node, VINES ARP implements the following algorithm:

1. The client node broadcasts a query request packet.
2. Service nodes respond with a query response packet containing the destination MAC address of the client node and a broadcast VINES IP address.
3. The client node issues an assignment request packet to a service node that responded with a query response packet.
4. The service node responds with an assignment response packet that contains the VINES network and subnetwork addresses.

Each client node maintains a timer that has a default setting of two seconds. The timer starts when a client node transmits a query request or assignment request packet. The client node stops and resets the timer when it receives a query response packet. When a timeout period exceeds two seconds, the client node initializes, broadcasts a query request packet, and resets the timer. Table 51 summarizes the states the service and client nodes enter during VINES ARP implementation.

Table 51. Client and Service Node VINES ARP States

Client Node States	
Initialization	The client node is initializing.
Query	The client node is transmitting a query request packet.
Request	The client node received a query response packet from a service node and is transmitting an assignment request packet to the service node it heard from.
Assigned	The client node received an assignment response packet containing the VINES network and subnetwork addresses.
Service Node States	
Initialization	The VINES ARP protocol is initializing.
Listen	The service node is waiting for query request packets from the client nodes.
Service	The service node received a query request packet and sent a query response packet.
Assignment	The service node issues an assignment response packet containing the VINES network and subnetwork addresses.

## Basic Configuration Procedures

The steps to initially configure each router that sends and receives VINES packets are as follow:

1. Assign a unique 32-bit hexadecimal address to each router in the VINES network. Using the **set network-address** *hex #* command, enter a network address from 30900000 to 3097FFFF. The network address for Banyan servers is the 32-bit hexadecimal serial number of the service node. This number is automatically read from the node server key.
2. Globally enable the VINES protocol using the **enable VINES** command.
3. Enable the interface cards that are to transmit and receive the VINES packets using the **enable interface** *interface#* command.

For configuration changes to take effect you must restart the router. Enter **reload** after the OPCON prompt (\*) and answer **yes** to the following prompt:

Are you sure you want to **reLoad** the router? (Yes or No): **yes**

To view the configuration, enter the **list** command after the VINES config> prompt.

## Running Banyan VINES on the Bridging Router

Banyan VINES servers must have this Banyan option to communicate with other servers or routers:

Server-to-server LAN.

## Using VINES

To communicate across X.25 WANs, VINES servers directly connected to the WAN need these two options:

- Server-to-server WAN

- X.25 support on the server (hardware and software).

## Running Banyan VINES over WAN Links

When you set up a PPP, Frame Relay, or X.25 link for use with VINES, you must set the HDLC speed of the link, even if you set the clocking to external.

If you set the HDLC speed to zero, VINES assumes that the speed is 56 Kbps. Do not set the speed to a value that is faster than the line.

---

## Chapter 6. Configuring and Monitoring VINES

This chapter describes the VINES configuring and monitoring commands and includes the following sections:

- “Accessing the VINES Monitoring Environment” on page 227
- “VINES Monitoring Commands” on page 227

---

### Accessing the VINES Configuration Environment

To access the VINES configuration environment, enter the following command at the Config> prompt:

```
Config> protocol vin
VINES Protocol user configuration
VINES Config>
```

---

### VINES Configuration Commands

This section summarizes and then explains the VINES configuration commands. Enter these commands at the VINES config> prompt.

*Table 52. VINES Configuration Commands Summary*

Command	Function
? (Help)	Displays all the commands available for this command level or lists the options for specific commands (if available). See “Getting Help” on page xxvi.
Add	Adds an X.25 address translation.
Delete	Deletes an X.25 address translation.
Disable	Disables the VINES protocol on all interfaces or a single interface and disables checksumming.
Enable	Enables the VINES protocol on all interfaces or a single interface and enables checksumming.
List	Displays the current VINES configuration.
Set	Assigns the network addresses to routers in the VINES network and sets the maximum number of physical neighbor client and service nodes.
Exit	Returns you to the previous command level. See “Exiting a Lower Level Environment” on page xxvi.

#### Add

Adds an X.25 address translation.

##### Syntax:

```
add                _interface ...
```

**#** Specifies the interface number.

##### **remote-X.25-addr**

Can include up to 15 digits. If the virtual circuit connection has been configured as PVC, the VINES *remote-X.25-addr* must match the PVC address configured at the X.25 prompt. If the addresses do not match, the system defaults to a switched virtual circuit (SVC).



## VINES Configuration Commands (Talk 6)

vines

### **checksumming** *interface#*

Enables checksumming on packets that the specified interface generates.

**Example: enable checksumming 0**

### **interface** *interface#*

Enables the VINES protocol on the specified interface.

**Example: enable interface 1**

**vines** Globally enables the VINES protocol. If you receive an error message after entering this command, contact your customer service representative. The VINES software may not be in your software load.

**Example: enable vines**

## List

Use the **list** command to display the current VINES configuration.

### **Syntax:**

**list**

### **Example: list**

```
VINES: enabled/disabled
VINES network number (hex):
Maximum Number of Routing Table Entries:
Maximum Number of Neighbor Service Nodes:
Maximum Number of Neighbor Client Nodes:

List of interfaces configured for VINES:

intf 0      (checksumming enabled/disabled)
intf 1      (checksumming enabled/disabled)
intf 2      (checksumming enabled/disabled)

VINES X.25 Configuration

Interface   Remote X.25 Address   Remote Handle
0           4508907898           test

VINES config>
```

**VINES** Indicates whether VINES is globally enabled or disabled.

### **VINES network number (hex)**

A configurable 32-bit hexadecimal address for routers in the VINES network.

### **Maximum Number of Routing Table entries**

A configured value specifying the maximum number of entries allowed in the VINES routing table.

### **Maximum Number of Neighbor Service Nodes**

A configured value specifying the maximum number of neighbor service nodes connected to the router.

### **Maximum Number of Neighbor Client Nodes**

A configured value specifying the maximum number of client nodes connected to the router.

### **List of interfaces configured for VINES**

Displays the interfaces that have VINES enabled and whether checksumming is enabled or disabled.

## VINES Configuration Commands (Talk 6)

### VINES X.25 Configuration

This information represents the following:

#### Interface

The interface that is configured for X.25.

#### Remote X.25 Address

The DTE address of the remote server.

#### Remote Handle

A user-configurable name that uniquely identifies the remote server.

## Set

Use the **set** command to assign network addresses to routers in the VINES network and to specify the maximum number of client and service nodes.

### Syntax:

```
set                client-node-neighbors ...  
                   network-address ...  
                   routing-table-size ...  
                   service-node-neighbors ...
```

### **client-node-neighbors #**

Specifies the maximum number of client nodes on your network.

**Client-node-neighbors** includes all of the nodes on each network directly connected through the router. The range is 1 to 65535, and the default is 25.

**Note:** It is recommended that you set this number significantly higher than the number of nodes in your network. This will enable your network to continue functioning without reconfiguring and restarting the routers when additional nodes are added. The increase in this number depends on the size of your network and the amount of anticipated growth. As a rule, set **client-node-neighbors** 25 % higher than the actual number of client stations on LANs that are local to the router.

**Example: set client-node-neighbors 20**

### **network-address hex#**

Assigns a network address to each router in the VINES network. *Hex#* is a 32-bit hexadecimal value from 30900000 to 3097FFFF.

**Example: set network-address 30922222**

### **routing-table-size #**

Specifies the maximum number of service nodes and routers in the VINES network. The range is 1 to 65535, and the default is 300.

**Note:** Make sure that the number you specify is large enough to accommodate additional VINES servers and 2212s as your network grows.

**Example: set routing-table-size 250**

### **service-node-neighbors #**

Specifies the maximum number of physical neighbor service nodes. This



## VINES Configuration Commands (Talk 6)

number includes VINES servers and 2212s that are the first point-of-contact after crossing a WAN. The range is 1 to 65535, and the default is 50.

**Example:** `set service-node-neighbors 100`

---

## Accessing the VINES Monitoring Environment

To access the VINES monitoring environment,

```
* t 5
```

Then, enter the following command at the `+` prompt:

```
+ protocol vin
VINES>
```

---

## VINES Monitoring Commands

This section describes the VINES monitoring commands. Enter these commands at the VINES> prompt.

*Table 53. VINES Monitoring Command Summary*

Command	Function
? (Help)	Displays all the commands available for this command level or lists the options for specific commands (if available). See "Getting Help" on page xxvi.
Counters	Displays routing errors and the number of times the VINES input queue was full when packets were received from the specified interface.
Dump	Displays the current contents of the VINES routing and neighbor tables.
Route	Displays an entry from the VINES routing table.
Exit	Returns you to the previous command level. See "Exiting a Lower Level Environment" on page xxvi.

## Counters

Use the **counters** command to display routing errors and the number of times the VINES input queue was full when packets were received from the specified interface.

### Syntax:

**counters**

### Example: counters

```
Routing Errors
Count      Type
-----
 2         Net Unreachable
 3         Hop Count Expired
 3         Routing Update from Orphan Client
 0         Routing Redirect Received
 0         Routing Response Received

VINES Input Packet Overflows
Net        Count
----
Eth/0     5
Eth/1     1
```

## VINES Monitoring Commands (Talk 5)

### Net Unreachable

The number of times the router received a packet destined for a node that was not found in the routing table.

### Hop Count Expired

The number of times the router discarded a packet because its hop count expired.

### Routing Update from Orphan Client

The number of times the router received an update packet from a client node whose service node does not exist. A routing update from an orphan client can occur when the router boots and hears from the client node first rather than the service node, or when a client's service node is down and an entry has been removed from the routing table database.

### Routing Redirect Received

The number of times the router received redirect packets from the service nodes.

### Routing Response Received

The number of times response packets were generated as a result of request packets initiated by the router.

### VINES input packet overflows

The number of times the VINES forwarder input queue was full when packets were received from the specified interface. The packets are subsequently discarded.

## Dump

Use the **dump** command to display the contents of the VINES routing and neighbor tables.

### Syntax:

```
dump                neighbor-tables  
                    routing-tables
```

### neighbor-tables

Displays information about each neighbor service and client node connected to the router.

### Example: dump neighbor-tables

Nbr Address	Intf	Metric	Age(secs)	H/W Addr	RIF
30622222:0001	TKR/0	4	30	0000C00	95012
0035CC10:8000	Eth/0	2	120	0000C00	78221

2 Total Neighbors

### Nbr Address

The address of the neighbor node. In the above example, address 30622222:0001 is a service node and address 0035CC10:8000 is a client node.

**Intf** The medium to which the neighbor node is attached.

**Metric** An estimated cost, in 200-milliseconds, to route the VINES packet to the neighbor node.

### Age (secs)

The current age, in seconds, for the entry. If a router does not receive a routing update from a neighbor at least every 360

## VINES Monitoring Commands (Talk 5)

seconds (6 minutes), the router removes the entry for that neighbor from the neighbor table and, if the neighbor is a service node, from the routing table.

### H/W Addr

The node's LAN address if the neighbor is connected to a LAN. If the frame relay protocol is running, the H/W Addr is the Data Link Connection Identifier (DLCI). For X.25 interfaces, the H/W Addr is the X.25 address of the neighbor.

### RIF

Routing Information Field. A sequence of segment and bridge numbers, in hexadecimal, which indicate a path through the network between two stations. RIF is required for source routing.

## routing-tables

Displays information about each service node known by the router.

### Example: dump routing-table

Net Address	Next Hop Nbr Addr	Nbr Intf	Metric	Age (secs)
S 30622222	30622222:0001	Eth/0	20	30
H 0027AA21	0027AA21:0001	Eth/1	2	120
P 0034CC11	0034CC11:0001	X.25/0	45	0

3 Total Routes

S ==> Entry is suspended, H ==> Entry is Holddown, P ==> Entry is permanent

### Net Address

The Net Address is a unique, configurable 32-bit hexadecimal value from 30900000 to 3097FFFF. This range of numbers is assigned to IBM by Banyan. It is very important that no two routers on a network are assigned the same Net Address. The Net Address for a Banyan service node is the 32-bit hexadecimal serial number of the service node. An S, H, or P preceding the Net Address field indicates the following:

- S:** The service node is in suspended state and is advertised, for 90 seconds, as being down. After 90 seconds, the router removes the entry for this service node from the routing table.
- H:** The service node is in hold-down state and is advertised, for 2 minutes, as being down. After 2 minutes, the router advertises the service node as operational. If a service node is in suspended state and it receives an RTP packet, the service node enters the hold-down state.
- P:** After initialization, the X.25 interface enters permanent state for 4 and 1/2 minutes. After 4 and 1/2 minutes, the neighbor enters the permanent state and its age stays at 0 while in this state. If the X.25 interface goes down, the entry is removed from the routing table.

### Next Hop Nbr Addr

The address of the neighbor service node that is the next hop on the least-cost path to the network.

### Nbr Intf

The medium to which the next hop neighbor service node is attached.

### Metric

An estimated cost, in 200-milliseconds, to route the VINES packet to the destination service node.

## VINES Monitoring Commands (Talk 5)

### Age (secs)

The current age, in seconds, for the entry. If a router does not receive a routing update about a service node that is in the routing table at least every 360 seconds (6 minutes), the router removes the entry for that service node from the routing table.

## Route

Use the **route** command to view an entry from the routing table.

### Syntax:

**route** given address

### given address

The network address of the service node.

### Example: route 30622222

Net Address	Next Hop Nbr Addr	Nbr Intf	Metric	Age (secs)
30622222	30622222:0001	Eth/0	2	30

---

## Chapter 7. Using DNA IV

This chapter describes IBM's implementation of Digital Network Architecture Phase IV (DNA IV) and includes the following sections:

- "DNA IV Overview"
- "IBM's Implementation of DNA IV" on page 234
- "Configuring DNA IV" on page 243
- "DNA IV Configuration and Monitoring Commands" on page 247

---

### DNA IV Overview

DNA IV is a collection of software components that transfer information between networks connected by physical media. By transferring information, DNA IV software facilitates communication between network devices, such as personal computers, file servers, and printers.

DNA IV protocol is the underlying protocol for Digital Equipment Corporation's DECnet software products as well as DNA-compatible products. DNA IV protocol includes the following:

- Routing software for DNA IV protocol networks.
- NCP, an implementation of the DNA IV Network Control Program. For more information, refer to the appropriate DECnet-VAX documentation, published by Digital Equipment Corporation.
- Support for DNA IV Maintenance Operations Protocol (MOP).

DNA IV performs two major functions:

- Maintains a complete routing database on all nodes in its area. (If the router is operating as a level 2 router, it maintains the database for all areas as well.)
- Routes incoming DECnet data packets to the appropriate destinations based on its own routing database. It ignores packets that are addressed to the router that are not hello packets or routing packets.

DNA IV supports the following:

- Multiple areas on an Ethernet or Token-ring network.
- Basic MOP operations. DNA IV responds to a MOP Request ID message with a MOP System ID message. DNA IV also sends a MOP system ID Message when a circuit comes up. You can monitor MOP messages using the Ethernet configuration module under DECnet-VAX NCP. The router NCP does not include an Ethernet configuration module.
- LAT Protocol. LAT protocol is not part of the DNA IV protocol family. It is an Ethernet-only protocol intended only for short-distance (limited round-trip time) communications. (CTERM protocol provides wide-area terminal support using DNA IV protocols across routers. The **set host** command in DECnet-VAX provides the CTERM protocol.)

Special consideration should be given to the following DNA IV restrictions:

- DNA IV does not support the NSP, Session, or NICE protocols.
- DNA IV does not support the DDCMP line protocol on its directly connected synchronous lines.

## Using DNA IV

- DNA IV does not provide any Phase III compatibility features because it does not support the DDCMP data link protocols used by all Phase III nodes.
- NCP (the router's implementation of the DECnet Network Control Program) implements a subset of the original NCP commands and functions.

## DNA IV Terminology and Concepts

This section contains a brief description of DNA IV terminology.

### Addressing

Each node has a 16-bit node address, which is the same for all interfaces on that node. An address consists of 2 fields: 6 bits of area number and 10 bits of node number. Addresses are printed in decimal with a period separating the area and the node, such as 1.7 is node 7 in area 1. If no area is given, area 1 is assumed. Any address in the range 1.1 to 63.1023 is legal. Both nodes and areas should be numbered starting from 1, with few, if any, gaps. This is because the maximum node number and the maximum area numbers are configuration options and control the size of many of the routing data structures.

There is no direct correlation between addresses and physical cabling. Routes are computed to nodes, not wires.

### Ethernet Data Link Addressing

Each Ethernet interface is set to the same 48-bit physical address, which is the concatenation of a 32-bit prefix (AA-00-04-00) and the 16-bit DNA IV node address. The node address is byte-swapped (to convert from PDP11 to Ethernet byte order). Thus, DNA IV node 1.1 has Ethernet Address AA-00-04-00-01-04.

Multicast (not broadcast) is also used in routing. The three multicast addresses used by DNA IV are AB-00-00-02-00-00, AB-00-00-03-00-00, and AB-00-00-04-00-00.

### 802.5 Token-Ring Data Link Addressing

The implementation of DNA over IEEE 802.5 Token Ring conforms to the *DECnet Digital Networking Architecture (Phase IV) Token-Ring Data Link and Node Product Functional Specification*, Version 1.0.0, that includes support for Arbitrary MAC Addresses (AMA).

There are two types of MAC addressing, conventional DNA IV addressing, which is the concatenation of a 32-bit prefix (AA-00-04-00) and the 16-bit DNA IV area/node address or AMA that allows the DNA protocol to run on IEEE 802.5 nodes without their MAC addresses being changed by the DNA protocol. This is necessary if you follow certain IBM protocol conventions. You can select the type of addressing that you are using through the DNA configuration process (NCP>).

Another type of addressing representation is native bit-order. This type of address is byte-flopped when sent over the physical layer. For example, the canonical 32-bit prefix shown above (using dashes) is expressed as 55:00:20:00 in native bit-order with colons separating each byte.

## X.25 Data Link Addressing

The router supports DECnet Phase IV over X.25 and can interoperate with routers running Digital's implementation of DECnet Phase IV over X.25.

You set up the local and the remote DTE address with the **set/define circuit** command when you set up a DECnet circuit. In the *call-userdata* parameter you specify the local DTE address in hexadecimal octets (characters). In the *DTE-address* parameter you specify the remote address in hexadecimal octets. Both the local and remote DTE addresses can be up to 14 hexadecimal octets in length with two ASCII characters representing one hexadecimal octet.

## Routing

DNA IV handles both forwarding of DNA IV data packets and automatic routing with other DNA IV nodes. The router performs the following DNA IV functions:

- Announces its presence by sending hello messages on each network that has DNA IV enabled.
- Maintains a list of adjacent DNA IV nodes from the hello packets it receives from other DNA IV nodes.
- Exchanges routing information with other routers.
- Forwards packets between nodes.

All end and routing nodes periodically broadcast hello messages to the all-routers multicast address. This allows each router to locate other nodes in its area.

On each broadcast network (for example, Ethernet, Token-Ring), one router declares itself the designated router for that wire. The designated router broadcasts its presence so that the end-nodes know to use it as their default gateway. Any end-node sending a packet to a node not on that wire automatically sends it to the designated router for forwarding.

In a multi-area DNA, assign priorities to routers in such a way that the designated router is a level 2 router, or is likely to be the best next hop to commonly-used destinations. This reduces the possibility of traffic from end-nodes having to take an extra hop.

Routing decisions are based on a least-cost algorithm. Each link (e.g., point-to-point, broadcast network, hop) has a cost. Every router broadcasts (to other routers only) its cost and the number of hops to get to every node in its area. In this way, each router finds the cheapest path, subject to a maximum hop count.

## Routing Tables

A router forwards any DNA IV data packet it receives to the proper node based on its routing table. To maintain its routing table, a router listens to and sends level 1 updates to every node in its area. If the router's type is set to AREA, it also exchanges level 2 routing updates.

Each router maintains a routing table with an entry for every node (up to the maximum address) and every possible next hop (all circuits and up to the maximum broadcast routers). Each entry in this table contains the cost and hop to reach a node via one circuit or next hop node. Once a second the routing table sends out a broadcast routing timer.

## Using DNA IV

### Area Routers

If the router is configured as an area router, it maintains a similar database for all of the areas up to the maximum area, and can exchange area routing information with other area routers. Areas are handled almost exactly the same as nodes, except messages give costs to areas, but not nodes.

The areas concept results in two types of routing nodes:

- A level 1 router only knows about one area, so it keeps track of nodes in its area. Also, it ignores adjacencies across areas.
- A level 2 router keeps an area routing database, and can have cross-area adjacencies. Level 2 routers advertise routes to all other areas, so level 1 routers send all foreign-area traffic to the level 2 routers.

End-nodes simply pass packets on to a router.

A level 2 router that can reach other areas advertises a route to node 0 within its area. When level 1 routers need to send a packet to another area, they route it toward the closest node 0. This is not necessarily the best route to that area. From there, the level 2 routing algorithm sends the packet to its destination area.

## Configuring Routing Parameters

In each system you can set the following routing parameters:

- Maximum number of nodes in the area
- Maximum number of routers adjacent to this router
- Maximum number of networks on any given node
- Maximum number of end-nodes one hop away from this end-node
- Cost of a hop on each network to which this node is attached
- Values of several timers involved in sending hello messages and expecting them from other nodes

---

## IBM's Implementation of DNA IV

The main user interface program for the router's implementation of DNA IV is called NCP. The router's NCP is a limited subset of the DECnet Network Control Program (NCP) commands. The router's NCP enables you to view and modify the various operating arguments of DNA IV and to read various DNA-specific counters.

Some of the features of the router's NCP include the following:

- NCP implements new entities: module access-control and module routing-filter.
- NCP has no **set executor buffer size** command because the router does not originate any DECnet traffic. The router can forward the largest packet any DECnet implementer can generate. It honors the buffer size restrictions of all adjacent nodes.
- NCP allows an **all** qualifier on the **node**, **area**, and **circuit** subcommands.

The router NCP is similar to NCP on DECnet-VAX, with the following differences:

- Router NCP does not include the **set node name command**, and therefore cannot assign names to nodes, or display node names with addresses.



- Router NCP does not include the **clear** or **purge** commands, nor do the **set** commands have an **all** argument. The permanent database is always copied to the volatile database when the router starts, restarts, or boots.
- A router NCP command can have only one argument.
- NCP does not have the concept of lines. To see the data that a DECnet-VAX NCP **show line** command displays, use the GWCON **interface** and **network** commands.
- Router NCP does not support cross-network commands:
  - Router NCP does not include the **tell** command, which requests NCP commands on other nodes.
  - Similarly, router NCP does not support protocol requests from other DNA routers to execute NCP commands at the router on their behalf.

### Important

Before configuring DNA IV, you need to be aware of the optional security features discussed in:

- “Managing Traffic Using Access Control”
  - Provides additional security by limiting access within routers in the network.
- “Managing Traffic Using Area Routing Filters” on page 238
  - Limits access to group of areas from other areas
  - Allows blending of two DECnet address spaces

If you already are familiar with these topics, skip these two sections and begin reading at “Configuring DNA IV” on page 243.

## Managing Traffic Using Access Control

Access control protects one group of nodes from other nodes on the network. Routers make all nodes on a network accessible to each other. Usually, the main forms of security are passwords and conservative use of DNA IV proxy access at the host level.

However, due to differences in the security level of machines, you might need to provide additional security by limiting access within the routers in the network. The DNA forwarder enables you to do this using access controls.

Generally, access controls are not recommended due to the following liabilities:

- Access controls affect performance of the router because every packet is tested. The more complicated the access control configuration, the greater the performance impact.
- Access controls are difficult to configure and errors in configuration are difficult to diagnose.
- Access controls cannot hide a node from the routing protocols. The node remains visible from all routers in its area.

**Note:** Access controls do not guarantee security; they only make intrusion more difficult. The DNA IV routing protocols used on Ethernet and other broadcast media do not have built-in security features.

## Using DNA IV

Access control prevents the forwarding of DNA IV (Long Format) data packets on the basis of source address, destination address, and interface. Access control does not affect routing packets, because they use a different packet format. This makes configuring access control safer, because you cannot break the routing protocol.

To implement access control, addresses are masked and compared. That is, the address in question is masked with 1s in the bit positions to be tested, and 0s in the free area. The address is then compared to a fixed value. For example, you could use a mask of 63.1023 (all 1s), and compare it to a result of 6.23 which would be true only for node 6.23. You could use a mask of 63.0 and a result of 9.0 which would be true for any node in area 9.

These mask and compare values come in pairs for source and destination address. They are then formed into lists for an interface. Each interface can have one access control list, which is applied to packets received on that interface. This list may be inclusive or exclusive. An inclusive list is a set of address pairs that designates a corridor for traffic flow. An exclusive list is a set of address pairs that does not allow traffic flow.

In an inclusive list, the source and destination addresses are tested using the mask and compare values. If any entry's source and destination matches, the packet is forwarded. In an exclusive list, the source and destination addresses are tested using the mask and compare values. If any entry's source and destination matches, the packet is dropped. The choice between exclusive and inclusive should be made on the basis of which list will be shorter. However, exclusive access control is usually easier to configure.

When packets are dropped due to access controls, the Return to Sender Request (RQR) bit is set in the Long Format Data Packet header and the packet is returned. Then, the connect request immediately fails, because NSP Connect Initiate packets are normally sent with the RQR bit set.

### Configuring Access Control

Access control limits access to a particular host or group of hosts. You must assign access control to all routes to that host, not just the preferred route. Otherwise, access control functions when the primary route is up, but fails when the secondary route is in use.

On your network map, draw a line to isolate the secure region from the rest of the network. Ideally the line should cross the minimum possible set of adjacencies so that the least number of interfaces are running with access control. For broadcast networks (Ethernet and Token-Ring), draw the line through the drop cable to the node, to identify the interface to filter. For each interface crossed by the access control line, use NCP to define the same access control list.

**Note:** Because all DECnet applications use the NSP protocol, which requires bidirectional connectivity, you do not need to define access controls in both directions.

### Inclusive Access Control

In Figure 16 on page 237, node 1.13 wants to communicate with nodes 1.2 and 1.4 only. Access control allows you to secure nodes from all nodes connected by routers. Therefore, in Figure 16 on page 237 you can protect node 1.13 from all

nodes except node 1.9 because these two nodes share the same physical network. To configure the desired access control for this example, build an inclusive filter on interface Eth/0 of router 1.19 as shown in the bottom of Figure 16

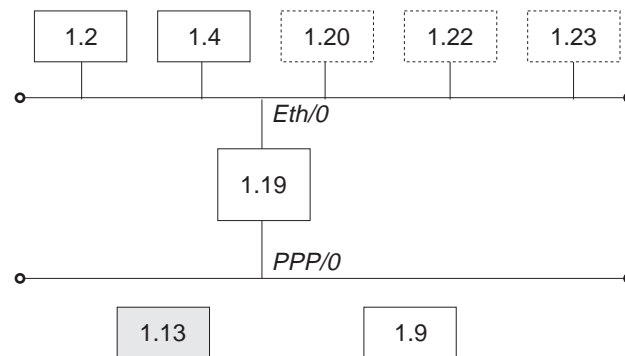

#### Inclusive Filter Information

Source Result	Source Mask	Destination Result	Destination Mask
1.2	63.1023	1.13	63.1023
1.4	63.1023	1.13	63.1023
0.0	0.0	1.9	63.1023

Figure 16. Example of Inclusive Access Control

The first and second entries of the inclusive filter information shown in Figure 16 allow nodes 1.2 and 1.4 to send packets to node 1.13. The third entry allows any node to send to node 1.9 (you are not trying to secure node 1.9).

To configure the example given for router 1.19, enter the following NCP commands and parameters:

```
NCP> def mod access-cont circ eth/0 type inclusive
NCP> def mod access-cont circ eth/0 filter 1.2 63.1023 1.13 63.1023
NCP> def mod access-cont circ eth/0 filter 1.4 63.1023 1.13 63.1023
NCP> def mod access-cont circ eth/0 filter 0.0 0.0 1.9 63.1023
NCP> def mod access-cont circ eth/0 state on
```

## Exclusive Access Control

Figure 17 on page 238 shows how exclusive access control isolates node 4.4 from the rest of the campus.

## Using DNA IV

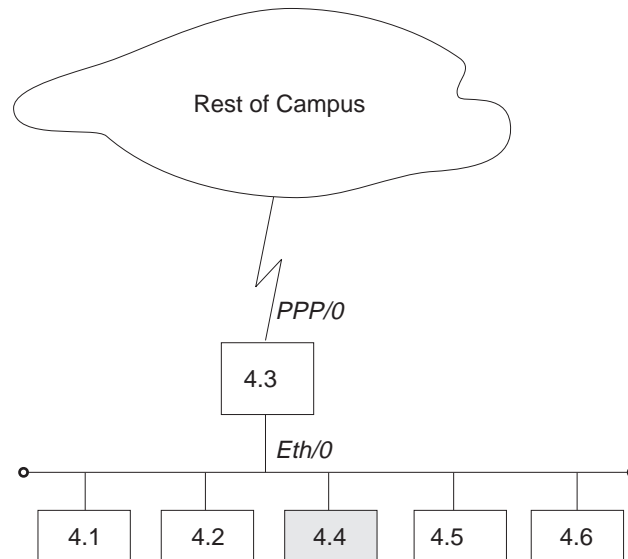

### Exclusive Filter Information

Source Result	Source Mask	Destination Result	Destination Mask
0.0	0.0	4.4	63.1023

Figure 17. Example of Exclusive Access Control

Configure the desired access control for this example by building an exclusive filter on the PPP/0 interface of router 4.3 as shown in Figure 17. To configure the example given for router 4.3 in Figure 17, enter the following NCP commands and parameters:

```
NCP> def mod access-cont circ ppp/0 type exclusive
NCP> def mod access-cont circ ppp/0 filter 0.0 0.0 4.4 63.1023
NCP> def mod access-cont circ ppp/0 state on
```

## Managing Traffic Using Area Routing Filters

Area routing filters allow special configurations of your DNA network. Because this is an advanced topic, very few DNA IV networks need routing filters. There are two primary applications for area filtering in DNA IV:

- Security, limiting access to some group of areas from other areas.
- Allowing the blending of two DECnet address spaces.

**Note:** Area Routing Filters are very tricky and subtle to configure. It is very easy to completely break your area routing. If you do not understand how DECnet routing works, especially at the area level, do not try to use routing filters. Documentation on the DECnet routing protocol can be found in *DECnet Digital Network Architecture Phase-IV Routing Layer Functional Description*, Order Number AAX435ATK, December 1983, Digital Equipment Corporation, Maynard, Massachusetts.

Area routing filters allow you to configure a router to control the information about DECnet areas that are sent or accepted in level 2 routing messages. You may configure separate incoming and outgoing filters for each interface. Each filter specifies which areas routing information will be passed to or accepted from.

When a network sends a level 2 routing update and there is a routing filter, the entry (RTGINFO) for any area not in the filter has the cost of 1023 and a hop count of 63. Any area in the filter has the correct cost and hops placed in the entry.

When the network receives a level 2 routing message and there is a routing filter, any entry for an area not in the filter is treated as if the cost is 1023 and the hop count is 63 (unreachable). Any routing entry from the packet that is in the filter is processed normally.

The routing filters affect the processing of level 2 routing messages only. There are no filters for level 1 routing messages. Routing filters have no effect on router hello processing, and do not prevent area routers from developing adjacencies. They affect the area routing database. If the filters prevent an area router from learning about another area, they would prevent the router from becoming attached, and then the router could not advertise as an area router.

### Security by Area Filtering

Like access controls, routing filters provide security. However, routing filters have some disadvantages compared to access controls:

- Area filtering is less flexible than access controls because it requires the assignment of areas to correspond to the desired security architecture.
- Area filtering is more difficult to understand and configure.
- The level of security is lower because a host that ignores the lack of routing information can send the packets to the correct router anyway.

However, area filtering is more efficient because there is no need to check every packet. In the following example area filtering occurs in an area that contains workstations that are part of a large network that contains machines with confidential information. There might be one machine outside the area that the confidential machines need to reach for information.

In Figure 18 on page 240, area 13 contains workstations that need to be able to reach area 7. Node 13.1 is the router, and the other nodes are the workstations. Node 13.1 has a filter to accept only routes to area 7. Therefore, if node 13.1 receives a packet from any node in area 13 not destined for area 7, node 13.1 cannot forward the packet and sends the sending node an error message.

To configure router 13.1 in Figure 18 on page 240, enter the following NCP commands and parameters:

```
NCP> def mod routing-filter circ eth/1 incoming area 7
NCP> def mod routing-filter circ eth/1 incoming state on
```

## Using DNA IV

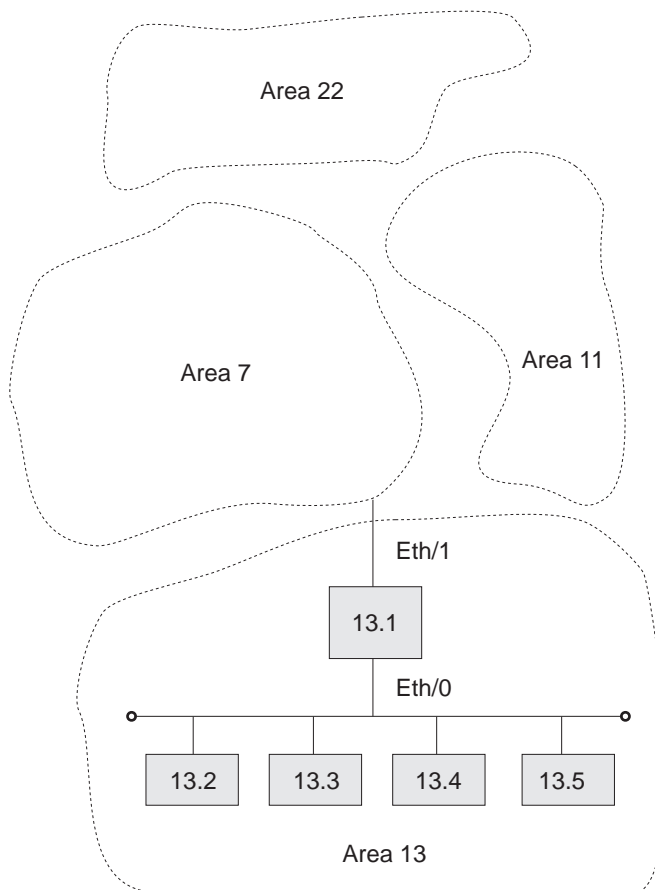

Figure 18. Example of Area Routing Filter for Security

### Blending DECnet Domains

DECnet has a 16-bit node address space with a fixed hierarchy of 6 bits of area and 10 bits of node. By comparison, IP has a 32-bit node address space with a flexible multilevel hierarchy. Many established networks have now grown to the point where they use all 63 areas. The problem is that as different facilities connect to each other, they want to connect their DECnet networks but cannot due to area number conflicts.

The only solution is to redesign the DECnet architecture. (This is addressed by DECnet Phase V.) However, by using area routing filters, it is possible to allow some overlap between two DECnet domains.

Domain is not a standard DECnet term; it is used here as a name for a DECnet wide-area network, presumably one with many areas. The goal is to blend two of these domains, so that there is a common area that can reach parts of both domains. However, there are more than 63 areas in the union of the two domains. Because area filtering is not simple to administer and is restrictive, you should not consider using it if there are enough area numbers available for the union of the domains.

To configure the overlap of two domains, first you must decide which areas to intersect. These areas are the ones that will be able to participate in both domains. These area numbers must not be used elsewhere in the two domains.

Figure 19 on page 242 shows the areas that intersect are areas 1 and 2. The remainder of the areas can be duplicated between the two domains. In the example, there are two areas 3, 4, and 5, one in each domain. Note that it is never possible to allow direct connection between a node in area 3 in domain A and area 3 in domain B. The best that you can do is give the areas in the intersection the ability to talk to portions of each domain.

In designing the intersection, be careful that neither domain relies on routes through the intersection to maintain connectivity between areas that are not in the intersection. Because the routes in and out of the intersection are filtered, they probably do not offer normal reachability between all areas in the domain.

To decide how to configure the routing filters, draw a concise map of the configuration. On this map, locate all of the areas and outline the two domains. Then decide upon the filtering fence that you need to establish. Carefully go around the intersection of the two domains and locate all level 2 adjacencies that cross the filtering fence. These are one hop communications paths between level 2 routers that cross between areas.

In the example, there are six adjacencies that cross the fence, 1.18 to 5.7, 1.18 to 5.8, 1.18 to 8.3, 2.17 to 3.12, 2.21 to 4.7, and 2.21 to 4.9.

The first step in designing the area filters is to set up filters that keep the areas in one domain from being propagated into the other domain. The only area routes that should leave the intersection are those for areas in the intersection. In the example, these are areas 1 and 2. Therefore, only routes for areas 1 and 2 should be sent from nodes such as 2.17 and 3.12.

On point-to-point links such as 2.17 and 3.12, it does not matter which end filters, but it is probably safer to filter on the sending end. Therefore there would be a filter on the interface of 2.17, allowing forwarding only routes from areas 1 and 2. The same would occur on the two interfaces of 2.21 and the link from 1.18 and 8.3.

When the hop between two areas is an Ethernet or other broadcast media, such as 1.18 to 5.7 and 5.8, you should make the decision on another basis. Most Ethernets have most of the level 2 routing nodes in one area, and a few in the second area. Here, the filtering should be on the few, rather than the many. In the example, node 1.18 is the interloper on the Ethernet in area 5, so it should filter. Node 1.18 would send routes only for areas 1 and 2 on the Ethernet.

You can filter on both ends of an adjacency. This adds an extra layer of security against accidental reconfiguration. However, if you set up only one end for filtering, then only that end filters.

Given these filters, the two domains cannot contaminate each other. However, for a node in the intersection, it is not clear which area 3 will be reached when a connection is attempted to node 3.4. It depends on the current route and the circuit costs. Clearly, this is not ideal. It does not matter that there might only be a node 3.4 in domain A and not in domain B. Routing between areas is done solely on the basis of area; only the routers inside an area know the routes to nodes in that area.

Thus, you must establish a second set of filters to decide which instance of an area (domain A or B) is reachable from the intersection for each area not in the intersection. Therefore, you could decide that nodes in the intersection could reach areas 3 and 4 in domain A and area 5 in domain B. In the example, this would be

## Using DNA IV

done by configuring routers 1.18 and 2.21 to only accept routes to areas 3, 4, 6, and 8 from domain A. Routers 2.17 and 2.21 would only accept routes for areas 5 and 9 from domain B.

Therefore, nodes in the intersection see a universe that contains areas 1 and 2 from the intersection, areas 3, 4, 6, and 8 from domain A, and areas 5 and 9 from domain B.

To configure router 1.18 in Figure 19, enter the following NCP commands and parameters:

```
NCP> def mod routing-filter circ eth/0 outgoing area 1,2
NCP> def mod routing-filter circ eth/0 outgoing state on
NCP> def mod routing-filter circ eth/0 incoming area 3,4,6,8
NCP> def mod routing-filter circ eth/0 incoming state on
NCP> def mod routing-filter circ ppp/0 outgoing area 1,2
NCP> def mod routing-filter circ ppp/0 outgoing state on
NCP> def mod routing-filter circ ppp/0 incoming area 3,4,6,8
NCP> def mod routing-filter circ ppp/0 incoming state on
```

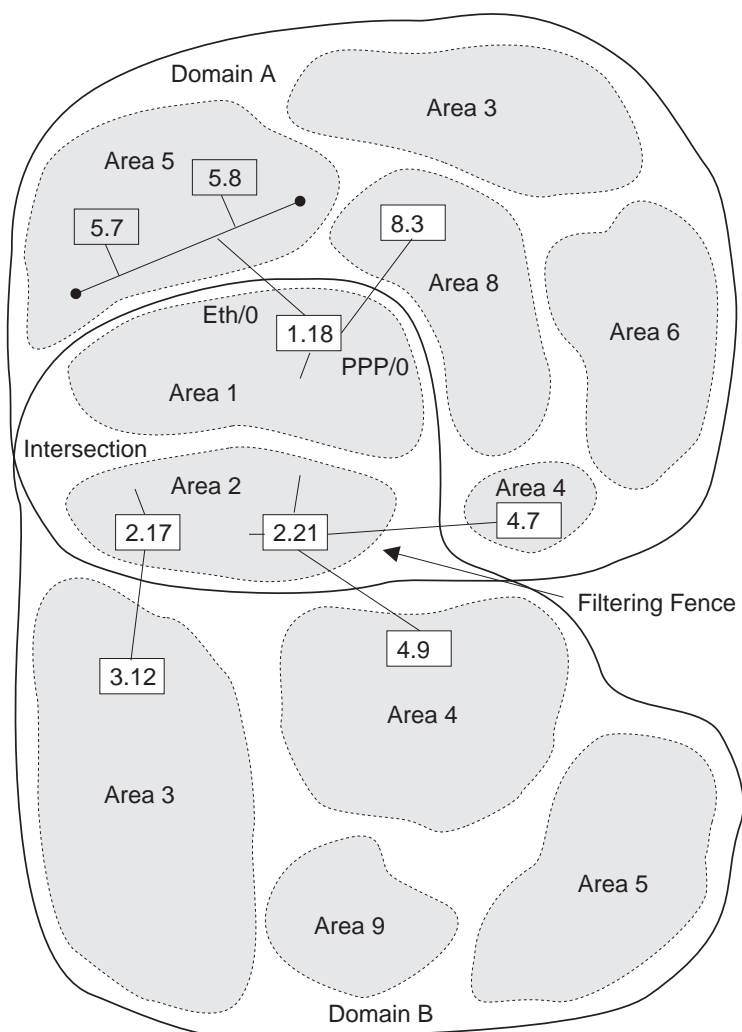

Figure 19. Example of Blending DECnet Domains



There is still no way that a node in domain A area 5 can communicate directly to a node in domain B area 5. For nodes in these two areas to communicate, you must do a series of application-level relays using the **set host** command. For example:

- Run the set host command to remotely login from a node in the domain A area 5 to a node in domain A area 8.
- Run the set host command to remotely login from a node in domain A area 8 to a node in area 1 or 2.
- Run the set host command to remotely login from a node in area 1 or 2 to a node in domain B area 5.

## Configuring DNA IV

The DNA IV protocol runs over Token-Ring, Frame Relay, Ethernet, PPP, and X.25 interfaces. The following sections describe the procedures for configuring the DNA IV protocol to work over Token-Ring and X.25 interfaces.

**Note:** When operating in mixed DNA IV and DNA V networks, all DNA IV configuring and monitoring must be done from the process described in this chapter.

### DNA IV and DNA V Algorithm Considerations

DNA IV uses a distance-vector routing algorithm. DNA V can use either a distance-vector or a link-state routing algorithm. The algorithm that the bridging router selects is according to what protocol is enabled and disabled, and any combinations that can result from these two protocols. (See Table 54.)

*Table 54. DNA IV and DNA V Algorithm Considerations*

DECnet IV Status	OSI/DNA V Status	Algorithm Selected
Enabled	Disabled	Distance-vector (automatically)
Disabled	Enabled	Link-state (automatically)
Enabled	Enabled	Use the <b>set algorithm</b> command to configure this information into SRAM.

### Configuring DNA IV For Token Ring

The procedure to run the DNA IV protocol over 802.5 Token Ring (TR) involves commands from the DNA IV and Token-Ring configuration processes.

1. From the OPCON prompt (\*) enter the configuration process.

```
* talk 6
Config>
```

2. Enter **list device** to see the interface numbers for the Token-Ring interfaces. Note the interface number of each Token-Ring interface.

```
Config> list device
```

3. Use the **network** command with the interface number of the Token-Ring interface you want to configure. This places you in the Token-Ring configuration process.

```
Config> network 0
TKR config>
```

4. Use the **list** command to verify the Token Ring configuration information.

```
TKR config> list
```

```
Token-Ring configuration:
```

```
Packet size (INFO field): 2052
```

## Using DNA IV

```
Speed:                4 Mb/sec
Media:                Shielded

RIF Aging Timer:     120
Source Routing:      Enabled
Mac Address          000000000000
```

5. Exit the Token-Ring configuration process and enter the DNA NCP configuration process.

```
TKR config> exit
Config> protocol DN
NCP>
```

6. Use the **define** command to define a DNA circuit on the Token-Ring interface:

```
NCP> define circuit tkr/0 state on
```

7. Optionally use the **define** command to set the routing type for the circuit. For bilingual or Phase IV support, you need to change the routing type from the default (standard) to either bilingual or AMA.

```
NCP> define circuit tkr/0 router type bilingual
```

or-

```
NCP> define circuit tkr/0 router type AMA
```

8. Use the **list** command to check the parameters.

```
NCP> list circuit tkr/0 characteristics
Circuit Permanent Characteristics
Circuit          = TKR/0
State            = On
Cost             = 4
Router priority  = 64
Hello timer      = 15
Max routers      = 16
Router type      = Standard
```

9. Restart the router, so that all configured parameters take effect.

**Note:** If you want to disable source-routing or set the RIF-timer to a value other than the default value, use the **source-routing** command and the **set RIF-timer** command in the Token-Ring configuration process.

## Configuring DNA IV for X.25

The procedure to run the DNA IV protocol over X.25 circuits involves commands from the X.25 and DNA IV configuration processes.

1. From the OPCON prompt (\*) enter the configuration process. Go to "t 6" and enter X.25 config (net #). If this is the first time X.25 is being configured then do the following:

- a. DEFINE the router's DTE address.

```
X.25 Config> set address
```

- b. DEFINE each protocol that will be supported over X.25:

```
X.25 Config> add protocol
```

**IP** It is usually a good idea to add this protocol so that you can verify the general X.25 configure is OK

**DN**

Note: Allow protocol parameters to default.

- c. DEFINE protocol remote address to the remote X.25 address mapping for the protocols that require this:

```
X.25 Config> add address
```

for IP:

- IP address = 128.185.247.22
- X.25 address = 22

for DN:

- DN address = 5.22
- X.25 address = 22

- d. VERIFY that one end of the X.25 circuit is a DTE and the other end is a DCE.

```
X.25 Config> list all
```

Check the National Personality field for device type. For a national personality type of GTE-Telenet you see:

```
National Personality: GTE Telenet (DTE)
```

-or-

```
National Personality: GTE Telenet (DCE)
```

To change the device type to DCE, enter:

```
X.25 Config> set equipment-type dce
```

Lists all parameters configured for X.25

```
National Personality: GTE Telenet (DTE) National Personality: GTE Telenet (DCE)
```

If not, then chose one router to act as a DCE and modify as such,

```
X.25 Config> set national-personality dce
```

- e. RESTART the router, so that all configured parameters take effect.  
f. To VERIFY that the configuration is valid after a restart, go to the monitor side and observe if the link is coming up.

```
* t 5
+ c
```

This gives you the state of the link at that time. If you see the state of the X.25 link transitions from “testing” to “down”, go to ELS messages and see if there is an obvious error. If the state of the X.25 link transitions from “testing” to “up”, then chances are the x.25 configuration is valid.

2. To VERIFY that the X.25 link is operational:  
a. TRY to PING each end of the X.25 link from the IP monitor:

```
IP> interface
```

Verify that the correct X.25 addresses had been configured in the IP protocol.

```
IP> ping IP address of remote X.25 link
```

3. To CONFIGURE DECnet PhaseIV on the Router:  
a. DEFINE DECnet Executor parameters:

```
NCP> define exec address area.node
Router's DECnet address
```

```
NCP> define exec type DEC-ROUTING-IV
Configures the router as a LEVEL 1 DEC type router
```

## Using DNA IV

**Note:** This example is for configuring a router to interoperate with other routers supporting the DEC-routing standard over X.25 networks. A router supporting the standard must be defined as type DEC-ROUTING-IV (level 1) or DEC-AREA (level 2). The default routing type is ROUTING-IV and AREA which allows interoperation with many existing IBM 2212 and other compatible routers.

```
NCP> define exec state on
```

Restart the router so that when you configure the X.25 circuit, all DEC specific parameters are visible. To verify executor configuration, NCP> **show executor characteristics**

- b. DEFINE PhaseIV X.25 circuits.

You must configure the X.25 circuit as either a PVC or SVC. If this circuit is configured as a PVC then the other end must also be a PVC. If this circuit is configured as an IN-SVC, then the other end must be configured as an OUT-SVC

```
NCP> define cir x25/0 usage IN-SVC
NCP> define cir x25/0 DTE-address "remote X.25 DTE"
NCP> define cir x25/0 call-data
NCP> define cir x25/0 verification enabled
```

Enabling verification is optional.

- c. DEFINE circuits to the active state:

- for Token-Ring

```
NCP> define cir TKR/0 router type bilingual
```

- for ALL circuits

```
NCP> define cir xxx state on
```

Restart the router so that all of the DECnet parameters become effective, VERIFY the X.25 configuration within the DECnet protocol is as you want it.

```
NCP> list circuit x25/0 characteristics
```

---

## Chapter 8. Configuring and Monitoring DNA IV

---

### DNA IV Configuration and Monitoring Commands

This section describes the NCP configuration and monitoring commands. Enter the commands at the NCP> prompt. **All** NCP commands can be accessed from either the configuration or monitoring environments.

*Table 55. NCP Configuration and Monitoring Commands*

Command	Function
? (Help)	Displays all the commands available for this command level or lists the options for specific commands (if available). See "Getting Help" on page xxvi.
define	Defines items in the nonvolatile (permanent) database, including: <ul style="list-style-type: none"><li>• Access control lists and routing filters</li><li>• Circuit items</li><li>• Arguments global to DNA</li><li>• Configuration data from the nodes</li></ul>
purge module	Removes access control lists and routing filters from the permanent database.
set	Sets or changes items in the volatile database, including: <ul style="list-style-type: none"><li>• Circuit items</li><li>• Arguments global to DNA</li><li>• Configuration data from the nodes</li></ul>
show	Displays the status of the volatile database and volatile nodes in the routing database.
show/list	Displays items in the volatile (show) or permanent (list) database, including: <ul style="list-style-type: none"><li>• The current state of the specified circuits</li><li>• The current state of the volatile/permanent database for DNA</li><li>• DECnet access control lists that have been defined in the permanent database for the router</li><li>• DECnet area routing filters that have been defined in the permanent database for the router</li></ul>
zero	Clears circuit counters in the volatile database, global counters in the volatile database, and counters in the access control list module. Does <i>not</i> clear the argument settings made with <b>set</b> or <b>define</b> commands.
Exit	Returns you to the previous command level. See "Exiting a Lower Level Environment" on page xxvi.

**Note the following information about the commands:**

1. The **define** commands do not take effect until the next time the router is started.
2. The **list**, **define**, and **purge** commands modify or display data in the permanent (router's Static RAM) database. The permanent database is stored in the configuration, and remains in effect across restarts, software loads, and power cycles.
3. The **show** and **list** commands are the most useful for monitoring the DNA IV protocol.
4. Use **set**, **show**, and **zero** to modify, display, or clear data in the volatile database.

## DNA IV Configuration and Monitoring Commands

5. The **zero** command clears statistics saved in the volatile database, but does **not** clear the argument settings made with set or define commands.

## Define/Set

This section explains both the **define** and the **set** commands.

Use the **define** command to define access control lists and routing filters, and to define circuit, executor, and node parameters. **Define** is used to set SRAM (needs reboot).

### Syntax:

```
define                circuit-specifier . . .  
                        executor . . .  
                        module access-control . . .  
                        module routing-filter . . .  
                        node . . .
```

**Set** can be used for volatile RAM (immediate change, no reboot).

### Syntax:

```
set                   circuit-specifier . . .  
                        executor . . .  
                        node . . .
```

### **circuit-specifier** *argument*

The *circuit-specifier* options include the following:

#### **active circuits**

Specifies all circuits who are up and whose state is on (set only).

#### **all circuits**

Specifies all circuits on the router.

#### **circuit name**

The name of the circuit. For example: Eth/0, TKR/0, PPP/1.

#### **known circuits**

(**set** only) Specifies all circuits on the router.

The *arguments* include the following:

#### **call-userdata**

Used during circuit initialization of static X.25 circuits. When a circuit is defined as an outgoing SVC, the initial and all subsequent call requests contain the defined call-userdata when the circuit is enabled. When a circuit is defined as an incoming SVC, one of the criteria for accepting an incoming call request is a match of the defined call-userdata.

Currently the call-userdata must be set to the DTE of your local router for both incoming and outgoing SVCs.

Enter an even number of hexadecimal characters (octets) up to a maximum of 14 characters.

## DNA IV Configuration and Monitoring Commands

### cost [range]

Sets the cost to receive a packet on this circuit. This is used by the routing algorithm to determine the cost of a circuit in choosing routes (cost is not the same as an IP metric). Range: 1 to 25. Default: 4.

The following values are suggested starting points:

<i>Circuit type</i>	<i>Cost</i>
Ethernet	4
Token-Ring 4/16	4
Sync 56 Kb	6
Sync T1	5
X.25	25

### Example:

```
define circuit tkr/0 cost 5
```

### DTE Address

Specifies the address of the remote DTE on the X.25 circuit. This is always the address of the remote system. This is a decimal number of up to 14 characters.

### hello timer [range]

Specifies how often (in seconds) router hellos are sent on this circuit. Range: 1 to 8191 seconds. Default: 15 seconds (recommended).

### maximum recalls

(**define** only) Specifies how many attempts the router makes to reestablish an outgoing static SVC call after an initial call failure. After the maximum number of recalls, the router makes no further attempts to establish the SVC without your intervention. Valid values are in the range of 1 to 20, the default is 1. See also the recall timer argument.

### maximum routers [range]

(**define** only) Specifies how many other routers there may be on this circuit. Range: 1 to 33. Default: 16.

**Note:** This parameter is not user-configurable on an X.25 circuit when the executor *type* is set to DEC-routing-IV or DEC-area. In this case the maximum number of routers is 1.

If this is a level 1 router, only routers on this circuit in the same area count. If this is a level 2 router, all routers on this circuit count. The local router does not count against the limit.

The router's efficiency and memory requirements are improved by keeping this number low. Set this argument to equal a few more than the total number of adjacent routers on the circuit. Do not set this argument to less than the number of routers on the circuit; this can result in anomalies in routing.

**Note:** For a point-to-point (synchronous line) circuit, set this argument to 1. The result is significant memory savings on a router with multiple point-to-point lines.

## DNA IV Configuration and Monitoring Commands

The sum of maximum routers over all circuits should be less than the executor maximum broadcast routers argument, although this limit is not strongly enforced.

### recall timer

Determines the delay in seconds between call attempts to establish an X.25 outgoing static circuit.

For **define**, valid values are in the range 1 to 60 seconds. The default is 1 second. See also the argument maximum recalls.

For **set**, valid values are in the range 0 to 65595 seconds. The default is 60 seconds.

### router priority [range]

Specifies the router's priority in bidding to become the designated router for the end-nodes on this circuit. Range: 1 to 127, where 127 is the highest priority. Default: 64.

If two routers have the same priority, the one with the higher node address wins. The router priority has no effect on area routing decisions, or in reaching the closest attached level 2 router.

Use the router priority to choose the designated router to be the one that is most likely to be the best next hop for the end-nodes on the circuit. If there are two routers on a circuit, one with 500 nodes behind it, the other with 20 nodes behind it, the one with 500 nodes should have the higher router priority. This is not required, however, because once a packet from an end-node packet reaches a router, it will be forwarded toward its destination.

This argument is irrelevant on point-to-point lines, where there will be no end-nodes. (A designated router is selected anyway.)

### router type

Specifies the kind of routing that the router needs to perform, standard, AMA, or bilingual.

- *Standard*. Specifies that the router is using conventional phase IV addressing where the MAC address is built from the area and node number. The router defaults to this type.

- *AMA*. Specifies that the router can route packets that use phase IV addressing where the MAC address is arbitrary and learned from the data link layer.

- *Bilingual*. Specifies that the router can route packets that use both conventional and phase IV with AMA addressing.

**state** When set to **on** specifies that the circuit is enabled for use by DNA. When set to **off** specifies that the circuit is disabled for use by DNA. **off** is the default.

**usage** Specifies whether an X.25 circuit is:

- PVC: A permanent virtual circuit
- OUT-SVC: An outgoing static circuit
- IN-SVC: An incoming static circuit

This parameter applies when the executor type is set to *DEC-routing-IV* or *DEC-area*. (See **circuit executor type** for more information.)



## DNA IV Configuration and Monitoring Commands

### verification

Specifies whether the router compares a verification string on the router to verification data in an incoming initialization message. If they do not match, the X.25 circuit must be reinitialized. Specify enabled or disabled.

### executor *argument*

Defines or sets arguments (that is, the executor) global to DNA in the permanent (**define**) or volatile (**set**) database.

Most of these arguments reduce the efficiency of the router, and increase the load on the circuits, as they are made larger. They can also increase memory requirements. They should not be used unnecessarily in excess of the values required for the actual network configuration.

For **set**, the executor must be in the off state to modify numeric arguments or type in the volatile database. (Unlike DECnet-VMS, the **set executor state on** command is valid when the executor state is off.) These changes take place immediately without rebooting the router.

### address [area.node]

Sets the executor's node address, the node ID of this router. Area range: 1 to 63. The area and the node must be less than executor maximum area. Node range is 1 to 1023. The default 0.0 is illegal.

**Note:** DNA will not be enabled if the executor address is not set to a legal value.

### area maximum cost [number]

Maximum cost allowed between this level 2 router and any other level 2 router. If the best route to an area is more costly than this, that area will be considered unreachable. Maximum: 1022. Default: 1022. This argument does not apply to level 1 routers. It should be greater than the maximum legal cost to the most distant area. A suggested value is 25 times "area maximum hops".

### area maximum hops [number]

Maximum number of hops allowed between this level 2 router and any other level 2 router. If the best route to an area requires more hops than this, that area will be considered unreachable. Maximum: 30. Default: 30. This argument does not apply to level 1 routers. It should be about twice the longest path length (in hops) that is expected.

The hop count is used by routing only to speed the decay of routes to unreachable areas. The area maximum hops may be reduced to cause unreachable areas to become unreachable more quickly.

### broadcast routing timer [range]

Specifies how often level 1 (and 2 in a level 2 router) routing messages are sent, in seconds. This is how often they will be sent in the absence of any cost or adjacency changes. This protects the routing database from corruption. At least partial routing updates are sent automatically if any cost or adjacency changes. Range: 1 to 65535. Default: 180. Lower values increase the overhead for this and all adjacent routers. Larger values increase the time required to correct the routing database if a partial routing update message is lost.

## DNA IV Configuration and Monitoring Commands

### **maximum address number [range]**

(**define** only) Is the highest node address (within this area) for which routes will be kept by this router. The routing database will not include routes to nodes in this area with a higher node part of their address. Range: 1 to 1023. Default: 32. It should be higher than the highest node address in the router's area. Setting it excessively large will affect the efficiency of the router, and will use excess memory. This argument does not take effect until the router is restarted.

### **maximum area number [number]**

(**define** only) Is the highest area for which routes will be kept, if this is a level 2 router. The routing database will not include routes to areas higher than this. Maximum: 63. Default: 63. It should be higher than the highest area number in the overall network. This argument does not take effect until the router is restarted.

### **maximum broadcast nonrouters [number]**

(**define** only) Maximum number of end-nodes that can be adjacent (one hop away) to this router. This is the sum over all broadcast circuits. If there are more end-nodes, some of those end-nodes will not be reachable by this router, which may cause unpredictable routing problems. This argument does not take effect until the router is restarted. Range: 1 to 1023. Default: 63.

### **maximum broadcast routers [number]**

(**define** only) Maximum number of routers than can be adjacent (one hop away) to this router. This is the sum over all broadcast circuits. If there are more routers, routes will not be accepted from the excess routers. This may cause unpredictable routing problems. This argument does not take effect until the router is restarted. Default: 32. Maximum: 33 times the number of circuits. This value should be greater than or equal to the sum of "circuit maximum routers" over all circuits, although this is not strongly enforced. This parameter has a strong effect on memory utilization, and should not be set much larger than required. Because the default is rather high, you may need to reduce the value if you have set a large "maximum address."

### **maximum cost [number]**

Maximum cost allowed between this router and any other node in the area. If the best route to a node is more costly than this, that node will be considered unreachable. Maximum: 1022. Default: 1022. It should be greater than the maximum legal cost to the most distant node. A suggested value is 25 times "maximum hops".

### **maximum hops [number]**

Maximum number of hops allowed between this router and any node in the area. If the best route to a node requires more hops than this, that node will be considered unreachable. Maximum: 30. Default: 30. It should be about twice the longest path length (in hops) that is expected. The hop count is used by routing only to speed the decay of routes to unreachable nodes. The maximum number of hops may be reduced to cause unreachable nodes to become unreachable more quickly.

### **maximum visits [number]**

Specifies that any packet forwarded by this router that has been forwarded by more than maximum visits routers will be dropped.

## DNA IV Configuration and Monitoring Commands

This is used to detect packets which are in routing loops, which occur when routes decay. The maximum visits is 63. This is the default. This argument should be larger, by a factor of two, than both maximum hops and area maximum hops.

### **state on**

Enables DNA. May be issued at any time, providing the router has a valid node address.

### **state off**

Disables DNA. May be issued at any time. The default state is off.

For **set**, **set executor** will be inhibited if the DNA initialization failed for lack of available memory for the routing tables.

**type** (**define** only) On X.25 circuits, causes the router to act in one of four ways, depending on the value selected. The options are:

#### **DEC-routing-iv**

configures the router as a DEC-compatible Level 1 router.

#### **DEC-area**

configures the router as a DEC-compatible Level 2 (area) router.

#### **Routing-iv**

configures the router as a Level 1 router without DEC compatibility on X.25 circuits. This is the default.

**Area** configures the router as a Level 2 (area) router without DEC compatibility on X.25 circuits.

A Level 2 router accepts adjacencies with routers in other areas, and maintains routes to all areas. If it can reach other areas, it also advertises itself to Level 1 routers as a route to other areas.

For Level 1 routers, adjacencies are accepted only to routers in the same area.

### **Example:**

```
define executor state on
define executor type DEC-area
define executor maximum broadcast routers 10
```

### **type area**

(**set** only) Causes the router to act as a level 2 router. It will accept adjacencies with routers in other areas, and will keep routes to all areas. If it can reach other areas, it will also advertise itself as a route to other areas to level 1 routers.

The DNA state must be set to *off* before changing the *type*.

### **type routing-IV**

(**set** only) Causes the router to act as a level 1 router, which is the default. Adjacencies will be accepted only to routers in the same area.

The DNA state must be set to *off* before changing the *type*.

### **Example:**

```
set executor state on
```

## DNA IV Configuration and Monitoring Commands

**set executor maximum broadcast routers 10**

### **module access-control** *circuit-specifier argument*

(**define** only) Defines access control lists, which are used to restrict the forwarding of packets between certain origins and destinations. Each access list is associated with one circuit, and applies to DECnet Long Format Data Packets received on that circuit. Access control does not apply to any routing or hello packets.

The arguments for the circuit-specifiers include the following:

#### **all circuits**

Specifies all circuits on the router.

#### **circuit name**

Specifies the named circuit.

#### **known circuits**

Specifies all circuits on the router.

The following items are the arguments you select from after you enter the **define module access-control** command and the circuit-specifier:

#### **state on**

Enables the access control list on this circuit.

#### **state off**

Disables the access control list on this circuit.

#### **type exclusive**

Specifies that any packets matching one or more of the filters in the access control list for this interface will be dropped.

#### **type inclusive**

Specifies that only packets matching one or more of the filters in the access control list for this interface will be forwarded.

#### **filter [source-result source-mask dest-result dest-mask]**

Adds a filter to the list for the specified circuit. The filter is added to the end of the existing list.

The source address is masked with the source-mask, and compared to the source-result. The same is done with the dest-mask and dest-result. The action depends on what type of access control is in use on the circuit.

The following items are the options you select from after you enter the **define module access-control** command and the **filter** circuit-specifier:

#### **source-result**

Address that the source address is compared to after masking.

#### **source-mask**

Mask used for the source address.

#### **dest-result**

Address that the destination address is compared to after masking.

#### **dest-mask**

Mask used for the destination address.

**Example: define module access-control circuit eth/0 state on**

## DNA IV Configuration and Monitoring Commands

### **module routing-filter** *circuit-specifier argument*

(**define** only) Defines routing filters, which are used to restrict the sending of Area routes by level 2 (Executor Type Area) routers.

#### **all circuits**

Specifies all circuits on the router.

#### **circuit name**

Specifies the named circuit.

#### **known circuits**

Specifies all circuits on the router.

The following items are the direction options you select from after you enter the **define module routing-filter** command and the circuit-specifier:

#### **incoming**

Affects the filter on routing information received on this circuit.

#### **outgoing**

Affects the filter on routing information sent on this circuit.

The following items are the arguments you select from after you enter the **define module routing-filter** command and the circuit-specifier:

#### **area [area-list]**

Specifies that the filter allows routing information to pass for the set of areas in the area-list. The area-list is a comma-separated list of areas or ranges of areas. A range is specified by two area numbers separated by a dash. The area-list can also be none, specifying that information will be passed on no areas. The following are area-list examples:

##### **1,4,9,60**

Areas 1, 4, 9, and 60

##### **1-7,9-13,23**

Areas 1, 2, 3, 4, 5, 6, 7, 9, 10, 11, 12, 13, and 23

#### **state on**

Specifies that the filter is active.

#### **state off**

Specifies that the filter is disabled, but continues to be stored in the permanent database. The only way to remove the filter is by using the **purge** command.

**Example: define module routing-filter circuit eth/0 state on**

### **node** *argument*

Allows defining or setting configuring information on nodes into the volatile (**set**) or permanent (**define**) database. The only node for which any information is kept is the executor node, because node names are not stored. The node specifies the router's (executor's) node address. See the **define executor** command description.

**Example: define node state on**

**Example: set node state on**

## DNA IV Configuration and Monitoring Commands

### Purge

Use the `purge` command to remove access control lists and routing filters from the permanent database.

#### Syntax:

```
purge                module access-control . . .  
                    module routing-filter . .
```

#### **module access-control** *circuit-specifier*

Removes access control lists from the permanent database. You can delete an entire access control list; you cannot delete one filter.

#### **all circuits**

Specifies all circuits on the router.

#### **circuit name**

Specifies the named circuit.

**Example: purge module access-control all circuits**

#### **module routing-filter** *circuit-specifier*

Removes routing filters from the permanent database. You can purge a specified filter or you can purge them all.

The options for the circuit-specifiers include the following:

**all** Specifies all routing filters in the configuration memory.

#### **circuit name**

Specifies the routing filter for the named circuit.

**Example: purge module routing-filter all**

### Set

Use the `set` command to add, set, or modify circuit specifiers, global arguments, data link modules, or nodes in the volatile DNA database.

#### Syntax:

```
set                  circuit . . .  
                    executor . . .  
                    node . . .
```

For a description of the options for these arguments, see "Define/Set" on page 248.

### Show

Use the `show` command to show the status of the volatile database and volatile nodes in the routing database.

#### Syntax:

```
show                area-specifier . . .  
                    node-specifier . . .
```

## DNA IV Configuration and Monitoring Commands

### **area-specifier** *argument*

Examines the status of the volatile area routing database. This lets you find out what areas are reachable, and what the routes are to various areas.

The options for the area-specifiers include the following:

#### **active areas**

Provides information on those areas which are currently reachable.

#### **all areas**

Provides information on all areas (up to the executor maximum area).

**area** Provides information on the specified area. If the area is not provided, you will be prompted for it.

#### **known areas**

Provides information on those areas which are currently reachable.

The following items are the subcommand options you select from after you enter the **show** command and the area specifier:

#### **characteristics**

Shows the current state of the specified area. (The same as summary.)

**status** Provides detailed information on the specified areas, including cost and hops.

#### **summary**

Shows the current state of the specified areas. This is the default.

#### **Example.:**

##### **show active areas**

```
Active Area Volatile Summary
Area State      Circuit Next
                Node
1  reachable    Eth/0  1.22
2  reachable    2.26
3  reachable    X25/0  2.30
```

#### **Example:**

##### **show active areas status**

```
Active Area Volatile Status
Area State      Cost Hops Circuit Next
                Node
1  reachable    3    1    Eth/0  1.22
2  reachable    0    0      2.26
3  reachable    2    1    PPP/0  3.9
6  reachable   12    3    PPP/0  3.9
3  reachable   11    1    X25/0  2.30

Area Volatile Status
Area State      Cost Hops Circuit Next
                Node
5  unreachable 1023  31
```

The following items define the information displayed when you use the **show** command.

**area** Indicates the area for this line of the display.

**circuit** Indicates which circuit the next hop to this node will go over. No circuit is given for the router's own area.

**cost** Indicates the cost to this area.

**hops** Indicates the hops to this area.

## DNA IV Configuration and Monitoring Commands

### **next node**

Indicates the router that will be the next hop (intermediate destination) to the specified area.

**state** Indicates that this will be reachable or unreachable.

### **node-specifier** *argument*

Shows the status of the volatile node routing database; this includes information on the reachable nodes and the routes to them.

The node-specifiers can be any of the following:

### **active nodes**

Provides information on all nodes that are currently reachable.

### **all nodes**

Provides information on all nodes (up to the executor maximum address). An all nodes display includes information on the "pseudo-mode" area.0. A route to node area.0 is advertised by any level two router which reaches other areas. Level one routers use these routes to forward all packets to the nearest level one router that knows how to get that packet to the correct area. There is no other way to examine node 0, because it is not a legal node address.

### **node node**

Provides information on the specified node. If the node is not provided, you will be prompted.

### **known nodes**

Provides information on those nodes which are currently reachable.

The arguments include the following:

### **characteristics/ summary**

Both subcommand options show the current state of the specified nodes.

**status** Provides detailed information on the specified nodes, including cost and hops.

### **Example:**

**show node status**

This example shows the detailed status of a specific node.

```
Which node [1.9]? 2.26
Node Volatile Status
Executor node      = 2.26 (gato)
State              = on
Physical address   = AA-00-04-00-1A-08
Type               = DEC-area
```

### **Example:**

**show active nodes**

This example shows the reachable nodes.

```
Active Node Volatile Summary
Executor node      = 2.26 (gato)
State              = on
Identification     = DECnet-MC68360 V1 R2.0 NP00523 [P10]

Node   State   Circuit Next
Address reachable Eth/0   Node
2.14   reachable Eth/0   2.14
2.34   reachable PPP/0   2.34
2.37   reachable PPP/0   2.34
1.22   reachable Eth/0   1.22
```



## DNA IV Configuration and Monitoring Commands

### Example:

```
show adjacent nodes status
```

This example shows the detailed routing information on all adjacent nodes. Only nodes with one hop will be shown. The node type is known and displayed for adjacent nodes only since this information is contained in hello messages only.

```
Adjacent Node Volatile Status
Executor node           = 2.26 (gato)
State                   = on
Physical address        = AA-00-04-00-1A-08
Type                    = DEC-area
Node   State   Type      Cost  Hops  Circuit  Next
Addr
2.14  reachable routing IV    3    1    Eth/0   2.14
2.34  reachable routing IV    2    1    PPP/0   2.34
2.42  reachable nonrouting IV  2    1    PPP/0   2.42
1.22  reachable  area          3    1    Eth/0   1.22
```

## Show/List

Use the **show circuit** command to retrieve information on the current state of the specified circuits from the volatile database. The **list circuit** command retrieves the data that is stored in the permanent data base for circuits.

### Syntax:

```
show                all
                       area
                       circuit . . .
                       executor . . .
                       known argument
                       module argument
                       node argument
```

### Syntax:

```
list  all
        area
        circuit argument
        executor argument
        module
        node argument
```

**circuit-specifier** *argument*

Where the circuit-specifiers options are the following:

#### active circuits

Specifies all circuits that are currently on (per the volatile database).

#### all circuits

Specifies all circuits on the router.

#### circuit name

Specifies the named circuit.

## DNA IV Configuration and Monitoring Commands

### known circuits

Specifies all circuits on the router.

The following items are the subcommand options you select from after you enter the command and the circuit specifier:

### characteristics

Provides detailed information on all of the argument settings for the circuit.

### counters

Shows counters for the circuit.

**status** Shows detailed information on the circuit from the volatile database.

### summary

Shows summary information on the circuit from the volatile database. This is the default if no argument is supplied.

### Example:

#### show all circuits

```
Circuit Volatile Summary
Circuit State      Adjacent
                   Node
X25/0  on          5.25
Eth/0   on          1.22
Eth/0   on          2.14
Eth/0   on          1.13
PPP/0   off
```

### Example:

#### list circuit eth/0 characteristics

```
Circuit Permanent Characteristics
Circuit          = Eth/0
State            = On
Cost             = 4
Router priority  = 64
Hello timer      = 15
Maximum routers  = 16
Router type      = Standard
```

### Example:

#### show active circuits status

```
Active Circuit Volatile Status
Circuit State      Adjacent  Block
                   Node      Size
Eth/0  on          1.22    1498
Eth/0  on          2.14    1498
Eth/0  on          1.13    1498
X25/0  on          5.25    1498
```

### Example:

#### show all circuits characteristics

This example shows the current characteristics of the circuits on this machine. This includes all of the configuration arguments, as well as the current adjacencies, and the Listen timer (three times the adjacency's hello timer).

```
Circuit Volatile Characteristics
Circuit          = Eth/0
State            = on
Designated router = 2.26
Cost             = 4
Router priority  = 64
Hello timer      = 15
Maximum routers  = 16
```

## DNA IV Configuration and Monitoring Commands

```
Adjacent node      = 1.22
Listen timer      = 45
Adjacent node      = 2.14
Listen timer      = 45
Adjacent node      = 2.39
Listen timer      = 90

Circuit            = PPP/0

State              = off
Designated router =
Cost               = 4
Router priority    = 64
Hello timer        = 15
Maximum routers    = 8
```

### Example:

```
show circuit eth/0 counters
```

This example shows the counters that are kept for the circuits. Note that some counters kept by DECnet-VAX are not kept here, but are instead read through the **network** command of GWCON.

```
Circuit Volatile Counters
Circuit = Eth/0
525249 Seconds since last zeroed
 0 Terminating packets received
 0 Originating packets sent
3693 Transit packets received
4723 Transit packets sent
 0 Transit congestion loss
 0 Circuit down
 0 Initialization failure
 0 Packet corruption loss
```

### adjacent node

Node ID of a node that has an adjacency with this node on the circuit being displayed. While adjacencies with end-nodes automatically make that node reachable, a router adjacency does not automatically make that node reachable. A router is not considered reachable unless a routing message has been received over an active adjacency from that router. Thus, nodes may show as adjacent in the circuit database, but will not be in the reachable nodes database (show active nodes).

### block size

Maximum data block size that the associated adjacent node is willing to receive. This is typically 1498 bytes, which is the standard 1500 bytes of an Ethernet packet, less the 2-byte length field used with DECnet.

**circuit** Circuits to which this data applies.

### designated router

Displays what this node believes to be the designated router for this area on this circuit. (There may be some transient disagreements when a new router starts up.) This normally will be the same for all routers on the circuit. End-nodes send all packets for destinations not on the local circuit to their designated router.

### hello timer

Hello timer for this circuit. Router hello messages are sent this often on the circuit.

### listen timer

Amount of time designating how often router or end-node hellos must be received from this adjacency on this circuit. It is three times the hello timer set for this circuit on the adjacent machine.

## DNA IV Configuration and Monitoring Commands

### **router priority**

Router priority for this circuit, used in vying for designated router status.

### **router type**

Router type for this circuit - standard, phase IV with AMA, or Bilingual.

### **maximum routers**

Maximum number of routers allowed on this circuit.

**state** Either ON or OFF. In the volatile database, the state will be ON if the circuit is enabled, and is passing self-test. If the circuit has failed self-test, or the device is not present, the state will be OFF.

In the permanent database, this tells if DNA will try to enable the circuit.

### **executor argument**

Retrieves information on the current state of the volatile database for DNA with the show executor command. The **list executor** command retrieves the data which is stored in the permanent data base for DNA.

The following lists the subcommand options or arguments you select from after you enter the show/list executor command:

### **characteristics**

The detailed information on the settings of all of the adjustable arguments of the routing database.

### **counters**

Gives the global event and error counters for DNA. There are no permanent counters, so the **list executor counters** command is irrelevant.

**status** Gives key information on the state of DNA.

### **summary**

Gives a brief summary on the state of DNA. This is the default.

### **Example:**

#### **show executor**

```
Node Volatile Summary
Executor node      = 2.26 (gato)
State              = on
Identification     = DECnet-MC68360 V1 R2.0 NP00523 [P10]
```

### **Example:**

#### **show executor characteristics**

This example shows the full configuration of the router's database. The **list executor characteristics** command produces essentially the same display.

```
Node Volatile Characteristics
Executor node      = 2.26 (gato)
State              = on
Identification     = DECnet-MC68360 V1 R2.0 NP00523 [P10]
Physical address   = AA-00-04-00-1A-08
Type               = DEC-area
Routing version    = V2.0.0
Broadcast routing timer = 180
Maximum address    = 64
Maximum cost       = 1022
Maximum hops       = 30
Maximum visits     = 63
Maximum area       = 63
Max broadcast nonrouters = 64
Max broadcast routers = 32
```

## DNA IV Configuration and Monitoring Commands

```
Area maximum cost      = 1022
Area maximum hops     = 30
Maximum buffers        = 103
Buffer size           = 2038
```

### Example:

#### **list executor status**

This example shows the status of the router in the permanent database:

```
Node Permanent Status
Executor node       = 2.26 (gato)
State               = on
Type                = DEC-area
```

### Example:

#### **show executor counters**

This example shows the counters that DNA keeps.

```
Node Volatile Counters
Executor node       = 2.26 (gato)
525948 Seconds since last zeroed
  0 Aged packet loss
  0 Node unreachable packet loss
  0 Node out-of-range packet loss
  0 Oversized packet loss
  0 Packet format error
  0 Partial routing update loss
  0 Verification reject
```

The following items define the fields that are displayed when you use the **show/list executor** command.

#### **area maximum cost**

Maximum allowed cost to an area.

#### **area maximum hops**

Maximum allowed hops to an area.

#### **broadcast routing timer**

Frequency of sending routing messages in the absence of any changes.

#### **buffer size**

Buffer size for the router.

#### **executor node**

Node address and node name. The node name is the name set by the CONFIG **set hostname** command.

#### **identification**

Identification of the router software, as sent in MOP System ID messages.

#### **maximum area**

Highest area to which routes are kept.

#### **maximum broadcast nonrouters**

Maximum number of end-nodes that can be adjacent to this router.

#### **maximum broadcast routers**

Maximum number of routers that can be adjacent to this router.

#### **maximum buffers**

Number of packet buffers in the router.

#### **maximum cost**

Maximum allowed cost to a node.

#### **maximum hops**

Maximum allowed hops to a node.

## DNA IV Configuration and Monitoring Commands

### **maximum visits**

Maximum number of routers a packet may be routed through between source and destination.

### **physical address**

Physical Ethernet address set on all Ethernet circuits when DNA starts. Derived from the node ID.

### **routing version**

Version is always Version 2.0.0.

**state** The state of DNA, on or off.

**type** Either ROUTING IV or AREA, corresponding to level 1 and level 2.

### **module access-control circuit-specifier** *argument*

Lists the DECnet access control lists that have been defined in the permanent database for the router, as well as the counters of their use. The options for the circuit-specifiers include the following:

#### **all circuits**

Specifies all circuits on the router.

#### **circuit [name]**

Specifies the named circuit.

#### **known circuits**

Specifies all circuits on the router.

The following items are the arguments you select from after you enter the **show/list module access-control** command and the circuit-specifier:

#### **counters**

Gives counters on the use of the access control lists.

**status** Shows detailed information on the access control lists, including the filters in the access control list.

#### **summary**

Shows summary information on the state of the access control lists. This is the default.

#### **Example:**

```
show module access-control circuit eth/0 counters
```

#### **Example:**

```
list module access-control circuit eth/0 counters
```

```
Module Access-Control Volatile Counters
Circuit = Eth/0
6337      Seconds since last zeroed
0         Packets processed
0         Packets rejected
0         Access control loop iterations
```

### **module routing-filter circuit-specifier** *argument*

Lists the DECnet area routing filters that have been defined in the permanent database for the router.

#### **all circuits**

Specifies all circuits on the router.

#### **circuit [name]**

Specifies the named circuit.

## DNA IV Configuration and Monitoring Commands

### known circuits

Specifies all circuits on the router.

The following items are the arguments you select from after you enter the **show/list module routing-filter** command and the circuit-specifier:

**status** Shows detailed information on the routing filters, including the area list.

### summary

Shows summary information on the state of the routing filters. This is the default.

**Example:** `show module routing-filter circuit eth/0 status`

**Example:** `list module routing-filter circuit eth/0 status`

## Zero

Use the **zero** command to clear circuit counters in the volatile database, global counters in the volatile database, and counters in the access control list module.

### Syntax:

```
zero                circuit-specifier  
                    _  
                    executor  
                    _  
                    module _ access-control circuit-specifier
```

### circuit-specifier

#### all circuits

Specifies all circuits on the router.

#### circuit [name]

Specifies the named circuit.

#### known circuits

Specifies all circuits on the router.

**Example:** `zero all circuits`

### executor

Sets all global counters in the volatile database to a zero value. There are no options.

**Example:** `zero executor`

### module access-control circuit-specifier

#### all circuits

Specifies all circuits on the router.

#### circuit [name]

Specifies the named circuit.

**Example:** `zero module access-control all circuits`

## DNA IV Configuration and Monitoring Commands



---

## Chapter 9. Using OSI/DECnet V

This chapter describes the router's implementation of the International Standards Organization's (ISO) Open Systems Interconnection (OSI) Connectionless Network Layer. DECnet Phase V supports OSI (hereafter called DECnet V/OSI) and users of DNA V networks can use this chapter for information about the ISO OSI protocols. This chapter contains the following sections:

- "OSI Overview"
- "NSAP Addressing" on page 268
- "Multicast Addresses" on page 270
- "OSI Routing" on page 271
- "IS-IS Protocol" on page 271
- "ESIS Protocol" on page 281
- "X.25 Circuits for DECnet V/OSI" on page 281
- "OSI/DECnet V Configuration" on page 283
- "Accessing the OSI Configuration Environment" on page 287
- "DECnet V/OSI Configuration Commands" on page 287

---

### OSI Overview

An OSI network consists of interconnected subnetworks. A subnetwork consists of connected hosts referred to as end systems (ESs) and routers referred to as intermediate systems (ISs), as shown in Figure 20.

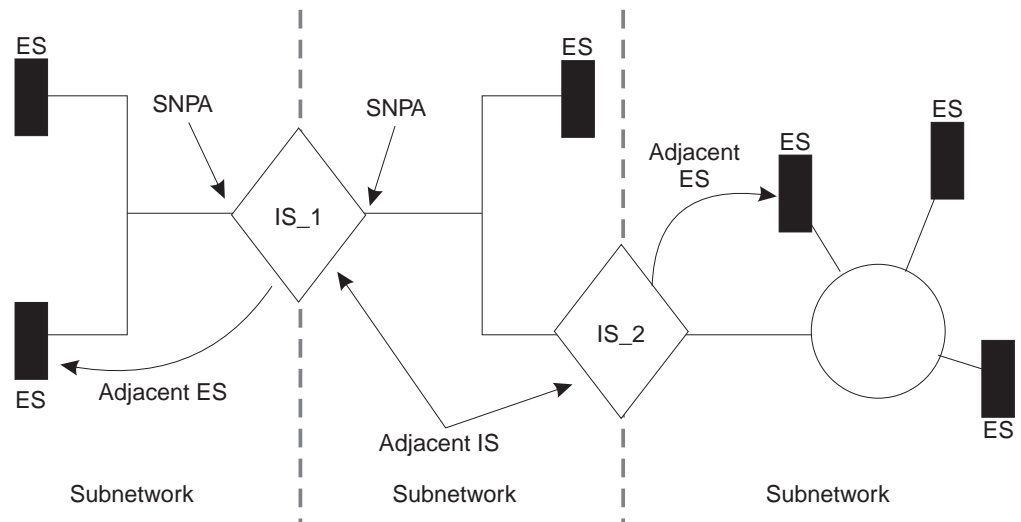

Figure 20. OSI Network

ESs contain all the layers of the OSI reference model and contain the host applications. ISs perform the functions of the lower three layers of the OSI reference model and handle the routing of the network protocol data units (NPDUs) between subnetworks. ISs logically attach to the subnetwork at the subnetwork point of attachment (SNPA). The SNPA is the access point into the data link layer.

## Using OSI/DECnet V

Depending on the IS configuration, each IS can run three protocols: ES-IS, IS-IS, and Connectionless-Mode Network Protocol (CLNP).

The ES-IS protocol enables the ESs and ISs attached to the same subnetwork to dynamically discover each other's existence. An ES connected to the same subnetwork as an IS is adjacent to the IS. The IS-IS routing protocol enables the ISs to do the following:

- Dynamically discover the existence and availability of adjacent ISs.
- Exchange routing information with other ISs.
- Use the exchanged routing information to calculate routes based on the shortest path.

The CLNP protocol is a datagram protocol that transports packets between ISs.

---

## NSAP Addressing

The NPDU contains OSI network addresses (also called NSAPs). The NSAP refers to a point at the network layer where the user accesses the network layer. NSAPs are unique points within a system that represent addressable endpoints of communication through the network layer. The number of NSAPs may vary from system to system.

An addressing authority, such as the United States government's National Institute of Standards and Technology (NIST), administers NSAP addresses and determines how the addresses are assigned and interpreted within their domain. If desirable, these authorities may further partition the domain into subdomains and designate corresponding authorities to administer them.

There are two NSAP addresses within the NPDU, a destination address and a source address. Each address can vary in length from 2 octets to 20 octets and is usually represented in hexadecimal notation. The following is an example of a 6-octet NSAP that can be entered in the OSI configuration of the router.

```
AA000400080C
```

Because the address length is variable, portions of the PDU header called Destination Address Length Indicator and Source Address Length Indicator are used to indicate the length, in octets, of each address.

An NSAP address consists of two parts, an Initial Domain Part (IDP) and a Domain Specific Part (DSP) as shown in Figure 21.

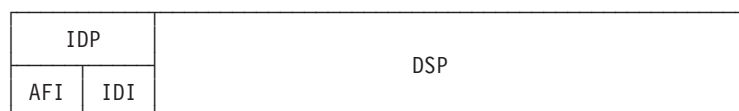

Figure 21. NSAP Address Structure

## IDP

The IDP consists of two parts, the Authority and Format Identifier (AFI) and the Initial Domain Identifier (IDI).

The AFI specifies the type of IDI and the network addressing authority responsible for allocating the values of the IDI.

The IDI specifies both the network addressing domain from which the values of the DSP are allocated and the network addressing authority responsible for allocating values of the DSP from that domain.

## DSP

The network addressing authority identified by the IDI determines the DSP. However, what is important is that the DSP includes specific addressing information for the domain.

## IS-IS Addressing Format

The IS-IS protocol divides the NSAP address into three portions; area address, system ID, and selector (see Figure 22). The area address and system ID, together with a selector of 0, are referred to as the Network Entity Title (NET). A NET is the address of the network layer itself and is assigned when you configure an IS into the OSI network.

IDP	DSP	
Area Address	System ID	Selector

Figure 22. IS-IS NSAP Addressing Interpretation

### Area Address

In the IS-IS protocol, the area address is that portion of the NSAP that includes all or a portion of the IDP and the portion of the DSP up to the system ID.

The area address is that portion of the NSAP that identifies a specific area within a domain. This address must be at least 1 octet long and all ESs and ISs in the same area must have the same area address.

### System ID

The system ID is that portion of the NSAP that identifies a specific system within an area. System IDs must have the following attributes:

- 1 octet to 8 octets in length.
- Equal length throughout the domain. The routers use a default configuration length of 6 octets.
- Unique for each system throughout the domain.

### Selector

The selector is a 1-octet field that acts as a selector for the entity that is to receive the PDU, for example, the transport layer or the IS network layer itself. The router sets this field to 0.

### GOSIP Version 2 NSAPs

Government Open Systems Interconnection Profile (GOSIP) Version 2 provides for government use the NSAP addressing format illustrated in Figure 23. The authorities responsible for the address have clearly defined the fields and specified the addressing format under the DSP set by the National Institute of Standards and Technology (NIST).

IDP		DSP						
AFI 47	IDI 0005	Ver 80	Auth.	Reserved	Domain (2)	Area (2)	Sys. ID (6)	Selector (1)

Figure 23. GOSIP Address Format

- AFI** This 1-octet field has a 47 (hexadecimal) designation. This value signifies that the address is based on the ICD format and that the DSP uses a binary syntax.
- IDI** This 2-octet field has a 0005 (hexadecimal) designation. This value is assigned to the U.S. Government and the format has been established by NIST.
- VER** This 1-octet field has designation of 80 (hexadecimal). This value identifies the DSP format.
- Auth. (Authority)**  
This 3-octet field identifies the authority that controls the distribution of the NSAP addresses.
- Reserved**  
This 2-octet field is provided to accommodate future growth.
- Domain**  
This 2-octet field contains the routing domain identifier.
- Area** This 2-octet field contains the area ID.
- Sys. ID**  
This 6-octet field identifies the system.
- Selector**  
This 1-octet field selects the entity to receive the NPDU.

---

## Multicast Addresses

Multicast addressing is the method that level 1 (L1) and level 2 (L2) ISs use to distribute link-state updates (LSUs) and hello messages to other systems or LANs. When an LSU or a hello message is multicast, a group of destination stations receive the packet. For example, an L1 LSU is multicast only to other L1 ISs. An Intermediate System Hello (ISH) is multicast only to ESs on the same subnetwork.

You can configure multicast addresses for each subnet with the **set subnet** command. Table 56 on page 271 lists the multicast addresses for Ethernet, and Token-Ring.

Table 56. IS-IS Multicast Addresses

Destination	Ethernet 802.3	Token-Ring 802.5	Address	Description
All ESs	09002B000004	C00000004000	9000D4000020	For all end systems on the subnetwork.
All ISs	09002B000005	C00000008000	9000D40000A0	For all intermediate systems on the subnetwork.
All L2 ISs	0180C2000015	C00000008000	800143000028	For all L2 intermediate systems on the subnetwork.
All L1 ISs	0180C2000014	C00000008000	8001430000A8	For all L1 intermediate systems on the subnetwork.

## OSI Routing

OSI routes packets using the IS-IS protocol. Routing with the IS-IS protocol is based on:

- A system ID for routing within an area
- An area address for routing within a domain
- The reachable address prefix for routing outside the domain

The IS-IS protocol uses routing tables to forward packets to their correct destinations. The routing table entries are built from information in the link state database or from user-configured reachable addresses. The link state database is built from information received in the link state update (LSU). Refer to the “Link State Databases” on page 276.

## IS-IS Protocol

The IS-IS protocol is a link state dynamic routing protocol that detects and learns the best routes to reachable destinations. IS-IS can quickly perceive changes in the topology of a domain, and after a short convergence period, calculate new routes. To accomplish this, the IS uses the following packets:

- Link State Updates (LSU) that the IS uses to keep the link state database information current.
- Sequence Number PDU (SNP) to keep the database synchronized and to ensure that each adjacent IS knows what the most recent Link State Packet (LSP) from each other router was.
- Hello messages that ISs use to discover, initialize, and maintain adjacencies with neighboring ISs.

## IS-IS Areas

An IS-IS area is a collection of systems on contiguous subnetworks. Each area's topology is hidden from those of the other areas to reduce routing traffic. A level 1 (L1) IS is used to route within an area. A level 2 (L2) IS is used to route between areas or over the backbone. An IS that routes within an area and over the backbone is considered an L1/L2 IS.

## Using OSI/DECnet V

### IS-IS Domain

An IS-IS domain is a set of rules, administered by the same authority, that all ESs and ISs must follow to ensure compatibility. There are two types of domains that require discussion, administrative domain and routing domain.

#### **Administrative Domain**

An administrative domain controls the organization of ISs into routing domains as well as the NSAP and subnetwork addresses that those routing domains use.

#### **Routing Domain**

A routing domain is a set of ISs and ESs governed by the following rules:

- All devices use the same type of routing metric.
- All devices use the same routing protocol, such as IS-IS.

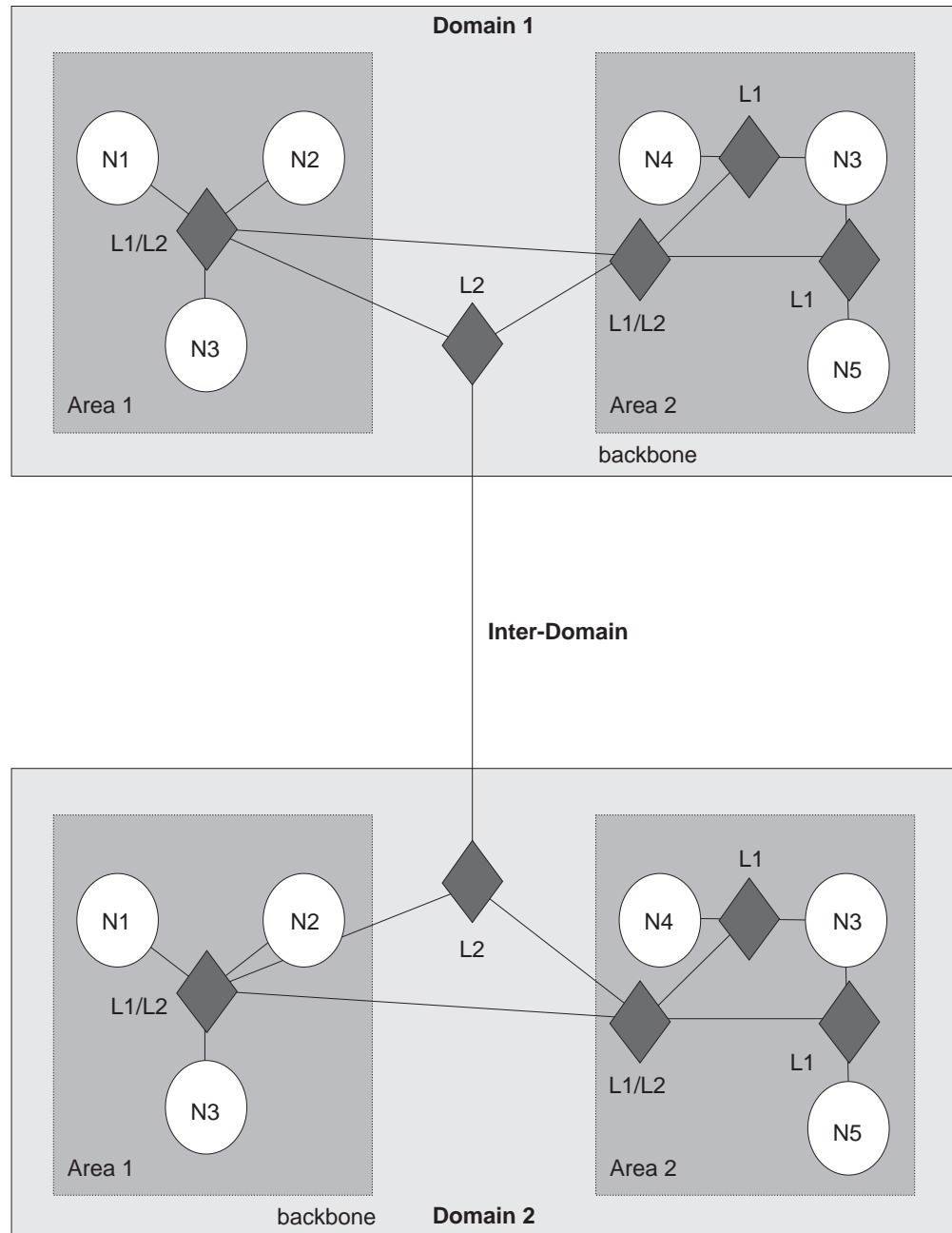

Figure 24. OSI Domain

## Synonymous Areas

When an L1 IS services more than one area, these additional areas are called synonymous areas. A router can support any number of synonymous areas, as long as there is an overlap of at least one area address between adjacent routers. For example, in Figure 25 on page 274, Area 1 and Area 2 are synonymous areas to each other and Areas 3 and 4 are also synonymous to each other.

## Using OSI/DECnet V

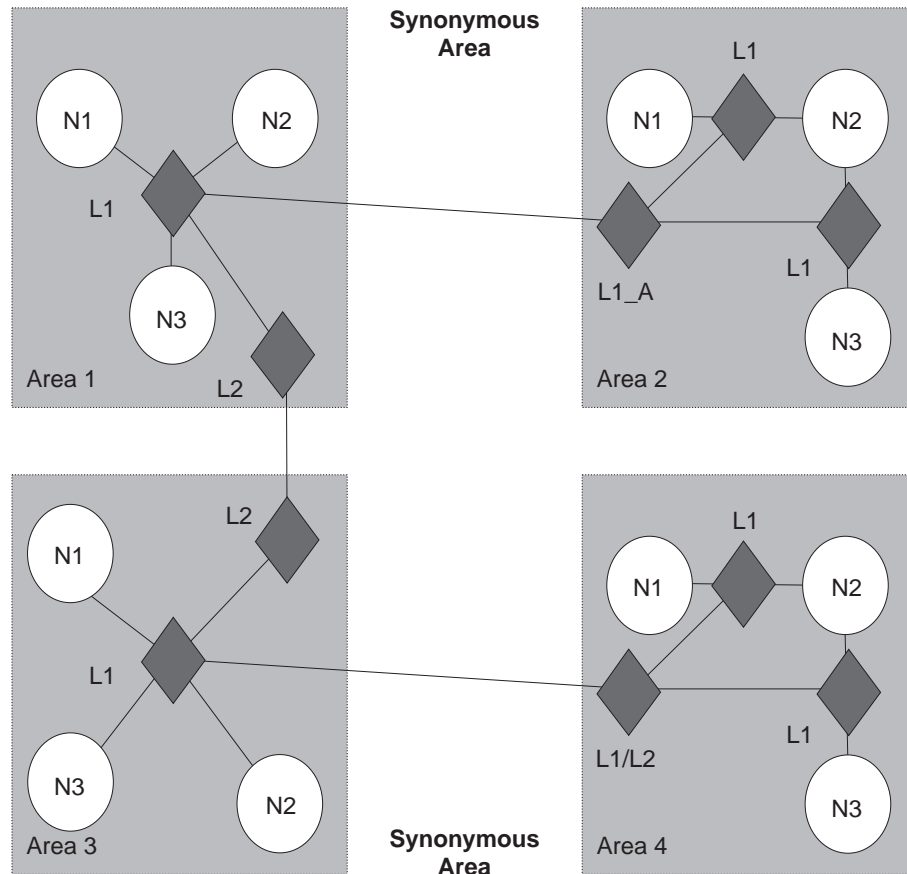

Figure 25. Synonymous Areas

L1\_A IS in area 2 must have area 1's address added to its configuration and the L1 IS in area 1 must have area 2's address added to its configuration. For areas 3 and 4 to be synonymous, each area's address must be added to the others L1 IS.

## IS to IS Hello (IIH) Message

The IIH message enables an IS to determine the existence of other ISs and to establish adjacencies. There are three types of IIH messages: L1, L2, and point-to-point.

Each IS contains a local hello timer and holding timer. Each time the hello timer expires, an IIH is multicast over the IS's interface to any adjacent ISs. When the hello message is received, the recipient establishes or updates (refreshes) the adjacency information. This information remains current for amount of time (seconds) specified by the holding timer. If the holding timer expires, the adjacency is brought down.

## L1 IIH Message

The L1 IIH message is multicast over the interface when its local hello timer expires. The L1 IS places the following information in its IIH:

- Source ID
- Any manual area addresses that it services



- IS type (L1 only, or L1/L2)
- Priority
- LAN ID
- If applicable, the system ID of the L1 designated IS (pseudonode)

Upon receiving this message, the adjacent L1 IS extracts the source ID of the sending IS. This IS then constructs its own IIH message and places its source ID into the source ID field. The sender's source ID is placed into the IS neighbors field. Returning the sender's ID verifies to the sender that the adjacent IS is aware that it exists (2-way adjacency).

When the first IS receives the IIH, it too extracts the source ID and looks at the IS neighbor field. Upon discovering its own source ID in the IS neighbor field, this IS establishes an adjacency with the other IS.

**Note:** Before the adjacent L1 IS can accept the packet, the packet must have a common area address and the same system ID length as the adjacent IS.

### L2 IIH Message

The L2 IIH is multicast over its interfaces for purpose of identifying itself to other L2 ISs. The L2 IS has the same function as an L1 IIH. The L2 IS places the following information in its IIH:

- Source ID
- Any manual area addresses that it services
- IS type (L2 only or L1/L2)
- Priority
- LAN ID
- If applicable, the system ID of the L2 designated IS

**Note:** Before the adjacent L2 IS can accept the packet, the packet must have the same system ID length as the adjacent IS.

### Point-to-Point IIH Message

A point-to-point IIH message is sent out over an IS's non-broadcast interface (Frame Relay or X.25) to identify itself to other ISs. This IS gives the IIH to contain the following information:

- Source ID
- Any manual area addresses that it services
- IS type (L1 only, L2 only, or L1/L2)
- Local circuit ID

### Designated IS

A designated IS is selected among all ISs connected to the same LAN to perform additional duties. In particular it generates link state updates on behalf of the LAN, treating the LAN as a pseudonode. A pseudonode is a method of modeling the entire LAN as a node on the network with fewer logical links. Minimizing logical links throughout the domain lessens the computational complexity of the link-state algorithm.

## Using OSI/DECnet V

When more than one IS exists on a LAN, each IS compares the following to determine which IS will become the designated IS:

- All ISs compare their priorities. The IS with the highest priority becomes the designated IS.
- If the ISs have the same priority, they compare their source MAC addresses. The IS with the numerically highest MAC address becomes the designated IS for that LAN and is indicated through the LAN ID.

## Link State Databases

Each L1 and L2 IS contains a link state database. The primary element of the database is the link state update (LSU). The router is responsible for building its own LSU and processing other ISs' LSUs to maintain the database. The L1 database contains information on ESs. Each L1 database is identical for all L1 ISs in the same area. The L2 database contains information on areas and reachable addresses. Each L2 database is identical for all L2 ISs configured in the IS-IS domain. With information from the databases, the Dijkstra routing algorithm calculates the shortest paths to all destinations and builds the routing tables.

### Link State Flooding

To ensure that each L1 and L2 IS maintains an identical database, LSUs are flooded throughout an area or a backbone. Flooding is a mechanism that an L1 or L2 IS uses to propagate an LSU to all L1 or L2 ISs. An L1 IS floods LSUs to L1 ISs only. An L2 IS floods LSUs to L2 ISs only. An L1/L2 IS accepts both L1 and L2 LSUs.

### L1 Link State Update (non-pseudonode)

The L1 LSU is flooded to all L1 ISs. The L1 IS gives the LSU the following information:

- Source ID
- Any manual area addresses that it services
- IS type (L1)
- System IDs and costs of reaching IS adjacencies
- If applicable, the system IDs adjacent pseudonodes
- System IDs for any manual ES adjacencies

### L1 Link State Update (pseudonode)

The L1 pseudonode LSU is flooded to all L1 ISs located in the area. Any L1 IS located on the same LAN that receives the LSU propagates the LSU to all L1 ISs adjacent on all of its other subnetworks. The L1 IS places the following information in its LSU:

- Source ID
- IS type (L1)
- System IDs and cost of reaching all non-pseudonode ISs located on the LAN
- System IDs for any ES adjacencies learned through the ES-IS protocol

### L2 Link State Update (non-pseudonode)

The L2 LSU is flooded to all L2 ISs. The L2 IS places the following information in its LSU:

- Source ID
- Set of area addresses that it services
- IS type (L2)
- System IDs and the cost of reaching IS adjacencies
- If applicable, the system ID of the pseudonode
- Address prefixes for ISs located in an external domain

### **L2 Link State Update (pseudonode)**

The L2 pseudonode LSU is multicast over the interface and propagated to all L2 ISs located outside the subnetwork. Any L2 non-pseudonode IS located on the same subnetwork that receives the LSU relays the LSU to all L2s located outside the subnetwork. The L2 IS places the following information in its LSU:

- Source ID
- IS type (L2)
- System IDs and metrics for non-pseudonode ISs located on the same subnetwork

### **Attached and Unattached L2 IS**

An attached L2 IS is a router that knows of other areas. An unattached L2 IS is a router that does not know of any areas other than its own.

When routing, an unattached L2 IS routes packets to the closest attached L2 IS.

## **Routing Tables**

An L1-only IS uses one routing table, the level 1 routing table. An L2-only IS contains three routing tables: an L2 area-address routing table, an L2 internal-metric reachable-address-prefix routing table, and an L2 external-metric reachable-address-prefix routing table. An L1/L2 IS contains the L1 routing table and all L2 routing tables. The routing table entries are built from information in the link state database.

### **L1 Routing**

The following summarizes L1 routing:

1. An L1 IS receives a packet and compares the area address portion of the destination address in the header of the packet to the set of area addresses in the router.
2. If the packet is destined for the router's area, the router extracts the system ID from the address. Searching for a match, the router compares the system ID to the system IDs in the L1 routing table.
3. If a match occurs, the IS routes the packet to the ES or the next hop IS. If no match occurs, the packet is dropped.
4. If the packet is not destined for this area, the L1 forwards the packet to the nearest L2 IS or if this router is an L1/L2 IS, it checks its L2 routing tables as described in the next section. If the L1 cannot determine where to route the packet, the packet is dropped.

### L2 Routing

An L2 IS contains three routing tables: an L2 area-address routing table, an internal-metric reachable-address-prefix table (internal), and an external-metric reachable-address-prefix table (external).

The following summarizes L2 routing:

1. An L2 IS receives a packet and compares the destination address in the header of the packet to the set of area addresses in the area address routing table. If a match exists, the packet is forwarded to the next hop backbone router. If no match exists, the router checks the internal routing table.
2. The internal routing table contains entries of reachable address prefixes that lead to other domains. If the internal routing table contains a match, the packet is forwarded along the backbone to the appropriate domain. If no match exists, the router checks the external routing table.
3. The external routing table contains entries to reachable address prefixes that also lead to other domains. If the external routing table contains a match, the packet is forwarded along the path to the appropriate domain. If no match exists, the packet is dropped.

Refer to “Internal and External Routing” for a detailed explanation of the internal and external routing tables.

### Routing Metric

A routing metric is a value associated with a function of the circuit to indicate the cost of routing over that circuit. For example, the routing metric based on the monetary expense of a circuit would use a low number to indicate a low monetary expense and high number to indicate a high monetary expense of routing a packet over that circuit.

The IS-IS routing protocol uses four routing metrics: default metric, delay metric, expense metric, and an error metric.

The current implementation of the OSI protocol uses the IS-IS default metric only. The default metric, by convention, is intended to measure the circuit’s capacity to handle traffic. All ISs in the routing domain must be capable of calculating routes based on the default metric. The other routing metrics are optional. Though they are not used by this implementation of the OSI protocol, they are described below for informational purposes only.

- The delay metric measures the transit delay of the associated circuit.
- The expense metric measures the monetary cost of utilizing the associated circuit.
- The error metric measures the residual error probability of the associated circuit.

### Internal and External Routing

Internal or external routing involves an L2 IS routing a packet between two separate domains. When a packet needs to be routed to another domain, the L2 IS tries to match the address to a reachable address prefix in the internal or external routing table. Internal and external routes are based on the cost (routing metric) to the destination. An internal route’s cost considers the cost of routing within the domain and the cost of routing to the destination. An external route’s cost is based only on the cost of routing to the destination outside the routing domain. The IS chooses the path with the lowest cost.

For example, a packet is destined to go from node A in domain 1 to node D in domain 2 ( Figure 26). Node A can choose two paths to send the packet, to node B and then on to D or to node C and then on to D. How nodes B and C advertise the cost of their routes to D determines how node A decides to route the packet, internally or externally. There are three possible options:

- Nodes B and C advertise the cost of their routes to D as internal. The internal cost of the route A-B-D is 35 which is the cost of routing from A to B, plus the cost of routing from B to D. The internal cost of the route A-C-D is 40, which is the cost of routing from A to C, plus the cost of routing from C to D. Node A in this case would choose to route over the A-B-D path because the cost is lower.
- Nodes B and C advertise the cost of their routes as external. The external cost for A-B-D is 30 which is the cost of routing from B to D. The external cost for A-C-D is 20. Node A in this case would choose to route over the A-C-D path because the cost of this route is lower.
- Nodes B and C advertise the cost of their routes as both internal and external. The internal and external cost of the routes are added to their respective routing tables. Because internal routes are preferred over external routes, the router chooses the internal route of A-B-D.

**Note:** Because there is no exterior routing protocol, all prefix routes between domains must be statically configured.

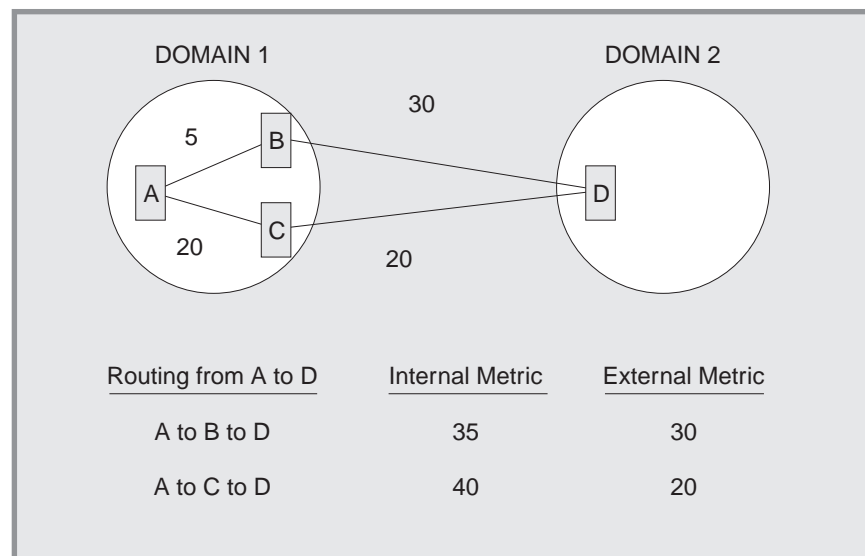

Figure 26. Internal and External Routing Metrics

## Address Prefix Encoding

When entering address prefix routes into the router, carefully consider the difference between encoding rules for NSAPs and for prefix routes. The following four examples illustrate address prefix encoding.

### Encoding a Fixed Length IDI

For many address prefixes, encoding the prefix and the corresponding NSAP is the same. For example, you are using a GOSIP 1.0 address and you want to create a route to an organization in the DoD. The Org IDI is 1234 and the DoD IDI is 0006. The encoded NSAP address is

## Using OSI/DECnet V

4700061234CCCC222222222222

The encoded address prefix is a result of the truncation of the NSAP

4700061234

The encoding rules are about all NSAP formats having a fixed length IDI and to any address prefix ending after the IDP.

### Encoding an AFI

An address prefix based entirely on the AFI is encoded only on the 1 octet AFI field. For example, if an address prefix is needed for all X.121 format addresses (used on X.25 networks), you would use the X.121 AFI of 37.

### Encoding a Variable Length IDI

NSAP addresses that have variable length IDI formats, such as X.121, F.69, E.163, and E.164, use a more complicated encoding scheme. When variable length IDIs are encoded as an NSAP, the address is left padded with zeros; however, when the IDI is encoded as an address prefix, there is no left padding.

For example, you want to route X.25 calls from the U.S. to an X.25 carrier in the Netherlands. The carrier has a Data Network Identifier Code (NDIC) of 2041. The encoding of the address prefix would be

372041

An X.25 subscriber having a national telephone number (NTN) of 117010 on this carrier would have an NSAP of

3700002041117010

Notice that the IDI of the NSAP is left padded with zeros to 14 digits because the resulting international data number (2041117010) was less than 14 digits.

If, however, you want an address prefix that points only to this one X.25 subscriber, the encoding would then be the NSAP (3700002041117010), because the prefix does not end in the IDP.

### Default Address Prefixes

A default address prefix is used when you want to originate a default route to all addresses outside your domain. Default address prefixes are of zero length, so there is nothing to encode.

## Authentication Passwords

To provide a minimum layer of security to the network, OSI provides the option of authentication passwords. When authentication is enabled, any IS-IS packet that does not contain the proper password is not accepted by the IS. The authentication field of the NPDU contains the authentication passwords. There are two types of authentication passwords, transmit and receive.

A transmit password is added to IS-IS packets transmitted by the IS. A receive password is a listing of the transmit passwords that the IS accepts. For example, with authentication enabled, if a transmit password is not added to the packet, or a

listing of the transmit password is not in the receive password database, the packet is dropped. There are three types of transmit and receive passwords: domain, area, and circuit.

A domain password provides security for L2 routing information. An area password provides security for L1 routing information. A circuit password provides security for IS-IS hello messages.

---

## ESIS Protocol

The ES-IS protocol enables ESs and ISs attached to the same subnetwork to dynamically discover each other's existence and availability. This information also permits ESs to obtain information about each other without an available IS.

Route redirection information enables an IS to inform an ES of a better route when forwarding NPDUs to a particular destination. For example, a better route could be another IS on the same subnetwork as the ES, or the destination ES located on the same subnetwork.

## Hello Message

Addressing information is passed on to ESs and ISs through hello messages.

A local configuration timer (CT) and a holding timer (HT) is present on each ES and IS. Each time the CT expires, a hello message is multicast on the LAN. When the hello message is received, the recipient sets its HT value according to the value transmitted in the HT field of the message. The recipient is expected to retain this information until the HT expires to ensure correct operation of the ES-IS protocol.

## End System Hello (ESH) Message

The ESH message is multicast from the ES to all L1 ISs when its local CT expires. The ES constructs this message to inform an IS of any NSAPs that it serves. Upon receiving this message the IS extracts the NSAP and SNPA information and stores the pair in its L1 routing table, replacing any other information currently stored there.

## Intermediate System Hello (ISH) Messages

The ISH message is multicast to all adjacent ESs when its local CT expires. The IS constructs this message to inform the ES of its NET. Upon receiving of this message, the ES extracts the NET and SNPA information and stores the pair in one of its local routing tables, replacing any other information currently stored there.

---

## X.25 Circuits for DECnet V/OSI

For X.25 networks, the router establishes X.25 switched virtual circuits (SVCs) on routing circuits.

**Note:** To enable DECnet V/OSI for X.25, you must enter the DECnet IV process and define your router to be a DEC-AREA or DEC-ROUTING-IV router. You must do this (and restart the router!) to enable the commands to do the DECnet V/OSI configuration. Use the **define executor type** command.

## Using OSI/DECnet V

### Routing Circuits

Routing circuits are point-to-point connections between nodes that implement the ISO CLNS protocol. The router employs these types of routing circuits:

- Static incoming circuits
- Static outgoing circuits
- Dynamically assigned circuits

Static incoming and static outgoing circuits have only one SVC associated with them, and they carry both user data and non-user data (such as routing protocol messages). You bring static circuits up and down explicitly using DECnet V/OSI configuration commands. Dynamically assigned routing circuits are established upon data arrival and are cleared when there is no data being transmitted or received. A dynamically assigned circuit can have multiple SVCs, but can carry only user data.

DECnet V/OSI controls calls for each of the types of routing circuits by using *filters* and *templates*. Filters are used to process incoming calls; templates are used to establish outgoing calls.

### Filters

A *filter* is a collection of user-configurable parameters that define the criteria for accepting all incoming calls for the specified X.25 routing circuit.

The parameters defined in a filter include the calling DTE address, a filter priority, and call/user data.

#### Filters and Routing Circuits

Incoming calls can be on a static incoming circuit or a dynamically assigned (DA) circuit. One or more filters may be defined for the same routing circuit. For example, a DA circuit can have multiple adjacencies and more than one filter may be defined for that routing circuit.

#### Filter Priorities

The list of filters for static incoming circuits and DA circuits are intermixed and ordered by descending priority. When an incoming call is received, the router searches the list of filters, highest priority first. To prevent a static circuit from being erroneously assigned to a DA circuit, it is recommended that the filters of all static circuits be assigned a higher priority than the filters of all DA circuits.

#### Filter Constraints on Calls

For a static incoming circuit, the filter should specify a particular calling DTE address, but the first octet of the call/user data must contain the ISO 8473 Protocol Discriminator (129). For correct operation of multiple DA circuits, additional constraints should be configured for each defined filter. This ensures that the selection criteria specified in those filters permit the required distinction to be made between incoming calls.

**Note:** If a DA circuit should incorrectly connect to a static circuit, the architecture makes no attempt to identify the condition or rectify the problem. The usual



“initialization failure” may be generated on the static side due to non-response to its link initialization queries. The static SVC is then subsequently cleared.

### Templates

A template is a collection of user configurable parameters for outgoing calls. It sets the parameters so that the circuit on the remote router accepts the incoming calls. The parameters defined in a template include the calling DTE address and the call/user data.

You can define only one template per outgoing static routing circuit.

### Link Initialization

Link initialization is a procedure proprietary to Digital Equipment Corporation (and is not part of OSI). Link initialization immediately follows SVC establishment. It is used primarily to establish the DECnet relationship with a remote system on a point-to-point link.

On receipt of an Initialization/XID message, verification can be performed on two levels: on a circuit basis or on a system basis. Basically, the process of verification compares the incoming verification data against data specified locally either for the circuit or for the calling system. The verification data appears in the verification data field of the XID message.

**Note:** This release of the router software does not support verification by the system.

---

## OSI/DECnet V Configuration

**Note:** When operating DNA IV networks together with DNA V networks, all DNA IV configuring and monitoring must be done from the DNA IV NCP> configuration process. For information on configuring DNA IV, refer to “Chapter 7. Using DNA IV” on page 231. The use of the term “OSI” in this chapter refers to both the OSI and DNA V environments unless indicated otherwise.

### Basic Configuration Procedure

This section outlines the minimum configuration steps that you are required to perform to get the OSI/DNA V protocol up and running over a LAN (Ethernet or Token-Ring ), X.25 packet switching networks, and Frame Relay. Before beginning any configuration procedure, use the **list device** command from the **config** process to list the interface numbers of the different devices. If you desire any further configuration command explanations, refer to the configuration commands described in this chapter.

**Note:** You must restart the router for new configuration changes to take effect.

Do the following basic configuration procedure before beginning the specialized procedures described in the following sections.

#### Setting the network entity title (NET)

Set the router’s NET using the set **network-entity-title** command. The NET

## Using OSI/DECnet V

consists of the router's system ID and its area address. Use the **list globals** command to verify that the NET is configured correctly.

### Globally enabling OSI

Enable the OSI software to run on the router using the **enable OSI** command. Use the **list globals** command to verify that the OSI protocol is enabled.

## Configuring OSI Over an Ethernet or a Token-Ring LAN

To configure the OSI protocol to run over an Ethernet or over a Token-Ring LAN, set the subnet. There is a one-to-one correspondence between subnetworks and interfaces. Use the **set subnet** command to configure all LAN subnets (Ethernet, Token-Ring, or ). Use the default multicast addresses for Ethernet. When configuring a token-ring, use these addresses:

### Parameter

#### Functional Address 802.5

#### All ESs [09002B000004]

C00000004000

#### All ISs [09002B000005]

C00000008000

#### All L1 ISs [0180C2000014]

C00000008000

#### All L2 ISs [0180C2000015]

C00000008000

Use the **list subnet detailed** or **list subnet summary** command to verify that you have configured the subnets correctly.

## Configuring OSI Over X.25 or Frame Relay

To configure the OSI protocol to run over the X.25 or Frame Relay interface, do the following:

### Set the subnet

Use the **set subnet** command to set the interface to X.25 or FRL (Frame Relay). Use the defaults for all the required information. Use the **list subnet detailed** or **list subnet summary** command to verify that you have configured the subnets correctly.

### Set the virtual-circuit

Use the **set virtual-circuit** command to configure an X.25 or a Frame Relay virtual circuit.

**Note:** The router will prompt you for a DTE address. For frame relay, enter the DLCI (Data Link Control Identifier) number. For X.25 the enter the PSN's DTE address.

## Configuring a DNA V Router for a DNA IV Environment

When configuring a DNA V router, you may need to configure an interface to run in a DNA IV environment. For example, the router is attaching to both a DNA V and DNA IV network, or a DNA IV ES is attached to a DNA V router.

Before beginning the steps below, use the appropriate preceding section to configure OSI over a LAN, X.25, or Frame Relay.

1. Enter the DN configuration process. Exit `OSI config>` and enter `NCP>`. Use the **protocol DN** command.
2. Define the global DNA address. Use the **define executor address** command to configure the DNA node and area number of the router.
3. Globally enable DNA. Use the **define executor state** command to enable the DNA protocol to run on the router.
4. Enable inter-area routing. If the L2 routing algorithm is distance vector at level 2, use the **define executor type area** command to ensure that this router can exchange DNA IV level 2 routing information.
5. Enable the DNA IV circuit. Enable the circuit that the router will use to exchange the routing information. Use the **define circuit type state on** command.

### DNA IV and DNA V Algorithm Considerations

DNA IV uses a distance-vector routing algorithm. DNA V can use either a distance-vector or a link-state routing algorithm. The algorithm is selected according to what is enabled and disabled, and combinations that can result from these two protocols:

#### **DNA IV disabled and OSI/DNA V enabled**

This combination is considered a pure OSI/DNA V environment and the algorithm is automatically set to link-state at both levels 1 and 2 regardless of how the **set algorithm** command is configured.

#### **DNA IV enabled and OSI/DNA V disabled**

This combination is considered a pure DNA IV environment and the algorithm is set automatically to distance-vector regardless of how the **set algorithm** command is configured.

#### **DNA IV enabled and OSI/DNA V enabled**

This is a mixed environment and the algorithm information is configured and read out of SRAM. Use the **set algorithm** command to configure this information into SRAM.

## Using OSI/DECnet V



## DECnet V/OSI Configuration Commands (Talk 6)

area...  
filter...  
prefix-address  
receive-password  
routing-circuit...  
template...

**alias** Adds an ASCII string that designates a particular area address or system ID. The ASCII string can be *a-z*, *A-Z*, *0--9*, a few other characters including the hyphen ( - ), comma ( , ), and underscore ( \_ ). Do not use escape characters.

The offset indicates the position, in semi-octets (nibbles), where the ASCII string begins within the address (aliases used for system IDs have an offset of 1). The string must be the same size or longer than the segment it is designating or you will receive an invalid segment length message. The maximum allowable alias is 20 bytes.

**Note:** When using an alias input, you must surround it with brackets. For example: **I1\_update 47[newname]99999000012341234.**

### Example:

```
add alias
Alias [ ]:
Segment [ ]:
Offset [1]:
```

**Alias** The character string you want to use

### Segment

The NSAP segment that the alias is replacing

**Offset** The location of the alias (in 4-bit, semi-octets) within the NSAP. The offset is determined from the beginning (left) of the NSAP as it is displayed on the terminal.

### area *area-addr*

Adds additional area addresses (18-byte maximum) that the node supports. An L1 node that supports other areas considers those synonymous areas. One area address is the area portion of the configured NET. If you try to add a duplicate area address, the router will display an error message.

### Example:

```
add area 47000580999999000012341234
```

**Note:** When adding synonymous areas to an L1 node, use the **set globals** command to configure the maximum number synonymous areas allowed for this node. All routers within an area must use the same maximum number of synonymous areas. Adjacencies can not be established if they are different.

### filter *filter-name routing-circuit-name calling-DTE call-UserData priority*

Adds parameters upon which the router bases its acceptance of incoming X.25 calls on an routing circuit, either a static incoming or dynamically assigned (DA) circuit.

The *filter-name* is the name you give the filter. The *routing-circuit-name* is the name of the routing circuit with which the filter is associated.

## DECnet V/OSI Configuration Commands (Talk 6)

The *calling-DTE* is the address of the calling router.

The local router checks the DTE address of an incoming call against a prioritized list of filters for all circuits. A higher filter *priority* in the list means that a connection to that filter's calling DTE address is made first. It is recommended that you assign a higher priority to filters for static circuits than for DA circuits. This can prevent an incoming static call from being assigned a DA circuit.

The *call-UserData* can have one of three values - *osi*, *dec*, or *user*.

- For *osi*, the router automatically configures an ISO protocol discriminator for the call data and requires the call to be from an OSI node.
- For *dec*, the router expects the incoming calls to be from a Digital Equipment Company router.
- For *user*, you are prompted for an additional entry of up to 16 octets. Enter text to constrain the acceptance of incoming calls. The *call-UserData* field of the incoming call must match the specified text.

### Example:

```
add filter
Filter Name [ ]:
Routing Circuit Name [ ]:
DTE Address [ ]:
Call UserData (OSI/DEC/USER):
```

If you select **user**, and additional prompt appears for you to enter user data, followed by a Priority prompt:

```
(max 16 octets) [ ]?
Priority (1-10) [5]?
```

### prefix-address

Adds static routes to destinations outside the IS-IS domain. This parameter prompts you for different information depending on the type of subnet (X.25, LAN, or FRL) that was configured using the **set subnet** command.

**Note:** If no Address Prefix is entered, the default prefix is assumed.

### Example:

#### LAN Subnet:

```
add prefix-address
Interface Number [0]:
Address Prefix [ ]:
MAC Address [ ]:
Default Metric [20]:
Metric Type [Internal]:
State [ON]:
```

#### X.25 Subnet:

```
add prefix-address
Interface Number [0]:
Address Prefix [ ]:
Mapping Type[Manual]:
DTE Address[]:
Default Metric[20]:
Metric Type [Internal]:
State [ON]:
```

#### Frame Relay Subnet:

```
add prefix-address
Interface Number [0]:
Address Prefix [ ]:
```

## DECnet V/OSI Configuration Commands (Talk 6)

DTE Address [ ]:  
Default Metric [20]:  
Metric Type [Internal]:  
State [ON]:

**Note:** If the subnet does not exist, you will receive the error message  
Subnet does not exist - cannot define a reachable address.

### Interface Number

Defines the interface over which the address is reached

### Address Prefix

Defines the NSAP prefix (20 bytes maximum).

### MAC Address

Defines the destination MAC address. You must specify this address if the interface corresponds to a LAN subnet. This prompt will only appear if the interface is connected to a LAN subnet.

### Mapping Type

Defines how the destination physical address is determined, manual or X.121.

If manual, the protocol will prompt for the DTE address.

If X.121, the protocol will not prompt you for the DTE address.

The DTE address in this instance is extracted from the NSAP.

### DTE Address

Defines the destination DTE address. You must specify this address if the interface is X.25 and the mapping type is manual. This prompt only appears if the interface is configured for X.25 and the mapping type is manual.

### Default Metric

Defines the cost of the address.

### Metric Type

Defines whether the metric cost is used for external (E) routing or internal (I) routing.

**State** When set to ON, this prefix-address is advertised to other L2 routers. When set to OFF, this is a non-functional prefix-address.

## routing-circuit

Adds a communications channel for X.25 switched virtual circuits (SVCs) that the routing layer uses to send and receive data.

The routing circuit parameter is only applicable if you configure your router as a DEC-type router. You can specify one of these types of routing circuit:

- static-in
- static-out
- dynamically-assigned

A static-in circuit handles incoming X.25 calls. A call filter (see **add filter**) specifies data the router uses to accept or reject incoming calls on the circuit. A static-out circuit initiates outgoing X.25 calls. The router uses a call template (see **add template**) to make outgoing calls. A dynamically-assigned circuit can have multiple SVCs running simultaneously. Unlike static circuits, the router uses a dynamically-assigned circuit only when there is traffic in or out of the router. It closes the dynamically-assigned circuit upon expiration of an idle timer.



## DECnet V/OSI Configuration Commands (Talk 6)

The **add routing-circuit** command prompts you for values for its parameters.

### Example:

```
add routing-circuit
Interface number [0]?
Circuit Name [ ]?
Circuit Type (STATIC/DA) [STATIC]?
Circuit Direction (OUT/IN) [OUT]?
```

If you select **STATIC** and **OUT**, the following additional prompts appear:

```
Recall Timer (0-65535) [60]?
Max Call Attempts (0-255) [10]?
Initial Min Timer (1-65535) [55]?
Enable IS-IS [YES]?
Level 2 only [NO]?
External Domain [NO]?
Default Metric [20]?
ISIS Hello Timer [3]?
Enable DECnetV Link Initialization [YES]?
Modify Receive Verifier (YES/NO) [NO]?
Transmit Verifier (YES/NO) [NO]?
Explicit Receive Verification (TRUE/FALSE) [TRUE]?
```

If you select **STATIC** and **IN**, the following additional prompts appear:

```
Initial Min Timer (1-65535) [55]?
Enable IS-IS [YES]?
Level 2 only [NO]?
External Domain [NO]?
Default Metric [20]?
ISIS Hello Timer [3]?
Enable DECnetV Link Initialization [YES]?
Modify Receive Verifier (YES/NO) [NO]?
Modify Transmit Verifier (YES/NO) [NO]?
Explicit Receive Verification (TRUE/FALSE) [TRUE]?
```

If you select **DA** for the circuit type, the following additional prompts appear:

```
Recall Timer (0-65535) [60]?
Reserve Timer (1-65536) [600]?
Idle Timer (1-65536) [30]?
Max SVCs (1-65535) [1]?
```

### Interface Number

Specifies the logical X.25 interface for this routing-circuit.

### Circuit Name

Sets up the alphanumeric name of this routing-circuit record.

### Circuit Type

Specifies whether this routing circuit is either a **STATIC** circuit or a **DYNAMICALLY ALLOCATED** circuit.

### Circuit Direction

Specifies **IN** or **OUT** to determine whether the **SVC** of the static circuit will be established with an incoming call request or an outgoing call request. In both cases, the **SVC** is initially established upon operator action, but the circuit is not fully enabled until both ends of the circuit have initialized successfully.

### Recall Timer

Defines the time in seconds that an out-static circuit or a **DA** circuit must wait before attempting a new call request. This is a result of the initial call request failing or a subsequent call having been cleared.

### Max Call Attempts

If a call request fails, **Max Call Attempts** defines the maximum

## DECnet V/OSI Configuration Commands (Talk 6)

number of subsequent call requests that are attempted by the out-static circuit before no further attempts are made. At this point, a call failure is logged and operator intervention is required to activate the out-static circuit.

### **Initial Min Timer**

Specifies the amount of time (in seconds) an out-static circuit waits for a link to be initialized (reception of either an ESH or an ISH) after the call request has been accepted. If the initial min timer expires before the link has been fully initialized, the SVC is cleared and an event generated that indicates initialization failure.

### **Enable IS-IS**

Defines whether the IS-IS protocol is enabled on this routing-circuit. When set to ON, the IS-IS protocol is enabled; when set to OFF, the IS-IS protocol is not enabled.

### **Level2 Only**

Specifies if this routing-circuit is used for Level2 routing only.

### **External Domain**

Specifies whether the router transmits and receives messages to and from a domain outside its IS-IS routing domain.

### **Default Metric**

Defines the cost of this address.

### **ISIS Hello Timer**

Defines the time interval between transmission of ISIS hellos.

### **Enable DECnetV Link Initialization**

Defines whether DEC-style link initialization for this circuit is enabled (YES) or not (NO).

### **Modify Receive Verifier**

Specifies verification data to be checked against on receiving an XID when verifying by circuit.

### **Modify Transmit Verifier**

Specifies verification data to be included in the XID.

### **Explicit Receive Verification**

Defines whether verification is by circuit or by system. TRUE specifies verification by circuit, and FALSE specifies by system.

### **Reserve Timer**

Defines the time after the idle timer expires during which the router still considers a remote node on a DA circuit as "active." The router can forward data on the DA circuit until the reserve timer expires.

### **Idle Timer**

Defines the length of time a DA adjacency may be idle (no data transmission) before it is cleared.

### **Max SVCs**

Defines the maximum number of SVC adjacencies supported by this DA circuit. If no call can be placed because the maximum SVC adjacencies has been reached, then an event "Exceed Max SVC adjacencies" is generated.

### **receive-password**

Adds an ASCII character string (16 characters maximum) that authenticates all incoming packets. An incoming packet whose password matches one of

## DECnet V/OSI Configuration Commands (Talk 6)

the set of receive-passwords is processed through the IS; any incoming packets whose passwords do not match are dropped.

### Example:

```
add receive-password
```

**Note:** You get an error message if you use an invalid *password type*.

```
Password type [Domain]:  
Password [ ]:  
Reenter password:
```

### Password type

Designates one of the two types of passwords, *domain* or *area*.

Domain passwords are used with L2 LSPs (Level 2, Link State Packets) and SNPs (Sequence Number PDU).

Area passwords are used with L1 LSPs and SNPs.

### Password

Designates the character string that you are using for authentication. Maximum allowable string is 16 characters.

**template** *template-name routing-circuit-name destination-DTE call-UserData*  
Creates a template by which the router makes outgoing calls on a static-out routing circuit. Templates for static-out circuits are analogous to filters for static-in circuits.

The *template-name* is the name you give the template. The *routing-circuit-name* is the name of the routing circuit with which the template is associated.

The *destination-DTE* is an address for the remote router of up to 14 digits.

The *call-UserData* must match the call data set up for a filter on the remote circuit. *Call-UserData* can have one of three values - *osi*, *dec*, or *user*.

- For *osi* the router automatically configures an ISO protocol discriminator for the call data and requires the call to go to an OSI router.
- For *dec* the user data identifies the outgoing calls as coming from a Digital Equipment Company router.
- For *user* you are prompted for an additional entry of up to 16 octets. Enter text to match the user data of the appropriate filter on a remote router.

### Example:

```
add template  
Template Name []?  
Routing Circuit Name []?  
DTE Address []?  
Call UserData (OSI/DEC/USER) ?
```

If you choose **user** this additional prompt appears:

```
(max 16 octets) [] ?
```

Enter up to 16 octets of text for user data.

## Change

Allows you to modify the parameters of ISO/DNV records created in the permanent database.

## DECnet V/OSI Configuration Commands (Talk 6)

### Syntax:

```
change                filter
                        prefix-address
                        routing-circuit
                        template
```

### **filter** *filter-name*

Changes the values for routing circuit filter parameters. You can enter a filter name or let the router prompt you for the filter name.

The values in brackets [] are the current values for the parameters; the configured value read from the permanent database.

#### **Example: change filter**

```
Filter Name [currentvalue]?
DTE Address [currentvalue]?
Call Userdata (OSI/DEC/USER)? [currentvalue]?
```

If you select **user**, this additional prompt appears for you to enter user data; followed by a Priority prompt:

```
(max 16 octets) [currentvalue] ?
```

### **prefix-address**

Changes the address data for subnets. The router prompts you for the address data.

#### **Example: change prefix-address**

##### **LAN Subnet:**

```
Interface Number [0]:
Address Prefix [ ]:
MAC Address [ ]:
Default Metric [20]:
Metric Type [Internal]:
State [ON]?
```

##### **X.25 Subnet:**

```
Interface Number [0]:
Address Prefix [ ]:
Mapping Type [Manual]:
DTE Address [ ]:
Default Metric [20]:
Metric Type [Internal]:
State [ON]?
```

##### **Frame Relay Subnet:**

```
Interface Number [0]:
Address Prefix [ ]:
DTE Address [ ]:
Default Metric [20]:
Metric Type [Internal]:
State [ON]?
```

##### **Interface Number**

Indicates the interface over which the address is reached.

##### **Address Prefix**

Indicates the destination NSAP prefix (20 bytes maximum).

##### **MAC Address**

Indicates the destination MAC address. You must specify this address if the interface corresponds to a LAN subnet. This prompt will only appear if the interface is connected to a LAN subnet.

## DECnet V/OSI Configuration Commands (Talk 6)

### Mapping Type

Indicates how the destination physical address is determined, *manual* or *X.121*.

If *manual*, the protocol prompts you for the DTE address.

If *X.121*, the protocol will not prompt you for the DTE address.

The DTE address in this instance is extracted from the NSAP.

### DTE Address

Defines the destination DTE address. You must specify this address if the interface is *X.25* and the mapping type is *manual*. This prompt only appears if the interface is configured for *X.25* and the mapping type is *manual*.

### Default Metric

Indicates the cost of the address.

### Metric Type

Indicates whether the metric cost is used for external (E) routing or internal (I) routing.

**State** When set to *ON*, this address will receive packets. When set to *OFF*, this is a non-functional address.

### **routing-circuit** *routingcircuitname*

Changes the values of the configuration for a routing circuit. You can enter a routing circuit name or let the router prompt you for a name. The values in brackets [] are the current values taken from the permanent database.

#### **Example: change routing-circuit**

```
Routing Circuit Name [currentvalue]?
Recall Timer (0-65535) [currentvalue]?
Max Call Attempts (0-255) [currentvalue]?
Initial Min Timer (1-65535) [currentvalue]?
Enable ES-IS [currentvalue]?
Enable IS-IS [currentvalue]?
Level 2 only [currentvalue]?
External Domain [currentvalue]?
Default Metric [currentvalue]?
ISIS IS Hello Timer [currentvalue]?
ISIS Hello Timer [currentvalue]?
Enable DECnetV Link Initialization [currentvalue]?
Modify Receive Verifier (YES/NO) [currentvalue]?
Modify Transmit Verifier (YES/NO) [currentvalue]?
Explicit Receive Verification (TRUE/FALSE) [currentvalue]?
```

### **template** *template-name*

Changes the values of the template for a static-out routing circuits. You can enter a template name or let the router prompt you for a template name. The values in brackets [] are the current values for the parameters; the configured values read from the permanent database.

#### **Example: change template**

```
Template Name [currentvalue]?
DTE Address [currentvalue]?
Call UserData (OSI/DEC/USER)? [currentvalue]
```

If you select **user**, this additional prompt appears for you to enter your user data; followed by a Priority prompt:

```
(max 16 octets) [currentvalue]?
Priority (1-10) [currentvalue]?
```

## Clear

Use the clear command to erase SRAM or to remove the receive or transmit password.

## DECnet V/OSI Configuration Commands (Talk 6)

### Syntax:

```
clear                receive-password
                        sram
                        transmit-password
```

### receive-password

Removes all of the receive-passwords previously configured using the **add receive-password** command.

**Note:** You will receive an error message if you use an invalid password type.

### Example:

```
clear receive
Password Type [Domain]:
```

### Password Type

Specifies the type of password being used, *Domain* or *Area*. Refer to the **add receive-password** command for description of these passwords.

### SRAM

Use this parameter to erase the OSI configuration from SRAM.

**Attention:** Use this command *only* if you intend to erase the configuration.

### Example:

```
clear sram
Warning: All OSI SRAM Information will be erased.
Do you want to continue? (Y/N) [N]:
```

### Transmit-password

Removes the transmit-password previously configured using the **set transmit-password** command. The output for this parameter is the same as that of the receive-password parameter.

**Note:** You will receive an error message if you use an invalid password type.

### Example:

```
clear password transmit
Password Type [Domain]:
```

## Delete

Use the **delete** command to remove parameters previously configured using the **set** or **add** command.

### Syntax:

```
delete                adjacency
                        alias
                        area
                        filter (DEC configuration only)
                        prefix-address
                        routing-circuit
```

## DECnet V/OSI Configuration Commands (Talk 6)

subnet

template (DEC configuration only)

virtual-circuit

### adjacency

Removes a statically configured ES adjacency previously configured with the **set adjacency** command.

#### Example:

```
delete adjacency
Interface Number [0]?
Area Address [ ]?
System ID [ ]?
```

#### Interface number

Indicates the interface of the adjacency.

#### Area address

Indicates the area address of the adjacency.

#### System ID

Indicates the portion of the NET that identifies the adjacency within the area.

**alias** Removes the ASCII string that designates a portion of an area address or system ID.

#### Example:

```
delete alias
ALIAS [ ]?
```

### area address

Removes the area address (*address*) previously configured with the **add area** command.

#### Example:

```
delete area 47000580999999000012341234
```

### filter *filter-name*

Removes a filter record from the permanent database.

#### Example:

```
delete p_systems
```

### prefix-address

Removes the prefix-address previously configured with the **set prefix-address** command.

#### Example: delete prefix-address

```
Interface Number [0]?
Address Prefix [ ]
```

#### Interface number

Indicates the interface number over which the prefix-address is configured.

#### Address Prefix

Indicates the destination NSAP prefix.

#### Interface number

Indicates the interface number over which the PVC is configured.

## DECnet V/OSI Configuration Commands (Talk 6)

### DTE address

Indicates the DTE address of the X.25 network to which you are connecting or the DLCI of Frame Relay network to which you are connecting.

### **routing-circuit** *routing-circuit-name*

Removes an X.25 routing circuit that was established with **add routing-circuit** from the permanent database.

#### Example:

```
delete routing-circuit p_system2
```

### **subnet** *intfc#*

Removes a subnet that was previously configured with the **set subnet** command. *Intfc#* indicates the interface number of the configured subnet.

#### Example:

```
delete subnet 1
```

### **template** *template-name*

Removes the template for a static outgoing routing circuit by which the router generates outgoing X.25 messages from the permanent database.

#### Example:

```
delete template x25_5
```

### **virtual-circuit**

Removes an X.25 or a Frame Relay virtual circuit that was previously configured with the **set virtual-circuit** command.

#### Example:

```
delete virtual-circuit  
Interface number [0]?  
DTE address []?
```

#### Interface number

Interface number over which the virtual circuit is configured.

#### DTE address

DTE address of the X.25 network to which you are connecting or the DLCI of Frame Relay network to which you are connecting.

## Disable

Use the **disable** command to disable those features previously enabled using the **enable** command.

#### Syntax:

```
disable                _osi  
                        _routing-circuit  
                        _subnet
```

**osi** Disables the OSI protocol on the router.

### **routing-circuit** *routing-circuit-name*

Disables the specified routing circuit.

Use the **add routing-circuit** command to set up routing-circuits.

### **subnet** *interface#*

Disables the OSI protocol on the specified subnet (*interface#*).



**Example:**

```
disable subnet 0
```

## Enable

Use the **enable** command to enable the OSI protocol or an OSI subnet.

**Syntax:**

```
enable          _osi
                _routing-circuit...
                _subnet...
```

**osi** Enables the OSI protocol on the router.

**routing-circuit** *routing-circuit-name*

Enables the specified routing circuit.

Use the **add routing-circuit** command to set up routing-circuits.

**Example:**

```
enable routing-circuit p_system2
```

**subnet** interface#

Enables the OSI protocol on the specified subnet (*interface#*).

**Example:**

```
enable subnet 0
```

## List

Use the list command to display the current configuration of the OSI protocol.

**Syntax:**

```
_list          _adjacencies
               _algorithm
               _alias
               _filter (DEC configuration only)
               _globals
               _password
               _phaseivpfx
               _prefix-address
               _routing-circuits (DEC configuration only)
               _subnets
               _templates (DEC configuration only)
               _timers
               _virtual-circuits
```

**adjacencies**

Displays all statically configured ES adjacencies.

**Example:**

## DECnet V/OSI Configuration Commands (Talk 6)

```
list adjacencies
Ifc   Area Address   System ID   MAC Address
0     0001-0203-0405  0001-0203-0405  0001-0203-0405
1     0002-4000-0000  0000-0019-3004
```

**Ifc** Indicates the interface number that connects to the adjacency.

### Area Address

Indicates the area address of this ES adjacency.

### System ID

Indicates the portion of the NET that identifies the adjacency.

### MAC Address

Indicates the MAC address (SNPA) of the adjacency.

## algorithm

Displays the routing algorithm that is configured in SRAM for the DNA V protocol. If you are running the OSI protocol only, this parameter is unsupported.

### Example:

```
list algorithm
Level 1 algorithm LINK STATE
Level 2 algorithm DISTANCE_VECTOR
```

### Level 1 Algorithm

Indicates the current configuration of the routing algorithm for level 1, Link State (default) or Distance Vector.

### Level 2 Algorithm

Indicates the current configuration of the routing algorithm for level 2, Link State or Distance Vector (default).

**Note:** Depending on whether DNA IV is enabled or disabled, the routing algorithm displayed here may be different from what is running on the router.

**alias** Displays the configured aliases and their corresponding address segments.

### Example:

```
list aliases
Alias      Segment      Offset
joplin    AA0004000104      1
moon      0000931004F0      1
trane     000093E0107A      1
```

**filter** Displays the defined filters for X.25 circuits.

### Example:

```
list filters
Rout Cir Name  Filter Name  DTE Addr  Pri  Call Data
routeCir2     filter1      25         5    81
```

## globals

Displays the router's current NET, area addresses, switch settings, global parameters, and timer configuration.

### Example:

```
list globals
DNAV State: Enabled*   Network Entity Title: 4700050001:0000931004F0
Manual Area Addresses:
1. 4700050001   2. 7700050011

Switches:
ESIS Checksum = On           ESIS Init Option = Off
Authentication = Off

Globals:
IS Type = L2                 System ID Length = 6
```

## DECnet V/OSI Configuration Commands (Talk 6)

L1 LSP Size = 1492 bytes	L2 LSP Size = 1492 bytes
Max IS Adjs = 50	Max ES Adjs = 200
Max Areas = 50	Max ESs per Area = 50
Max Ifc Prefix Adds = 100	Max Ext Prefix Adds = 100
Max Synonymous Areas = 3	Max Link State Updates = 100

### OSI State or DNAV State

Indicates if the OSI or DNA V protocol is running on the router.

### Network Entity Title

Indicates the area address and system ID that make up the router's NET.

### Manual Area Addresses

Areas that the router operates within. The first area address reflects the router's configured NET area address. Additional area addresses were added with the **add area** command.

### Globals:

Indicates the currently configured global parameters:

### IS Type

The router's designation in the OSI environment: L1 or L2.

### Domain ID Length

The size (in bytes) of the system ID portion of the NET.

**Note:** All routers throughout the domain must agree on the length of the domain ID.

### L1 LSP Size/L2 LSP Size

Displays the L1 and L2 maximum LSP buffer size.

### Max IS Adjacencies/Max ES Adjacencies

Displays the maximum number of ES and IS adjacencies that are allowed for all circuits.

### Max Areas

Displays the maximum number of areas in the routing domain.

### Max ESs per Area

Displays the maximum number of ESs allowed in one area.

### Max Int Prefix Adds

Displays the maximum number of internal prefix addresses.

### Max Ext Prefix Adds

Displays the maximum number of external prefix addresses.

### Max Synonymous Areas

Displays the maximum number of level 1 areas serviced by this router.

### password

Displays the number of transmit and receive passwords configured for each OSI Domain and Area. You configure receive passwords using the **add receive-password** command. You configure transmit passwords using the **set transmit-password** command.

### Example:

```
list password
Number of Passwords Configured:
  -- Domain --
Transmit = 3
Receive  = 2
```

## DECnet V/OSI Configuration Commands (Talk 6)

```
-- Area --  
Transmit = 4  
Receive = 6
```

### phaseivpfx

Displays the configured DNA phase IV address-prefix that the OSI protocol is using to route packets to a connected DNA IV network.

#### Example:

```
list phaseivpfx  
Local Phase IV Prefix: 49
```

### prefix-address

Displays all the SNPAs for statically configured routes.

#### Example:

```
list prefix:-addresses  
Ifc Type Metric State Address Prefix Dest Phys Address  
0 INT 20 On 470006 302198112233  
1 EXT 50 OFF 470006 302198223344
```

**Ifc** Indicates the interface number where the address can be reached.

**Type** Indicates the type of metric, either internal (INT) or external (EXT).

**Metric** Indicates the cost of the reachable address.

#### Address prefix

Indicates the destination NSAP prefix. This prefix may be 20 bytes long.

#### Dest Phys Address

Indicates the destination DTE address if this interface is X.25 and the configured mapping is manual.

### routing-circuits

Displays a summary of all routing-circuits or details of each routing circuit.

#### Example:

```
list routing circuits  
Summary or Detailed [Summary]? Summary  
  
Ifc Name Type Enabled  
0 routecir1 STATIC-OUT YES  
0 routecir2 STATIC-IN YES  
0 routecir3 DA YES
```

```
Summary or Detailed [Summary]? Detailed
```

```
Routing Circuit Name [] routecir2  
Interface #: 0  
Enabled: YES  
Type: STATIC  
Direction: Incoming  
Initial Minimum Timer: 55  
Enable IS-IS: YES  
L2 Only: NO  
External Domain: NO  
Metric: 20  
IS-IS Hello Timer: 3  
DECnetV Link Initialization: YES  
Receive Verifier:  
Transmit Verifier:  
Explicit Receive Verification: TRUE
```

#### Interface # / Ifc

The logical X.25 interface for this routing-circuit.

**Name** The alphanumeric name of this routing-circuit record.

#### Enabled

Indicates the state of the routing-circuit: YES for enabled, NO for disabled.

## DECnet V/OSI Configuration Commands (Talk 6)

**Type** Indicates whether the circuit is STATIC-IN, STATIC-OUT, or DA (dynamically allocated).

### Direction

Indicates how the router establishes a static routing circuit: by an incoming call request (IN) or an outgoing call request (OUT).

In either case, the SVC is initially established upon operator action, but the circuit is not fully enabled until both ends of the circuit have initialized successfully.

### Initial Min Timer

The amount of time (in seconds) that a static-out circuit waits for a link to be initialized (reception of either an ESH or an ISH) after the call request has been accepted. If the initial min timer expires before the link is fully initialized, the SVC is cleared and an event is generated indicating initialization failure.

### Enable IS-IS

Indicates whether the IS-IS protocol is enabled on this circuit.

### L2 Only

Indicates whether this routing circuit is used for Level2 routing only.

### External Domain

Indicates whether the router transmits and receives messages to and from a domain outside its IS-IS routing domain.

**Metric** Gives the cost of this address.

### ISIS Hello Timer

Gives the time interval between transmissions of ISIS hellos.

### DECnetV Link Initialization

Indicates whether DEC-style link initialization for this circuit is enabled (YES) or disabled (NO).

### Receive Verifier

Displays verification data to be checked against a received XID when verifying by circuit.

### Transmit Verifier

Displays verification data to be included in XIDs when verifying by circuit.

### Explicit Receive Verification

Indicates whether verification is done by the circuit or the system. TRUE indicates verification by the circuit, FALSE indicates verification by the system.

### Subnet *subnet.reprt intfc#*

Displays subnet information.

- *Subnet.reprt* has two options, Summary and Detailed.
  - *Summary* displays information for all configured subnets.
  - *Detailed* displays information for LAN subnets only.
- *Intfc#* is the interface that connects to the subnet.

### Example:

```
list subnet summary
Ifc State Type ESIS ISIS L2 Only Ext Dom Metric EIH (sec) IIH(sec)
0   On  LAN  Enb  Enb  False  False   20     10      3
2   On  X25
3   On  Fr1
```

## DECnet V/OSI Configuration Commands (Talk 6)

- Ifc** Indicates the interface number of the subnet.
- State** Indicates the state of the interface, ON or OFF.
- Type** Indicates the type of subnet: LAN, X25,
- ESIS** Indicates the state of the ES-IS protocol, enabled (Enb) or disabled (Dis).
- ISIS** Indicates the state of the IS-IS protocol, enabled (Enb) or disabled (Dis).
- L2 Only**  
Indicates if the router is operating at level 2 only, yes (true) or no (false).
- Ext Dom**  
Indicates if the router is operating outside the IS-IS routing domain (external domain).
- Metric** Indicates the cost of using this subnet.
- EIH** Indicates the interval at which ES hello messages are sent out over the subnet.
- IIH** Indicates the interval at which IS hello message are sent out over the subnet.

### Example:

```
list subnet detailed
Interface Number [0]? 0

Detailed information for subnet 0:
  ISIS Level 1 Multicast: 018002B000014
  ISIS Level 2 Multicast: 018002B000015
  All ISs Multicast:      009002B000005
  All ESs Multicast:     009002B000004
  Level 1 Priority: 64
  Level 2 Priority: 64
```

### ISIS Level 1 Multicast

Indicates the multicast address to use when transmitting and receiving L1 IS-IS PDUs.

### ISIS Level 2 Multicast

Indicates the multicast address to use when transmitting and receiving L2 IS-IS PDUs.

### All ISs Multicast

Indicates the multicast address to use when receiving ES hellos.

### All ESs Multicast

Indicates the multicast address to use when transmitting IS hellos.

### Level 1 Priority/Level 2 Priority

Indicates the router's priority for becoming the designated router on the LAN.

## templates

Displays a list of templates defined on this router.

### Example:

```
list template
Route Cir Name      Template Name      DTE Addr      Call UserData
routetest2         temptest2         25            81
```

**timers** Displays the OSI/DNA V timer configuration (what is running on the router, OSI, or DNA V).

## DECnet V/OSI Configuration Commands (Talk 6)

### Example:

```
list timers
Timers:
Complete SNP (sec) = 10      Partial SNP (sec) = 2
Min LSP Gen (sec) = 30      Max LSP Gen (sec) = 900
Min LSP Xmt (sec) = 30      Min Br LSP Xmt (msec) = 33
Waiting Time (sec) = 60     DR ISIS Hello (sec) = 1
ES Config Timer (sec) = 10
```

### Timers:

Indicates the configuration of the OSI timers excluding any per circuit timers.

### Complete SNP

The interval between generation of complete SNPs.

### Partial SNP

The minimum interval between sending partial SNPs.

### Min LSP Generation/Max LSP Generation

The minimum and maximum intervals between generations of LSPs.

### Min LSP Transmission

The minimum interval between LSP retransmissions.

### Min Broadcast LSP Transmission

The minimum interval between LSP retransmissions on a broadcast circuit.

### Waiting Time

The time the update process must delay before entering the ON state.

### DR ISIS Hello

The interval between generations of IS-IS hello PDUs if this router is a designated router.

### ES Config Timer

The minimum interval between that an ES must send a hello packet each time an interface comes up.

### virtual-circuits

Displays information about all X.25 virtual circuits.

**Example:** `list virtual-circuits`

## Set

Use the **set** command to configure the router to run the OSI protocol.

### Syntax:

```
set
adjacency
algorithm
globals
network-entity-title
phaseivpfx
subnet
switches
```

## DECnet V/OSI Configuration Commands (Talk 6)

timers

transmit-password (DEC configuration only)

virtual-circuit (IBM 2212 configuration only)

### adjacency

Adds or changes an ES adjacency. Add an ES adjacency for all LAN ESs that do not run the ES-IS protocol.

#### Example:

```
set adjacency
Interface Number [0]:
Area Address [ ]:
System ID [ ]:
MAC Address [ ]:
```

#### Interface Number

Indicates the interface number that connects to the adjacency.

#### Area Address

Indicates the area where the adjacency is located.

#### System ID

Indicates system ID portion of the NET that is used to identify the adjacency.

#### MAC Address

Indicates the MAC address (SNPA) of the adjacency.

### algorithm

**Note:** This is a DNA phase V command. This command will work only if the DNA phase V protocol is included in the software load. This enables you to select the type of routing algorithm that you are using for the DNA routing protocol, link state (DNA V) or distance vector (DNA IV).

#### Example:

```
set algorithm
Level 1 Algorithm [link_state]?
Level 2 Algorithm [distance_vector]?
```

#### Level 1 Algorithm

Selects the type of routing algorithm, link\_state (for DNA V networks) or distance\_vector (for DNA IV networks).

#### Level 2 Algorithm

Selects the type of routing algorithm, link\_state (for DNA V networks) or distance\_vector (for DNA IV networks).

### globals

Configures the global parameters required by the OSI protocol.

#### Example:

```
set globals
IS Type [L2]:
System ID Length [6 bytes]:
Max Synonymous Areas [3]:
L1 LSP Buffer Size [1492 bytes]:
L2 LSP Buffer Size [1492 bytes]:
Max IS Adjacencies [50]:
Max ES Adjacencies [200]:
Max Areas in Domain [50]:
Max ESs per Area [500]:
Max Internal Prefix Addresses [100]:
Max External Prefix Addresses [100]:
Max Link State Updates [100]?
```

#### IS Type (L1 or L2)

Selects the level of the router, level 1 or level 2.



## DECnet V/OSI Configuration Commands (Talk 6)

### System ID Length

Selects the length of the domain ID portion of the NET. This length must be the same for all routers in same domain.

### Max Synonymous Areas

Selects the maximum number of level 1 areas that are serviced by this router.

### L1 LSP Buffer Size

Selects the buffer size of the level 1 LSPs and SNPs originated by the router. Range is 512 to 1492. If the interface packet size is less than what you configured here, OSI will not run, and the router generates the ELS message ISIS.053.

### L2 LSP Buffer

Selects the buffer size of the level 2 LSPs and SNPs originated by the router. Range is 512 to 1492. If the interface packet size is less than what you configured here, OSI will not run, and the router generates the ELS message ISIS.053.

### Max IS Adjacencies

Selects the total number of IS adjacencies allowed for all circuits. This number is used to size the IS adjacency free pool.

### Max ES Adjacencies

Selects the total number of ES adjacencies allowed for all circuits. This number is used to size the ES adjacency free pool.

### Max Areas in Domain

Selects the total number of areas in the routing domain. This number is used to size the L2 routing table.

### Max ESs per Area

Selects the total number ESs in any one area. This number is used to size the L1 routing table.

### Max Internal Reachable Addresses

Selects the number you are using to size the internal metric routing table.

### Max External Reachable Addresses

Selects the number you are using to size the external metric routing table.

### Max Link State Updates

Selects the number you are using to size the link state database.

### network-entity-title

Configures the router's NET. The NET consists of the router's system ID and area address.

#### Example:

```
set network-entity-title  
Area-address [ ]  
System-ID [ ]:
```

### Area-address

Indicates one of area address portion of the router's NET. It is included as the first address in the router's set of manual area addresses. Each area address may be a maximum of 19 bytes.

### System-ID

Defines the portion of the NSAP that identifies this specific router.

## DECnet V/OSI Configuration Commands (Talk 6)

The system ID can be a maximum of 19 bytes, but the length must agree with the domain ID length that you configured with the **set globals** command.

### phaseivpfx

Configures the prefix-address to allow the OSI protocol to route packets to the attached DNA IV network. The default is 49 (hexadecimal).

#### Example:

```
set phaseivpfx
Local Phase IV prefix [49]?
```

### subnet

Adds or changes a subnet. This parameter prompts you for different information depending on the type of subnet that your configuring: X.25, or LAN.

#### Example:

##### X.25 subnet:

```
set subnet
Interface number [0]:
Interface Type [X25]:
```

##### LAN subnet:

```
Interface number [0]:
Interface Type [LAN]:
Enable ES-IS [N]?
Enable IS-IS [N]?
Level 2 Only [N]?
External Domain [N]?
Default Metric [20]:
ESIS IS Hello Timer [10 sec]:
ISIS Hello Timer [3 sec]:
Modify Transmit password [No]?
Modify the set of receive passwords [No]?
L1 Priority [64]:
L2 Priority [64]:
All ESs [0x09002B000004]:
All ISs [0x09002B000005]:
All L1 ISs [0x0180C2000014]:
All L2 ISs [0x0180C2000015]:
```

##### Frame Relay subnet:

```
Interface number [0]:
Interface Type [FRL]:
```

#### Interface number

Binds the subnet to the specified interface.

#### Enable ES-IS

Indicates whether the ES-IS protocol is going to run over the interface, yes (Y) or no (N).

#### Enable IS-IS

Indicates whether the IS-IS protocol is going to run over the interface, yes (Y) or no (N).

#### Interface Type

Indicates the type of subnet: LAN, X.25, and Frame Relay (FRL). LAN includes Ethernet and Token-Ring.

#### Level 2 Only

Indicates whether the subnet should run at level 2 only, yes (Y) or no (N). A no designation allows the router to route over that subnet at both level 1 and level 2.

## DECnet V/OSI Configuration Commands (Talk 6)

### External Domain

Indicates whether the circuit is operating outside the IS-IS routing domain.

### Default Metric

Indicates the cost of the subnet. Cost range 20–63.

### IS Hello Timer

Indicates the period between transmissions of IS hello PDUs.

### ISIS Hello Timer

Indicates the period between transmissions of L1 and L2 IS-IS hello PDUs.

### Modify Transmit password

Removes or changes a circuit transmit password. When you select yes, this option prompts you with the following:

```
Delete or change the transmit password
[change]?
```

### Modify the set of receive passwords

Removes all or adds one circuit receive-password. When you select yes, this option prompts you with the following:

```
Delete all or add 1 receive password
[add]?
```

### L1 Priority/L2 Priority

Indicates the router priority for becoming the designated router on the LAN.

### All ESs

Indicates the multicast address to use when transmitting IS hellos. The default address reflects the ethernet/802.3 multicast address. If you are connecting to a 802.5 LAN, use **C00000004000**.

### All ISs

Indicates the multicast address to use when receiving ES hellos. The default address reflects the ethernet/802.3 multicast address. If you are connecting to a 802.5 LAN, use **C00000008000**.

### All L1 ISs

Indicates the multicast address to use when transmitting and receiving L1 IS-IS PDUs. The default address reflects the ethernet/802.3 multicast address. If you are connecting to a 802.5 LAN, use **C00000008000**.

### All L2 ISs

Indicates the multicast address to use when transmitting and receiving L2 IS-IS PDUs. The default address reflects the ethernet/802.3 multicast address. If you are connecting to a 802.5 LAN, use **C00000008000**.

### switches

Turns the OSI options on or off.

### Example:

```
set switches
ES-IS Checksum Option [OFF]?
ES-IS Init Option [OFF]?
ISIS Authentication [OFF]?
```

### IS-IS Checksum Option

When switched on, the router generates checksums for all sourced ES-IS packets.

## DECnet V/OSI Configuration Commands (Talk 6)

### ES-IS Init Option

When switched on, the router sends a directed IS Hello to a new ES neighbor.

### IS-IS Authentication

If switched on, each IS-IS packet includes the transmit password configured for the domain, area, and circuits. Also, no checking against receive passwords is done.

**timers** Configures the OSI timers, excluding any circuit timers.

### Example:

#### set timers

Complete SNP [10 sec]:

Partial SNP [2 sec]:

Minimum LSP Generation [30 sec]:

Maximum LSP Generation [900 sec]:

Minimum LSP Transmission [5 sec]:

Minimum Broadcast LSP Transmission [33 msec]:

Waiting Time [60 sec]:

Designated Router ISIS Hello [1 sec]:

Suggested ES Configuration Timer (sec) [10]:

### Complete SNP

Selects the interval between the generation of complete sequence number PDUs (SNP) by the designated router on a broadcast circuit.

### Partial SNP

Selects the minimum interval between sending partial sequence number PDUs (SNP).

### Minimum LSP Generation

Selects the minimum interval between successive generations of Link State Packets (LSPs) with the same LSP ID generated by the router.

### Maximum LSP Generation

Selects the maximum interval between LSPs generated by the router.

### Minimum LSP Transmission

Selects the minimum interval between retransmissions of a LSP.

### Minimum Broadcast LSP Transmission

Selects the minimum transmission, in milliseconds, between transmission of LSPs on a broadcast circuit.

### Waiting Time

Selects the number of seconds the update process should delay in the waiting state before entering the ON state.

### Designated Router ISIS Hello

Selects the interval between the generation of IS-IS hello PDUs by the router if the router is the designated router on a LAN.

### Suggested ES Configuration Timer

Sets the option field of the IS hello message that instructs the ES to change the rate at which it sends ES hellos.

### transmit-password

Sets or changes a transmit password.

### Example:

## DECnet V/OSI Configuration Commands (Talk 6)

```
set transmit-password
Password type [Domain]:
Password [ ]:
Reenter password:
```

### Password type

Selects the type of password: *domain* or *area*.

Domain passwords are used with L2 LSPs and SNPs. Area passwords are used with L1 LSPs and SNPs.

### Password

Indicates the character string that your using for authentication. Maximum allowable string can be 16 characters.

### virtual-circuit

Configures an X.25 SVC or PVC, or a Frame Relay PVC.

### Example:

```
set virtual-circuit
Interface Number [0]:
DTE Address [ ]:
Enable ISIS (Y or N) [Y]?
L2 only (Y or N) [N]?
External Domain (Y or N) [N]?
Default Metric [20]:;
ISIS Hello Timer [3 sec]?
Modify transmit password (y or n) [N]?
Modify the set of receive passwords [No]?
```

### Interface Number

Indicates the X.25 or Frame Relay interface over which the virtual circuit is configured.

### DTE Address

Indicates the destination DTE address for X.25 or the DLCI (Data Link Control Identifier) for Frame Relay. This address must be the same as the one defined for the virtual circuit in the X.25 configuration or the Frame Relay configuration.

### Default Metric

Indicates the cost of the circuit.

### Enable IS-IS

Indicates whether the IS-IS protocol is going to run over the interface, yes (Y) or no (N).

### L2 only

Indicates whether the circuit should run at level 2 only, yes (Y) or no (N). A no designation allows the router to route at both level 1 and level 2.

### External Domain

Indicates whether the circuit is operating outside the IS-IS routing domain.

---

## Accessing the OSI/DECnet V Monitoring Environment

For information on how to access the OSI/DECnet V monitoring environment, refer to *Getting Started (Introduction to the User Interface)* in the *Software User's Guide*

---

## OSI/DECnet V Monitoring Commands

This section describes the OSI/DECnet V Monitoring commands. Use these commands to gather information from the database.

## OSI/DECnet V Monitoring Commands (Talk 5)

The monitoring commands either display or modify the volatile database.

Table 58. OSI/DECnet V Monitoring Commands Summary

Command	Function
? (Help)	Displays all the commands available for this command level or lists the options for specific commands (if available). See "Getting Help" on page xxvi.
Addresses	Displays the router's NET and area addresses.
Change Metric	Modifies the cost of a circuit.
CLNP-Stats	Displays OSI CLNP statistics.
DNAV-info	Displays the DNAV Level1 and Level2 routing algorithm currently in effect.
Designated-router	Displays the designated router for the LAN.
ES-adjacencies	Displays all the ES adjacencies in the adjacency database.
ES-IS-Stats	Displays statistics associated with the ESIS protocol.
IS-adjacencies	Displays all the IS adjacencies in the adjacency database.
IS-IS-Stats	Displays statistics associated with the ISIS protocol.
L1-routes	Displays all the L1 routes in the Level 1 database.
L2-route	Displays all the L2 routes in the Level 2 database.
L1-summary	Displays a summary of the level 1 link state database.
L2-summary	Displays a summary of the level 2 link state database.
L1-update	Displays the information contained in L1 link state update packet.
L2-update	Displays the information contained in L2 link state update packet.
Ping-1139	Causes the router to send an echo request to a destination and wait for a reply.
Route	Displays the route a packet takes to a specified destination.
Send echo packet	Encodes an echo request message in the CLNP packet.
Show routing circuits	Displays the state of user-defined routing circuits for the specified interface. Applies when the router is configured as a DEC-style router.
Subnets	Displays all user-defined subnets.
Toggle	Enables or disables the NSAP alias substitution function.
Traceroute	Displays the route a packet travels to its destination.
Virtual-circuits	Displays all user-defined virtual circuits. Applies when the router is configured as an IBM 2212-style router.
Exit	Returns you to the previous command level. See "Exiting a Lower Level Environment" on page xxvi.

## Addresses

Use the **addresses** command to list the router's NET and the area addresses configured for this router.

### Syntax:

**addresses**

### Example:

```
addresses
Network Entity Title:
4700-0500-01 000-9310-04F0
Area Addresses:
4700-0500-01
4900-02
```

### Network Entity Title

Identifies the router. The NET consists of an area address and a system ID.

## OSI/DECnet V Monitoring Commands (Talk 5)

### Area Address

Indicates addresses within the routing domain. The router can have a maximum of three area addresses configured at any one time.

## Change Metric

Use the **change metric** command to modify the cost of a circuit.

### Syntax:

**change metric**

### Example:

```
change metric
Circuit [0]?
New Cost [0]?
```

### Circuit

Indicates the circuit number that you want to change.

### New Cost

Indicates the new cost of the circuit. Range: 1 to 63.

## CLNP-Stats

Use the **clnp-stats** command to display the OSI Connectionless Layer Network Protocol (CLNP) statistics.

### Syntax:

**clnp-statistics**

### Example:

```
clnp-statistics
Received incomplete packet                0
Received packet with bad NSAP length      0
Received packet with bad checksum         0
Received packet with bad version number   0
Received packet with bad type             0
Received packet with expired lifetime     0
Received packet with bad option           0
Received packet with unknown destination  0
Received packet with no segmentation permitted 0
Received data packet cannot be forwarded  0
CLNP input queue overflow                 0
No buffer available to send error packet   0
No route to send error packet             0
Received OK CLNP packet                   0
Cannot forward error packet               0
ISO unknown initial protocol ID          0
Received error packet                     0
Received local data packet                0
Sent error packet                         0
received echo packet - destination unknown 0
cannot send an echo packet, handler error  0
sent ECHO reply packet                    0
sent ECHO request packet                  0
received ECHO Request                     0
received ECHO reply                       0
Error PDU dropped - SP, MS or E/R flag set 0
```

### Received incomplete packet

Indicates that a data packet fragment recognized as an ISO CLNP data packet was received.

## OSI/DECnet V Monitoring Commands (Talk 5)

### **Received packet with bad NSAP length**

Indicates that an ISO CLNP data packet was received with an incorrect NSAP length.

### **Received packet with bad checksum**

Indicates that an ISO CLNP data packet was received with a bad checksum.

### **Received packet with bad version number**

Indicates that an ISO CLNP data packet was received with an incorrect or unsupported version number.

### **Received packet with bad type**

Indicates that an ISO CLNP data packet was received with an incorrect or unsupported type field.

### **Received packet with expired lifetime**

Indicates that an ISO CLNP data packet was received with an expired lifetime.

### **Received packet with bad option**

Indicates that an ISO CLNP data packet was received with a bad optional parameter.

### **Received packet with unknown destination**

Indicates that an ISO CLNP data packet was received but could not be routed. The routing table contains no entry for the destination.

### **Received packet with no segmentation permitted**

Indicates that an ISO CLNP data packet was received that needed segmentation. The segmentation permitted flag was not set.

### **Received data packet cannot be forwarded**

Indicates that an ISO CLNP data packet was received but could not be routed because of a handler error.

### **No buffer available to send error packet**

An attempt to send an ISO CLNP error packet failed because of a lack of system I/O buffers.

### **No route to send error packet**

An attempt to send an ISO CLNP error packet failed because it could not be routed.

### **Received OK CLNP packet**

Indicates that an ISO CLNP data packet was received and passed error checking.

### **Cannot forward error packet**

Indicates that an ISO CLNP error packet could not be routed because of a handler error.

### **ISO unknown initial protocol ID**

Indicates that an ISO CLNP packet was received with an unknown or unsupported initial protocol identifier.

### **Received error packet**

Indicates that an ISO CLNP error packet was received for this router.

### **Received local data packet**

Indicates that an ISO CLNP data packet was received with the destination NSAP indicating one of the router's NSAPs.



**Sent error packet**

Indicates that ISO CLNP error packet was sent on receipt of a bad packet.

**Designated-router**

Use the **designated-router** command to display the designated router for the LAN subnets that are physically attached to this router and actively running IS-IS.

**Syntax:**

**designated-router**

**Example:**

```
designated-router
Designated Router Information:
Hdw  Int#  Circ      L1DR              L2DR
Eth/1 1      2      0000931004F002  0000931004F002
TKR/0 0      1      Elvis-01         Elvis-01
```

**Hdw** Indicates the type and instance of LAN attached to this router.

**Int#** Indicates the interface number of this router that attaches to the LAN.

**Circ** Indicates the circuit number assigned by the router. This number is always one more than the interface number for LAN subnets.

**L1DR** Indicates the LAN ID of the designated router. If the use of an alias is enabled, this command displays the alias of the particular segment. The LAN ID is the designated router's system ID concatenated with a 1-byte locally-assigned circuit ID.

**L2DR** Description is the same as L1DR described above.

**Note:** If the designated router has not been elected yet, "Not Elected" will be displayed instead of a LAN ID.

**DNAV-info**

Use the **dnav-info** command to display the routing algorithm that is currently running on the router.

**Syntax:**

**dnav-info**

**Example:**

```
dnav-info
DNA V Level 1 Routing Algorithm: Distance-vector
DNA V Level 2 Routing algorithm: Distance-vector
```

**Note:** Depending on whether or not DNA IV is enabled or disabled, the routing algorithm displayed here may differ from what is configured in memory using the **set algorithm** command at the OSI/DECnet V config> prompt.

If DNA IV is enabled - the routing algorithm is the one configured in memory.

If DNA IV is disabled - the routing algorithm is set to link state and may differ from that set in memory.

## OSI/DECnet V Monitoring Commands (Talk 5)

### ES-Adjacencies

Use the **es-adjacencies** command to display all the End System (ES) adjacencies that are either configured or learned through the ESIS protocol.

#### Syntax:

**es-adjacencies**

#### Example:

```
es-adjacencies
End System Adjacencies
System ID      MAC Address      Interface  Lifetime  Type
6666-6666-6666 1234-FEAA-041C   0          50        DNAIV
```

#### System ID

The system ID of the ES adjacency.

#### MAC Address

Indicates the MAC address of the ES on the subnet.

#### Interface

Indicates the router's interface number where the ES adjacency was learned.

#### Lifetime

Indicates the amount of time, in seconds, that the router has left before the information received in the last ES Hello message is discarded. In the case of static or a manually configured ES-Adjacency, this field reads **Static**.

**Type** Indicates the type of ES adjacency, OSI, DNAIV, DNAIV', and MANUAL for statically configured adjacencies.

### ES-IS-Stats

Use the **es-is-stats** command to display the statistics for the ESIS protocol.

#### Syntax:

**es-is-stats**

#### Example:

```
es-is-stats

ESIS input queue overflow          0
Received incomplete packet         0
Received packet with bad checksum  0
Received packet with bad version   0
Received packet with bad type      0
No iob available to send hello     0
Cannot send hello due to packet handler error 0
Sent hello                          3672
Received packet with bad header     0
Received hello with bad nsap        0
Received hello packet with bad option 0
Received hello                      0
Received hello with unsupported domain source 0
No resources to install route       0
Received hello with conflicting route 0
Timed out route reactivated         0
No resources to send redirect       0
Redirect not sent - handler error    0
Sent redirect                       0
Timed out route                     0
Timed out route                     0
Unable to allocate resources for a new ES adjacency 0
```

## OSI/DECnet V Monitoring Commands (Talk 5)

```
hello PDU dropped, received over point-to-point circ 0  
ESIS hello PDU dropped, no matching area address 0  
dropped hello packet - manual ES adjacency exists 0
```

### **ESIS input queue overflow**

The ESIS packet was dropped because of a task input queue has overflowed.

### **Received incomplete packet**

A packet fragment recognized as an ESIS packet was received.

### **Received packet with bad checksum**

An ESIS packet with a bad checksum was received.

### **Received packet with bad version**

An ESIS packet with a bad or unsupported version was received.

### **Received packet with bad type**

An ESIS packet with a bad or unsupported type field was received.

### **No job available to send hello**

An attempt to send an ESIS hello failed because of a lack of system I/O buffers.

### **Cannot send hello due to packet handler error**

An ESIS hello could not be sent because of a handler error.

### **Sent hello**

An ESIS hello was sent out an interface.

### **Received packet with bad header**

An ESIS hello packet with a bad holding time or received field was received.

### **Received hello with nsap**

An ESIS hello packet with a bad NSAP or an NSAP that over ran the field was received.

### **Received hello packet with bad option**

An ESIS CLNP data packet was received with a bad option parameter.

### **Received hello**

An ESIS hello packet was received on the interface.

### **Received hello with unsupported domain source**

An ESIS hello packet was received from an unspecified domain source.

### **No resources to install route**

An ESIS hello packet was received, but there were no resources to install the route.

### **Received hello with conflicting route**

An ESIS hello packet was received but could not be entered into the database. A previously-defined static or dynamic route in the database conflicts with the route in the hello.

### **Timed out route reactivated**

An ESIS hello packet with a previously timed out route was received.

### **No resources to send redirect**

An ESIS redirect packet could not sent because of a lack of resources.

### **Redirect not sent handler error**

An ESIS redirect packet could not be sent because of a handler error.

## OSI/DECnet V Monitoring Commands (Talk 5)

### Sent redirect

An ISIS redirect packet was sent out the interface.

### Timed out route

An ISIS hello route has timed out.

### Unable to allocate resources for a new ES adjacency

An ES-IS hello packet was received but the router had insufficient resources to establish an ES adjacency with the sending node.

### hello PDU dropped, received over point-to-point circ

An ES-IS hello packet was dropped because the circuit involved is a point-to-point circuit.

### ISIS hello PDU dropped, no matching area address

An ES-IS hello packet was dropped because the area did not match the router's area address. The ES-IS protocol applies to one area only.

### dropped hello packet-manual ES adjacency exists.

An ES-IS hello packet was dropped because a static ES adjacency exists with the sending node.

## IS-Adjacencies

Use the **IS-adjacencies** command to list all the IS adjacencies that are learned through the ISIS protocol.

### Syntax:

#### is-adjacencies

### Example:

#### is-adjacencies

```
Intermediate System Adjacencies
System ID      MAC Address    Int  Level Usage  State  Life  Type
0000-9310-04C8 AA00-0400-EF04 0    L1   L1/L2 DOWN   5390  OSI
0000-9310-04C8 AA00-0400-EF04 0    L2   L1/L2 DOWN   5390  DNAIV
AA00-0400-0504 AA00-0400-0504 1    L2   L2     UP     5390  OSI
```

### System ID

The system ID of the IS adjacency.

### MAC Address

Indicates the MAC Address of the IS adjacency.

**Int** Indicates the router's interface number that connects to the IS adjacency.

**Level** For LANs this indicates the neighbor system level from type of hello message, L1 or L2. For point-to-point this indicates the neighbor system type L1 only, otherwise L2.

**Usage** Indicates from the hello packet circuit type, L1 only, L2 only, or L1 and L2.

**State** Indicates the operational state of the IS adjacency, up or down.

**Life** Indicates the amount of time, in seconds, before discarding the last IS Hello message.

**Type** Indicates the routing protocol type of the IS adjacency, OSI or DNA IV.

## IS-IS-Stats

Use the **is-is-stats** command to display information associated with the ISIS protocol.

**Syntax:**

**is-is-stats**

**Example:**

**is-is-stats**

Link State Database Information

no. of level 1 LSPs	1	no. of level 2 LSPs	0
no. of L1 Dijkstra runs	21	no. of L2 Dijkstra runs	0
no. of L1 LSPs deleted	0	no. of L2 LSPs deleted	0
no. of routing table entries allocated	6		

Packet Information

level 1 lan hellos rcvd	0	level 1 lan hellos sent	10967
level 2 lan hellos rcvd	0	level 2 lan hellos sent	10967
pnt to pnt hellos rcvd	0	pnt to pnt hellos sent	0
level 1 LSPs rcvd	0	level 1 LSPs sent	40
level 2 LSPs rcvd	0	level 2 LSPs sent	0
level 1 CSNPs rcvd	0	level 1 CSNPs sent	0
level 2 CSNPs rcvd	0	level 2 CSNPs sent	0
level 1 PSNPs rcvd	0	level 1 PSNPs sent	0
level 2 PSNPs rcvd	0	level 2 PSNPs sent	0

**no. of level 1/level 2 LSPs**

Indicates the number of L1 and L2 link state packets that are in the database.

**no. of L1/L2 Dijkstra runs**

Indicates the number of times the router computed the L1 and L2 routing tables.

**no. of L1/L2 LSPs deleted**

Indicates the number of L1 and L2 link state packets that were deleted from the database.

**no. of routing table entries allocated**

Indicates the number of entries the routing table currently holds.

**level 1/level 2 lan hellos rcvd**

Indicates the number of LAN hellos the router has received.

**level 1/level 2 hellos sent**

Indicates the number of LAN hellos that router has sent.

**pnt to pnt hellos rcvd**

Indicates the number of point-to-point hellos that the router has received.

**pnt to pnt hellos sent**

Indicates the number of point-to-point hellos that the router has sent.

**level 1/level 2 LSPs rcvd**

Indicates the number of L1 and L2 link state packets (LSPs) that the router has received.

**level 1/level 2 LSPs sent**

Indicates the number of L1 and L2 LSPs that the router has sent.

**level 1/level 2 CSNPs rcvd**

Indicates the number of L1 and L2 complete sequence number PDUs (CSNPs) that the router has received.

**level 1/level 2 CSNPs sent**

Indicates the number of L1 and L2 CSNPs that the router has sent.

## OSI/DECnet V Monitoring Commands (Talk 5)

### level 1/level 2 PSNPs rcvd

Indicates the number of L1 and L2 partial sequence number PDUs (PSNPs) that the router has received.

### level 1/level 2 PSNPs sent

Indicates the number of L1 and L2 PSNPs that the router has sent.

## L1-Routes

Use the **I1-routes** command to display all the level 1 routes that are in the L1 routing database.

### Syntax:

#### I1-routes

### Example:

```
I1-routes
Level 1 Routes
Destination System ID  Cost  Source      Next Hop
0000-9300-0047         0    LOCArea    *
AA00-0400-080C         1    ESIS       AA00-0400-0C04, Ifc 7
7777-7777-7777         0    ISIS       3455-6537-2215
```

### Destination System ID

Indicates the system ID of the destination host.

**Cost** Indicates the cost of this route.

### Source

Indicates the one of three sources where the router learned of the route: LOCAREA, ESIS, or ISIS.

### Next Hop

Indicates the next hop a packet would take on its route. An asterisk (\*) designation refers to the router itself as the packet's destination. An address with an interface number is either the MAC address of a directly connected ES, or the DTE address if the next hop is an X.25 switch, or a DLCI if the next hop is Frame Relay switch. A system ID (34555372215) refers to the next hop to destination.

## L2-Routes

Use the **I2-routes** command to display all the level 2 routes in the L2 database.

### Syntax:

#### I2-routes

### Example:

```
I2-routes
Level 2 Routes
Destination              Cost  Type      Next Hop
4700-0500-01             0    LOC-AREA  *
4900-02                   20    AREA      0000-9310-04C9
```

### Destination

Indicates the system ID of the destination area or reachable address.

**Cost** Indicates the cost of this route.

**Type** Indicates the four types of routes: LOC-area (local), LOC-prefix, area, prefix/I, and prefix/E. LOC-area is a directly connected area; a LOC-prefix is

## OSI/DECnet V Monitoring Commands (Talk 5)

a prefix that this router advertises; prefix/I and prefix/E are routes that require another hop to reach their destination.

### Next Hop

Indicates the next hop a packet would take on its route. An \* designation, or a direct designation, refers to a directly-connected host off the router. A system ID refers to the next router the packet must pass through to reach its destination.

## L1-Summary

Use the **I1-summary** command to display a summary of the level 1 link state database.

### Syntax:

#### I1-summary

### Example:

#### **I1-summary**

Link State Database Summary - Level One

LSP ID	Lifetime	Sequence #	Checksum	Flags	Cost
0000-9300-40B0-0000	0	0	0	0	1024
0000-93E0-107A-0000	384	CE	3CC9	1	0
AA00-0400-0504-0000	298	8E	40F1	B	20
AA00-0400-0504-0100	4	B8	A812	3	20

Total Checksum 25CC

### LSP ID

This represents the system ID of the source of the link state PDU plus two additional bytes. The first additional byte designates the type of update. 00 represents a non-pseudonode update. 01–FF represents a pseudonode update for that circuit number. The second byte represents the LSP number. This number is attached to the packet when the data is contained in more than one packet.

### Lifetime

Indicates the amount of time, in seconds, that router will maintain the LSP.

### Sequence #

Indicates the sequence number of the LSP.

### Checksum

Indicates the checksum value of the LSP.

**Flags** Indicates a one-octet value that reflects the flag field of the LSP. The eight bits are broken down as follows:

**Bit 8** Indicates the P flag. When set (1), the issuing IS supports the optional Partition Repair function.

#### Bits 7-4

Indicate the ATT flag. When set (1), the issuing IS is attached to other areas using one of the following: the Default Metric (bit 4), the Delay Metric (bit 5), the Expense Metric (bit 6), or the Error Metric (bit 7).

**Bit 3** Indicates the LSPDBOL flag. When set (1), an LSP database overload has occurred. An LSP with this bit set is not used by the decision process to calculate routes to another I through the originating system.

## OSI/DECnet V Monitoring Commands (Talk 5)

### Bits 2-1

Indicate the IS Type flag. When set to the following values, designates the type of IS router, level 1 or level 2.

#### Value Description

0	Unused.
1	Bit 1 set. Level 1 IS.
2	Unused.
3	Bits 1 and 2 set. Level 2 IS.

**Cost** Indicates the cost of routing to that neighbor.

## L2-Summary

Use the **I2-summary** command to display a summary of the level 2 link state database.

### Syntax:

#### I2-summary

### Example:

#### **I2-summary**

Link State Database Summary - Level Two

LSP ID	Lifetime	Sequence #	Checksum	Flags	Cost
0000-9310-04F0-0000	33E	12	EF19	3	0
0000-5000-FB06-0000	455	4	2BB1	3	20
0000-5000-FB06-0100	469	12	DE32	3	20

Total Checksum 0

The description of the L2-summary output is the same as the I1-summary command.

## L1-Update

Use the **I1-update** command to display a link state update for the specified level 1 IS.

### Syntax:

#### I1-update

### Example:

#### **I1-update**

LSP ID []? 0000931004F0000

Link State Update For ID 0000931004F00000

Area Addresses

470005001

Intermediate System Neighbors	Metric	Two Way
0000931004F002	20	N
0000931004F001	20	Y



## OSI/DECnet V Monitoring Commands (Talk 5)

End System Neighbors	Metric
0000931004F0	*

### LSP ID

Indicates the system ID of the source of the link state PDU plus two additional bytes. The first byte designates the type of update. 00 represents a non-pseudonode update. 01–FF represents a pseudonode update. The second byte represents the LSP number. This number is attached to the packet when the data is contained in more than one packet.

### Area Addresses

Indicates the area addresses in which this router is configured to route packets.

### Intermediate System Neighbors

Indicates adjacent neighbor ISs.

**Metric** Indicates the cost to the neighbor IS.

### Two Way

Indicates whether the router is receiving updates from its neighbor.

### End System Neighbors

Indicates any directly connected ESs.

## L2-Update

Use the `l2-update` command to display the link state update for the specified level 2 IS.

### Syntax:

#### `l2-update`

### Example:

```
l2-update  
LSP ID []? 0000931004F0000
```

Link State Update For ID 0000931004F00000

INTERMEDIATE SYSTEM NEIGHBORS	METRIC	TWO WAY
0000931004F002	20	N
0000931004F001	20	N
55002000182000	20	N

### Intermediate System Neighbors

Indicates other directly connected ISs.

**Metric** Indicates the cost to the IS.

### Two Way

Indicates whether the router is receiving updates from its neighbor.

## Ping-1139

Causes the router to send an echo request to a destination and wait for a reply, as recommended in RFC 1139. RFC 1139 specifies this as an OSI function and not as a DECnet function. **Ping-1139** supports short- and long-term echos. Short-term echos use regular CLNP data packets, which makes them transparent to intermediate systems that do not support RFC1139. Long-term echos use PING request/reply packets.

## OSI/DECnet V Monitoring Commands (Talk 5)

The default data length of the echo request packet is 16 bytes. You can set the data length up to 64 bytes.

Once you enter the **ping-1139** command, echo requests are sent continually until you press any key. At that time, statistics are displayed showing the number of requests transmitted and the number of replies received.

### Syntax:

**ping-1139**

### Example:

```
ping-1139
Long-term/Short-term [LONG-TERM]?
Destination NSAP: []? AA0003000A14
Data Length [16]?

PINGing AA0003000A14

---- PING Statistics ----
 8 requests transmitted, 8 replies received
```

## Route

Use the **route** command to display the next hop a packet would take to a specified destination (destnsap).

### Syntax:

**route** *dest-nsap*

### Example:

```
route 490002aa0004000e08
Destination System: 0000-9310-04C9
Destination MAC Address: AA00-0400-1408
Interface: 0
```

### Destination System

Indicates the system ID of the next hop IS. For a directly connected ES, this will be blank.

### Destination MAC Address

Indicates the MAC address of the next hop IS or the directly-connected ES.

### Interface

Indicates the interface that a packet would go out over to reach the next hop IS or the directly-connected ES.

## Send (Echo Packet)

Use the **send echo packet** command to encode an echo request message in the CLNP packet to the specified destination nsap. During this command, the system does not interact with the OSI monitoring. To verify that the echo request was sent and that an echo reply was received, check the ELS (Event Logging System).

**Note:** You cannot send an echo packet to yourself. If you try, you will receive an CLNP.004 ELS message.

### Syntax:

**send**

**Example:**

```
send
Destination NSAP: []?
```

## Subnets

Use the **subnets** command to display information on all operational subnets. Subnets that are down or disabled will not be listed.

**Syntax:****subnets****Example:**

```
subnets
          L2
Hdw  Int #  Circ  Only  ES-IS  IS-IS  L1DR  L1Pri  L2DR  L2pri  Cost  Ext
PPP/2 2      3    N    N    Y      Y      64    N     64    20   N
Eth/0 0      1    N    Y    Y      Y      64    N     64    20   N
```

**Hdw** The type and instance of the network that connects to the subnet.

**Int #** The router's interface number that connects to the subnet.

**Circ** The circuit assigned ID for the ISIS protocol.

**L2 only**

Whether this router is a level 2 router only, Y (yes) or N (no).

**ES-IS** The ES-IS protocol is enabled on the subnet, Y or N.

**IS-IS** The IS-IS protocol is enabled on the subnet, Y or N.

**L1DR** This router is the level 1 designated router for this subnet, Y or N.

**L1Pri** The subnet's level 1 priority for becoming the designated router.

**L2DR** This router is the level 2 designated router for this subnet, Y or N.

**L2Pri** The LAN subnet's level 2 priority for becoming the designated router.

**Cost** The cost of the circuit.

**Ext** Whether the subnet is operating outside the IS-IS routing domain (external).

## Toggle (Alias/No Alias)

Use the **toggle** alias/no alias command to enable or disable the NSAP alias display function for the OSI protocol.

**Syntax:****toggle****Example:**

```
toggle
Alias substitution is ON
```

## Traceroute

Use the **traceroute** command to track the path an OSI packet takes to a destination.

## OSI/DECnet V Monitoring Commands (Talk 5)

**Note:** You cannot do a traceroute to yourself or you will receive the following error message:

Sorry, can't traceroute to this router.

### Syntax:

**traceroute** *address*

### Example:

```
traceroute 490002aa0004000e08  
Successful trace:
```

```
TRACEROUTE 470007: 56 databytes
```

```
1          490002aa0004000e08      32ms      5ms      5ms
```

```
Destination unreachable response:
```

```
Destination unreachable
```

```
No response:
```

```
1 * * *  
2 * * *
```

### TRACEROUTE

Displays the destination area address and the size of the packet being sent to that address.

- 1 The first trace showing the destination's NSAP and the amount of time it took the packet to arrive at the destination. The packet is traced three times.

### Destination unreachable

Indicates that no route to destination is available.

```
1 * * *
```

- 2 \* \* \* Indicates that the router is expecting some form of response from the destination, but the destination is not responding. The router will wait 32 hops before timing out. Go to the ELS and turn on OSI CLNP messages to determine why the host is not responding.

---

## Chapter 11. Using IP Version 6 (IPv6)

This chapter describes how to use IPv6.

---

### IPv6 Overview

IP Version 6 (IPv6) is a new version of the Internet Protocol. It is designed as a successor to IP Version 4 (IPv4). The following list identifies some of the advantages provided by IPv6:

- Large address space  
IPv6 uses a 128-bit address.
- Routing  
Using the large address size, IPv6 provides an hierarchical address scheme which allows you to create a flexible routing hierarchy.
- Ease of configuration  
NDP provides host autoconfiguration.
- Security  
IPv6 makes IP Security mandatory.
- Support for multimedia traffic  
The IPv6 header has priority and flow label fields to accommodate integrated Quality of Service.
- Simplification  
The IPv6 header is fixed and simplified. The router is no longer required to perform fragmentation, simplifying packet processing. In addition, options type data is implemented in extension headers that are only processed by the destination node.

---

### IPv6 Comparison with IPv4

IPv6 includes many changes from IPv4. The most significant changes are:

- Address
- Header format
- Minimum MTU
- Mandatory Path MTU discovery
- Mandatory IP security
- Neighbor Discovery Protocol (NDP)

---

### IPv6 Addressing

IPv6 addressing increases the address from 32 bits to 128 bits. This increase allows more degrees of hierarchy than the basic layers of network, subnet and host.

IPv6 addresses belong to one of three categories:

- Unicast. A packet is delivered to the interface identified by the address.
- Multicast. A packet is sent to all members of the multicast group identified by the address.
- Anycast. A packet is sent to only the nearest member of the group identified by the address.

## Using IPv6

Broadcast addressing has been replaced by multicast addressing in IPv6.

## IPv6 Address Format

The IPv6 address is composed of 128 bits. These bits are written as eight 16-bit integers separated by colons.

### Example:

**ABCD:1234:0000:1234:5555:FFEE:7777:0123**

You can use the following simplifying rules:

- Skip leading zeroes.

### Example:

**ABCD:1234:0:1234:0:FFEE:7777:123**

- Inside an address, a set of consecutive, null 16-bit numbers can be replaced by two colons.

### Example:

**ABCD:1234::1234:5555:FFEE:7777:123  
1234::7899**

The double colon can be used only once inside the address.

- When dealing with a mixed environment of IPv4 and IPv6 nodes, you can use the form **x:x:x:x:x:d.d.d.d**

, where the x's are hexadecimal values of the six high-order 16-bit pieces of the address, and the d's are the decimal values of the four low-order 8-bit pieces of the address in standard IPv4 representation.

### Example:

**ABCD:1234::1234:5555:FFEE:1.2.3.4  
::1.2.3.4**

## Text Representation of Address Prefixes

An IPv6 address prefix is represented by the notation:

### IPv6-address/prefix-length

The IPv6 address can use any of the notations listed in "IPv6 Address Format" and the prefix length is a decimal value specifying how many of the leftmost contiguous bits of the address comprise the prefix.

### Example:

**ABCD:1234::1234:5555:FFEE:1.2.3.4/64**

---

## IPv6 Header Format

The IPv6 header has a total of 8 fields, eliminating some IPv4 fields such as checksum and fragmentation.

---

## IPv6 Minimum MTU

The minimum MTU for IPv6 is 1280 bytes. You cannot enable IPv6 on an interface with an MTU less than 1280 bytes.

---

## IPv6 Mandatory Path MTU Discovery

Path MTU Discovery is a protocol that allows a host to determine the maximum size packet that will successfully traverse a path to a destination without fragmentation. As packets are generated and sent from the host, the MTU of the particular output interface that the packet will be transmitted to is available.

If the packet will fit on the output interface, either as a whole or in fragments, it is transmitted. If a router in the path needs to forward that packet onto a net with a smaller MTU than the packet size, the packet will be dropped and an ICMP message will be sent to the originator of the packet indicating the packet size that is necessary to fit onto the output net of the intermediate router. The host receiving this message will adjust the size of subsequent packets forwarded on the path. This process may occur multiple times before the packet reaches its final destination. Once the packet reaches its destination, subsequent packets should not be dropped because their packet size being too large.

Because the route can change dynamically, the path MTU may increase and will need adjustment in the host node. Learned path MTUs are aged and the Path MTU Discovery process re-occurs. This allows the transmitted packet size to react to the dynamic nature of routes through the network.

Path MTU Discovery is mandatory because fragmentation is not allowed on transit routers.

If the device is acting as a transit router, it will not forward packets that are larger than the output net's MTU. It will generate an ICMP Packet Too Big message back to the source of the packet.

The **enable path-mtu-discovery** command at the IPv6 Config> prompt can be used to enable or disable path MTU discovery. Path MTU discovery is enabled by default.

Use the **set path-mtu-aging-timer** command at the IPv6 Config> prompt to specify the aging time for path MTUs that have been determined.

---

## IPv6 Mandatory Security

An IPv6 node must support IP security. IP security can be enabled or disabled. See "Using IP Security" and "Configuring and Monitoring IP Security" in the *Using and Configuring Features* for additional information about IP security.

1. Use the **add packet** command at the IPv6 Config> prompt to add a packet filter.
2. Use the **update packet** command at the IPv6 Config> prompt to update the packet filter.
3. Use the **add access** command at the Packet-filter 'filter\_name' Config> prompt to add access controls.

## Using IPv6

4. Use the **set acc on** command at the IPv6 Config> prompt to enable access control.

---

## IPv6 Neighbor Discovery Protocol (NDP)

IPv6 uses NDP to perform autoconfiguration. NDP allows IPv6 nodes on the same link to discover each other's presence, to determine each other's link-layer addresses, to find routers, and to maintain reachability information about the paths to active neighbors.

NDP is supported on the following media types:

- Token Ring
- PPP
- IP64 Tunnel

## Router and Prefix Discovery

Hosts use Router Discovery to discover routers that reside on an attached link. Each router periodically multicasts a Router Advertisement packet, if configured, announcing its availability. Router advertisements contain a list of prefixes used for on-link determination and autonomous address configuration. Hosts can use the advertised on-link prefixes to determine when a packet's destination is on the link or beyond a router.

## Address Autoconfiguration

Router advertisements allow routers to inform host how to perform address autoconfiguration. Routers can specify whether hosts use stateful or autonomous (stateless) address configuration.

## Address Resolution

Routers accomplish address resolution by multicasting a neighbor solicitation message that asks the target node to return its link-layer address. The link-layer address is returned in a unicast neighbor advertisement. By including its link-layer address in the neighbor solicitation message, a single request-response pair of messages, the message initiator and the target can determine each other's link-layer addresses.

## Neighbor Unreachability Detection

NDP can detect the failure of a neighbor or the failure of the forward path to the neighbor. When no positive confirmation has been received from a neighbor for a time interval, the node actively probes the neighbor using unicast neighbor solicitation messages to verify that the forward path is still working.

## Redirect

If the source address of the packet and the next hop are on the same network, a router may send a redirect message informing the sender that the next hop is a neighbor.



Use the **p ndp** command at the Config> prompt to configure NDP parameters.

---

## IPv6 over IPv4 Tunneling

IPv6 over IPv4 tunneling allows you to migrate from IPv4 networks to IPv6 networks without the need to simultaneously upgrade all equipment to IPv6 support. IPv6 over IPv4 tunneling allows IPv6 frames to cross an IPv4 network and reach an IPv6 destination. The IPv6 frame is encapsulated in an IPv4 frame and this encapsulated frame is forwarded through the IPv4 network to a specific IPv4 destination, called the endpoint of the tunnel. At this endpoint, the packet is decapsulated and forwarded to the final IPv6 destination.

Use the **add tunnel** command at the IPv6 Config> prompt to add an IPv6 over IPv4 tunnel.

---

## Protocol Independent Multicast (PIM)

Protocol Independent Multicast (PIM) is a broadcast and prune multicast protocol used by IPv6. It works well in campus networks, where bandwidth is plentiful and users are closely grouped, not dispersed over a wide area of networks. PIM uses a broadcast and prune approach for the multicast forwarding of datagrams and is used when multicast groups are densely distributed across the internet. It assumes that all downstream systems want to receive multicast datagrams and prunes back branches from those systems which do not.

PIM is based on PIM sparse-mode (PIM-SM), which employs the same packet formats. Unlike DVMRP, PIM forwards on all outgoing interfaces until pruning and truncating occurs. This means that PIM does not maintain its own routing tables, as does DVMRP which uses parent-child information to reduce the number of interfaces used before pruning. Once pruning has occurred, the pruning state is maintained and datagrams are only forwarded to downstream members

PIM-DM is a soft state protocol. This means that the prune states, if not removed by some other activity (such as grafting or joining), are removed after a period of time (configurable) and the multicast data is once again broadcast to all downstream systems where pruning once again occurs.

PIM-DM establishes adjacency to neighboring PIM routers by exchanging Hello messages with all neighbors. It keeps the adjacency active until it is timed out. As long as the neighboring routers are active and running, new Hello messages are sent to refresh the Hello state and prevent the adjacency from timing out. How often Hello messages are sent is configurable. Through this mechanism, a designated router is also chosen. For PIM-DM, since it is a broadcast and prune protocol, the designated router has no real function. The designated router is used mainly for PIM-SM operation.

PIM-DM is completely independent of the under-lying unicast protocol. It uses the unicast routing table, regardless which unicast protocol owns an entry, to perform the reverse path forwarding calculation on a received multicast datagram. Reverse path forwarding (rpf) is used to validate whether the received multicast datagram arrived on an interface that would be valid for forwarding to the source address contained in the multicast datagram. If this is an incorrect interface, the datagram is discarded, else a new multicast entry is built and the multicast datagram is forwarded on all other interfaces (those with PIM-DM active, local host members,

## Using IPv6

and any additional interfaces added by other multicast protocols). The use of rpf to validate input interfaces requires unicast routing to be symmetrical.

Grafting is also supported to allow hosts to dynamically join a group. This grafts a branch to an already existing multicast tree, removing all prune states where required to ensure the joined hosts receive the requested group multicast datagrams.

Due to the independent nature of PIM with respect to unicast routing protocols and the broadcast nature of PIM-DM, parallel paths from the source may occur and duplicate multicast data may be forwarded. PIM-DM uses an Assert procedure to choose the appropriate forwarding router when this occurs. Preferences may be configured on routers that run different unicast routing protocols to resolve which router is desired to have precedence. When unicast routing is the same, unicast metric costs to the source is used to determine the best route. And when all else is equal, the router with the largest IP interface address is chosen as the appropriate forwarder.

Use the **p pim** command at the Config> prompt to configure PIM parameters.

---

## Chapter 12. Configuring and Monitoring IPV6

This chapter describes how to use the IPV6 configuration and operating commands and includes the following sections:

- “Accessing the IPV6 Configuration Environment”
- “IPV6 Configuration Commands”
- “Accessing the IPV6 Monitoring Environment” on page 347
- “IPV6 Monitoring Commands” on page 348

---

### Accessing the IPV6 Configuration Environment

Use the following procedure to access the IPV6 configuration process.

1. At the OPCON prompt, enter **talk 6**. (For more detail on this command, refer to *The OPCON Process and Commands* in the Access Integration Services Software User’s Guide.) For example:

```
* talk 6
Config>
```

After you enter the **talk 6** command, the CONFIG prompt (Config>) displays on the terminal. If the prompt does not appear when you first enter configuration, press **Return** again.

2. At the CONFIG prompt, enter the **p ipv6** command to get to the IPV6 Config> prompt.

---

### IPV6 Configuration Commands

To configure IPV6, enter the commands at the IPV6 Config> prompt.

*Table 59. IPV6 Configuration Command Summary*

Command	Function
? (Help)	Displays all the commands available for this command level or lists the options for specific commands (if available). See “Getting Help” on page xxvi.
add	Adds an address, leaked-routes, packet-filter, route, or tunnel.
change	Changes an address, leaked routes, packet-filter, route, or tunnel.
delete	Deletes an address, leaked routes, packet filter, route, or tunnel.
disable	Disables icmp redirects, packet filter, or path MTU discovery.
enable	Enables ICMP redirects, packet filters, or path MTU discovery.
list	Lists the configuration.
set	Sets configuration values associated with automatic tunnels, fast forwarding path cache buffer size, default gateway, MLD, path MTU aging timer, packet reassembly buffer size, routing table size, router id, and router time to live.
update	Updates the packet filter.
Exit	Returns you to the previous command level. See “Exiting a Lower Level Environment” on page xxvi.

### Add

Use the **add** command to add an IPv6 address, leaked routes, packet filters, routes, or IPv6 over IPv4 tunnels.

## IPv6 Configuration Commands (Talk 6)

**add** *address net address prefix*  
*leaked-routes destination*  
*packet-filter name interface*  
*route destination mask gateway cost ...*  
*tunnel destination prefix raddress locaddress cost ttl*  
*fragmentation*

### Example:

```
IPV6 config>add address
Which net is this address for [0]? 5
New address []? 1::2
Prefix length must between 8 and 128 [128]?

IPV6 config>add leaked
IPV4 destination []? 1.2.3.4
Address mask [255.0.0.0]? 255.255.255.255

IPV6 config>add packet-filter
Packet-filter name []? pktf01
Which interface is this filter for [0]? 3

IPV6 config>add route
IPV6 destination []? 8::9
Prefix length must between 8 and 128 [8]? 128
Via gateway 1 at []? 1::2
Cost [1]?
Via gateway 2 at []? 2::3
Cost [1]? 1000
Via gateway 3 at []? 3::4
Cost [1]? 10000
Via gateway 4 at []? 4::5
Cost [1]? 10
IPV6 config>add tunnel
Add a static route through this tunnel? [Yes[:
IPV6 destination network []? 3::4
Prefix length must between 0 and 128 [64]? 128
IPV4 tunnel remote address []? 1.2.3.4
IPV4 tunnel local address []? 2.3.40.0
Cost [1]?
TTL value [64]?
Allow fragmentation in tunnel?(Yes or [No]):
```

### address

Adds an IPv6 address.

#### Which net is this address for

Specifies the net to which the IPv6 address is to be added.

**Valid Values:** A numeric value identifying a network interface

**Default Value:** 0

#### New address

Specifies the new IPv6 address to be added.

**Valid Values:** Any valid IPv6 address

**Default Value:** None

#### Prefix length

Decimal value specifying how many of the leftmost contiguous bits of the address comprise the prefix.

**Valid Values:** 8 - 128

## IPv6 Configuration Commands (Talk 6)

**Default Value:** 128

### **leaked-routes**

Adds a leaked route.

#### **IPv4 destination**

Specifies the IPv6 address of the destination for the leaked route.

**Valid Values:** Any valid IPv6 address

**Default Value:** None

### **packet-filter**

Adds a packet-filter.

#### **packet-filter name**

Specifies an alphanumeric name used to identify the packet filter.

**Valid Values:** Any alphanumeric character string up to 16 characters in length

**Default Value:** None

#### **which interface is this filter for**

Specifies the network interface number to which the packet filter is to be added.

**Valid Values:** A numeric value identifying any interface for which IPv6 is a valid protocol

**Default Value:** 0

**route** Adds a route.

#### **IPv6 destination**

Specifies the IPv6 address of the target for the route.

**Valid Values:** Any valid IPv6 address

**Default Value:** None

#### **Prefix length**

Specifies the mask to be applied to the destination address.

**Valid Values:** 8 - 128 (0 is allowed if the IPv6 destination is 0::0)

**Default Value:** 8

#### **Via gateway 1**

Specifies the IPv6 address of the gateway 1.

**Valid Values:** Any valid IPv6 address

**Default Value:** None

**Cost** Specifies the cost of this route.

**Valid Values:** A numeric value

**Default Value:** 1

#### **Via gateway 2**

Specifies the IPv6 address of the gateway 2.

**Valid Values:** Any valid IPv6 address

**Default Value:** None

**Cost** Specifies the cost of this route.

## IPv6 Configuration Commands (Talk 6)

**Valid Values:** A numeric value

**Default Value:** 1

### Via gateway 3

Specifies the IPv6 address of the gateway 3.

**Valid Values:** Any valid IPv6 address

**Default Value:** None

**Cost** Specifies the cost of this route.

**Valid Values:** A numeric value

**Default Value:** 1

### Via gateway 4

Specifies the IPv6 address of the gateway 4.

**Valid Values:** Any valid IPv6 address

**Default Value:** None

**Cost** Specifies the cost of this route.

**Valid Values:** A numeric value

**Default Value:** 1

**tunnel** Adds a tunnel.

### Add a static route through this tunnel?

Specifies whether or not the tunnel will have a static route defined.

**Valid Values:** Yes or No

**Default Value:** Yes

### IPv6 destination network

Specifies the IPv6 address of the destination network that will be reached by the tunnel.

**Valid Values:** Any valid IPv6 address

**Default Value:** None

### Prefix length

Decimal value specifying how many of the leftmost contiguous bits of the IPv6 address comprise the prefix.

**Valid Values:** 8 - 128

**Default Value:** 64

### IPv4 tunnel remote address

Specifies the IPv4 address for the IPv6 frames passed through the tunnel.

**Valid Values:** Any valid IP (32-bit) address

**Default Value:** None

### IPv4 tunnel local address

Specifies the IPv4 source address for the IPv6 frames passed through the tunnel.

**Valid Values:** Any valid IP (32-bit) address

**Default Value:** None

## IPv6 Configuration Commands (Talk 6)

**Cost** Specifies the cost associated with the tunnel which will be used during route lookups to find the best route to the destination.

**Valid Values:** 1 - 255

**Default Value:** 1

### TTL value

Specifies the time-to-live value used in frames encapsulated for this tunnel

**Valid Values:** Any numeric value in the range of 1 - 255

**Default Value:** 64

### Allow fragmentation in the tunnel?

Specifies whether the fragmentation in the tunnel will be allowed. Specifying *yes* allows fragmentation in the tunnel in case the IPv4 network that the tunnel is using does not provide enough information to allow the device to return a “Packet Too Big” message to the IPv6 host.

**Valid Values:** yes or no

**Default Value:** no

## Change

Use the **change** command to add an IPv6 address, leaked routes, packet filters, routes, or tunnels.

### Syntax:

```
change address net address prefix  
leaked-routes destination  
packet-filter name interface  
route destination mask gateway cost ...  
tunnel destination prefix raddress locaddress cost ttl  
fragmentation
```

### address

Changes an address.

### leaked-routes

Changes a leaked route configuration.

### packet-filter

Changes a packet filter configuration.

**route** Changes a route configuration.

**tunnel** Changes a tunnel configuration.

See “Add” on page 333 for a description of the parameters associated with the **change** command.

## Delete

Use the **delete** command to remove an address, leaked-routes, packet filter, route or tunnel.

## IPv6 Configuration Commands (Talk 6)

### Syntax:

delete *address address*  
*leaked-routes destination*  
*packet-filter name*  
*route destination mask gateway*  
*tunnel tunnel#*

## Disable

Use the **disable** command to disable ICMP redirect, packet filters, and path MTU discovery.

### Syntax:

disable *icmp-redirect address*  
*packet-filter packet-filter-name*  
*path-mtu-discovery*

#### **icmp-redirect**

Disables ICMP redirects.

#### **packet-filter**

Disables a packet-filter.

#### **packet-filter name**

Specifies the name of the packet filter to be disabled.

**Valid Values:** Any configured packet filter

**Default Value:** None

#### **path-mtu-discovery**

Disables Path MTU Discovery.

## Enable

Use the **enable** command to enable ICMP redirects, packet filters, or path MTU discovery.

### Syntax:

enable *icmp-redirect address*  
*packet-filter packet-filter-name*  
*path-mtu-discovery*

#### **icmp-redirect**

Enables ICMP redirects.

#### **interface address**

Specifies the interface address.

**Valid Values:** Any valid IPv6 address

**Default Value:** Null (specifies all addresses)

#### **packet-filter**

Enables a packet-filter.



## IPv6 Configuration Commands (Talk 6)

### packet-filter name

Specifies the name of the packet-filter to be enabled. This name is configured using the **add packet-filter** command.

**Valid Values:** Any valid IPv6 address

**Default Value:** None

### path-mtu-discovery

Enables Path MTU Discovery, a protocol that allows a host node to determine the maximum size packet that will traverse a path to a destination without fragmentation.

## List

Use the **list** command to display the IPv6 configuration.

### Syntax:

```
list                all
                    addresses
                    icmp-redirect
                    leaked-routes
                    mld
                    packet-filter
                    routes
                    sizes
                    tunnels
```

### Example:

```
IPv6 config>list all
Interface addresses
IPv6 addresses for each interface:
  intf 0                IP disabled on this interface
  intf 1                IP disabled on this interface
  intf 2                IP disabled on this interface
  intf 3                IP disabled on this interface
  intf 4                IP disabled on this interface
  intf 5    1234:1234:1234:1234:5234:6234:7234:8234/128
                1223::7:1234/8
Router-ID: 1::9
Internal IP address: 1::8

Routing

route to: 1234::1223/128
  via: 1234:0:9::8                cost: 100
  via: 1234:0:9:8:8:7:6:8         cost: 232
  via: 1:2:3:4:5:6:7:8           cost: 1
  via: 8:7:6:5:4:3:2:1           cost: 1
route to: ::/0
  via: 1::8                       cost: 100
route to: 2::8/9/8
  via: 1::8                       cost: 1

Path MTU Discovery:  disabled
```

## IPv6 Configuration Commands (Talk 6)

Path MTU Aging Timer: 10 minutes

IPv6 config>**list addresses**

IPv6 addresses for each interface:

```
intf 0 IP disabled on this interface
intf 1 IP disabled on this interface
intf 2 IP disabled on this interface
intf 3 IP disabled on this interface
intf 4 IP disabled on this interface
intf 5 1234:1234:1234:1234:5234:6234:7234:8234/128
      1223::7:1234/8
```

Router-ID: 1::9

Internal IP address: 1::8

IPv6 config>**list icmp-redirect**

ICMP Redirect generation for IP interface:

```
intf 0 IP disabled on this interface
intf 1 IP disabled on this interface
intf 2 IP disabled on this interface
intf 3 IP disabled on this interface
intf 4 IP disabled on this interface
intf 5 1234:1234:1234:1234:5234:6234:7234:8234/128 ICMP Redirect enabled
      1223::7:1234/8 ICMP Redirect enabled
intf 6 IP disabled on this interface
intf 7 IP disabled on this interface
```

IPv6 config>**list leaked-routes**

# IPv4 Address Mask

IPv6 config>**list mld**

Net	Query Interval (secs)	Response Interval (secs)	Leave Query Interval (secs)
---	-----	-----	-----
5	125	10	1

IPv6 config>**list packet-filter**

List of packet-filter records:

Name	Interface	State
packet01	0	On
pack01	5	On

Access Control is: enabled

IPv6 config>**list routes**

```
route to: 1234::1223/128
  via: 1234:0:9::8 cost: 100
  via: 1234:0:9:8:8:7:6:8 cost: 232
  via: 1:2:3:4:5:6:7:8 cost: 1
  via: 8:7:6:5:4:3:2:1 cost: 1
route to: ::/0
  via: 1::8 cost: 100
route to: 2::8:9/8
  via: 1::8 cost: 1
```

IPv6 config>**list sizes**

Routing table size: 768 nets (79872 bytes)  
Reassembly buffer size: 12000 bytes  
Routing cache size: 64 entries  
Time to live: 64  
Path MTU aging timer: 10

## IPv6 Configuration Commands (Talk 6)

```
IPv6 config>list tunnel
Tun# Remote Endpoint Local Endpoint Frag Allowed TTL Cost Net# IPv6 Address/Prefix
1 1.2.3.4 2.3.4.5 No 100 100 7 1:2:3:4:5:6:7:8/128
IPv6 config>
```

## Set

Use the **set** command to set configuration parameters.

### Syntax:

```
set
    access-control
    automatic-tunnel-parameters tll fragmentation
    hopcount
    cache-size #entries
    default ...
    internal-ip-address
    mld ...
    path-mtu-aging-timer
    reassembly-size
    router-id
    routing #nets
    tll
```

### Example:

```
IPv6 config>set au
TTL value [64]?
Allow fragmentation in tunnel?(Yes or [No]):
```

```
IPv6 config>set ca
number of cache entries [64]?
```

```
IPv6 config>set mld query-interval
Network interface [0]? 5
New Query Interval (in secs) [125]?
```

```
IPv6 config>set mld response-interval
Network interface [0]? 5
New Response Interval (in secs) [10]?
```

```
IPv6 config>set mld robust
Network interface [0]? 5
New Robustness Variable [2]?
IPv6 config>set mld leave
Network interface [0]?
New Leave Interval (in secs) [1]?
IPv6 config>
```

### access-control

Specifies whether access control is enabled or disabled.

**Valid Values:** on or off

**Default Value:** off

## IPv6 Configuration Commands (Talk 6)

### **automatic-tunnel-parameters**

Specifies the tunnel parameter values for automatic tunnels that flow through the router.

#### **ttl value**

Specifies the time-to-live value for the frames encapsulated for the tunnel.

**Valid Values:**

**Default Value:** 64

#### **allow fragmentation in tunnel?**

Specifies whether the fragmentation in the tunnel will be allowed. Specifying *yes* allows fragmentation in the tunnel in case the IPv4 network that the tunnel is using does not provide enough information to allow the device to return a "Packet Too Big" message to the IPv6 host.

**Valid Values:** yes or no

**Default Value:** no

#### **hop count**

Specifies the hop count to be used on automatically tunnelled packets.

**Valid Values:** 1 - 255

**Default Value:** 64

### **cache-size**

Specifies the buffer size for the fast forwarding path cache.

#### **number of cache entries**

Specifies the number of entries in the fast forwarding path cache.

**Valid Values:** 64 - 10 000

**Default Value:** 64

### **default network-gateway**

#### **default gateway**

**Valid Values:** Any valid IPv6 address

**Default Value:** none

#### **gateway's cost**

Specifies the cost associated with this gateway.

**Valid Values:** 1 - 255

**Default Value:** 1

### **default subnet-gateway**

#### **for which subnetted network**

**Valid Values:** Any valid IPv6 address

**Default Value:** none

#### **default gateway**

**Valid Values:** Any valid IPv6 address

**Default Value:** none

## IPv6 Configuration Commands (Talk 6)

### gateway's cost

Specifies the cost associated with this gateway.

**Valid Values:** 1 - 255

**Default Value:** 1

### internal-ip-address

**Valid Values:** Any valid IPv6 address

**Default Value:** None

### mld

#### query-interval

##### network interface

**Valid Values:** Any valid network interface number

**Default Value:** 0

##### new query interval (in secs)

**Valid Values:** 1 - 3600

**Default Value:** 125

#### response-interval

##### network interface

**Valid Values:** Any valid network interface number

**Default Value:** 0

##### new response interval (in secs)

**Valid Values:** 1 - 60

**Default Value:** 10

#### robustness-variable

##### network interface

**Valid Values:** Any valid network interface number

**Default Value:** 0

##### new robustness variable

**Valid Values:** 2 - 10

**Default Value:** 2

#### leave-interval

##### network interface

**Valid Values:** Any valid network interface number

**Default Value:** 0

##### new leave interval (in secs)

**Valid Values:** 1 - 60

**Default Value:** 1

## IPv6 Configuration Commands (Talk 6)

### path-mtu-aging-timer

Specifies the aging time in minutes for path MTUs that have been determined using path MTU discovery.

**Valid Values:** 10 - 60 minutes, where 0 = disable

**Default Value:** 10

### reassembly-size

Specifies the size of the reassembly buffers used for processing the fragment header.

**Valid Values:** 2048 - 65536

**Default Value:** 12000

### router-id

Specifies the IPv6 address of the router.

**Valid Values:** Any valid IPv6 address

**Default Value:** None

### routing table-size

#### number of nets

**Valid Values:** 64 - 65 535

**Default Value:** 768

**tll** Specifies the IPv6 time-to-live value.

**Valid Values:**

**Default Value:** 64

## Update

Use the **update** command to update the packet filter

### Syntax:

**update** packet-filter

### packet-filter

Use this command to access the Packet-filter 'xx' Config> command prompt from which you can configure packet-filters.

## Update Packet-filter Commands

Table 60. Update Packet-filter Configuration Command Summary

Command	Function
? (Help)	Displays all the commands available for this command level or lists the options for specific commands (if available). See "Getting Help" on page xxvi.
Add	Adds access control.
Change	Changes access control.
Delete	Deletes access control.
Move	Reorders the access control list applied to the packet filter.
List	
Exit	Returns you to the previous command level. See "Exiting a Lower Level Environment" on page xxvi.

### Add

Use the **update packet-filter add** command to add an access control list.

#### Syntax:

```
add access-control type sourceaddr sourceprefix  
destaddr destprefix
```

#### **access-control**

Adds an access-control item to the access control list.

**Type** Specifies whether the access control is inclusive or used to identify packets to be secured.

**Valid Values:** I or S

**Default Value:** I

#### **Internet source**

Specifies the IPv6 address of the packet source.

**Valid Values:** Any valid IPv6 address

**Default Value:** None

#### **Prefix length**

Decimal value specifying how many of the leftmost contiguous bits of the IPv6 address comprise the prefix.

**Valid Values:** 0- 128

**Default Value:** 128

#### **Internet destination**

Specifies the IPv6 address of the packet destination.

**Valid Values:** Any valid IPv6 address

**Default Value:** None

#### **Prefix length**

Decimal value specifying how many of the leftmost contiguous bits of the IPv6 address comprise the prefix.

**Valid Values:** 0- 128

**Default Value:** 128

### Change

Use the **update packet-filter change** command to change access control.

#### Syntax:

```
change access-control type sourceaddr sourceprefix  
destaddr destprefix
```

#### **access-control**

Changes an access-control item.

**Type** Specifies whether the access control item is inclusive or used to identify packets to be secured..

**Valid Values:** I or S

**Default Value:** I

## IPv6 Configuration Commands (Talk 6)

### Internet source

Specifies the IPv6 address of the packet source.

**Valid Values:** Any valid IPv6 address

**Default Value:** None

### Prefix length

Decimal value specifying how many of the leftmost contiguous bits of the IPv6 address comprise the prefix.

**Valid Values:** 0- 128

**Default Value:** 128

### Internet destination

Specifies the IPv6 address of the packet destination.

**Valid Values:** Any valid IPv6 address

**Default Value:** None

### Prefix length

Decimal value specifying how many of the leftmost contiguous bits of the IPv6 address comprise the prefix.

**Valid Values:** 0- 128

**Default Value:** 128

## Delete

Use the **update packet-filter delete** command to remove an access control item from the access control list.

### Syntax:

**delete** *access-control index#*

#### **access-control**

Deletes access-control.

#### **index of access control to be deleted**

Specifies the index of the access control configuration to be removed.

**Valid Values:** 1 to the number of access control records defined for this packet filter

**Default Value:** 1

## Move

Use the **update packet-filter move** command to re-order the access control list applied to the packet-filter.

### Syntax:

**move** *access-control index# after#*

#### **access-control**

#### **index of control to move**

**Valid Values:** 1 to the number of access control records defined for this packet filter





## IPV6 Monitoring Commands

This section describes the IPV6 monitoring commands.

Table 61. IPv6 Monitoring Command Summary

Command	Function
? (Help)	Displays all the commands available for this command level or lists the options for specific commands (if available). See “Getting Help” on page xxvi.
cache	Displays cache entries.
counters	Display counters
dump routing tables	Dumps the configured routing tables.
interface addresses	Displays the addresses defined on the interface.
mcast	Displays a list of registered multicast addresses.
mld	Displays MLD counters or parameters.
route sizes	Displays buffer sizes.
static routes	Displays static routes.
packet-filter	Displays configured packet filters.
path-mtu	
ping6	Activates Ping.
traceroute6	Dynamically traces a route.
tunnels	Displays configured tunnels.
Exit	Returns you to the previous command level. See “Exiting a Lower Level Environment” on page xxvi.

### Cache

Use the **cache** command to display

**Syntax:**

cache

**Example:**

```
IPV6>cache
Destination                               Usage           Next hop
```

### Counters

Use the **counters** command to display the status of counters.

**Syntax:**

counters

**Example:**

```
IPV6>counters
Routing errors
Count  Type
0      Routing table overflow
0      Net unreachable
0      Bad subnet number
0      Bad net number
```

```

0 Unhandled broadcast
0 Unhandled anycast
0 Unhandled directed broadcast
0 Attempted forward of LL broadcast
0
0 None

Packets discarded through filter 0
IP multicasts accepted:          0

IP input packet overflows
  Net  Count
TKR/0  0
TKR/1  0
FR/0   0
PPP/0  0
IP64/0 0

```

### Dump routing tables

Use the **dump** command to display the configured routing tables.

#### Syntax:

**dump**

#### Example:

```

IPV6>dump
Type  Dest net/Prefix          Cost    Age    Next hop(s)

Stat* 1:2:3:4:5:6:7:8/128          100 30    IP64/0

IPV6 Routing table size: 768 nets (79872 bytes), 1 nets known
                        0 nets hidden, 0 nets deleted, 0 nets inactive
                        0 routes used internally, 767 routes free

```

### Interface addresses

Use the **interface** command to display addresses configured on the interface.

#### Syntax:

**interface**

#### Example:

```

IPV6>interface
Interface IPv6 Address/Prefix len
PPP/0     1223::7:1234/8
          1234:1234:1234:1234:5234:6234:7234:8234/128
IP64/0    FE80::486F:65FF:FE69:7/64

```

### Mcast

Use the **mcast** command to display configured multicast addresses.

#### Syntax:

**mcast**

## IPv6 Monitoring Commands (Talk 5)

### Example:

```
IPV6>mcast
List of IPV6 registered multicast addresses
```

```
Interface: TKR/0:
Interface: TKR/1:
Interface: FR/0:
Interface: PPP/0:
Interface: IP64/0:
IPV6>
```

## Mld

Use the **mld** command to display configured.

### Syntax:

```
mld                counters
                    parameters
```

### Example:

```
IPV6>mld counters
Net      Querier      Polls Sent      Polls Rcvd      Reports Rcvd
---      -
IPV6>mld parameters
Net      Robustness      Query Interval      Response Interval      Leave Query Interval
      Variable      (secs)      (secs)      (secs)
---      -
IPV6>
```

## Route

Use the **route** command to show the route to the IPv6 address.

### Syntax:

```
route                address
```

### Example:

```
IPV6>route 6::9
IPV6>
```

## Sizes

Use the **sizes** command to display configured buffer sizes.

### Syntax:

```
sizes
```

### Example:

```
IPV6>sizes
Routing table size:          768
Table entries used:         3
Reassembly buffer size:    12000
Largest reassembled pkt:   0
Size of routing cache:     64
# cache entries in use:    0
```

IPV6>

## Static routes

Use the **static** command to display configured static routes.

### Syntax:

**static**

### Example:

```
IPV6>static
Net/Mask_len      Cost  Next hop
1234::1223/128    100   1234:0:9::8 PPP/0
                  232   1234:0:9:8:8:7:6:8 PPP/0
8::9              128  N/A   filter
```

IPV6>

## Packet-filter

Use the **packet-filter** command to display a summary of configured packet filters.

### Syntax:

**packet-filter**

### Example:

```
IPV6>pac
Name      Dir  Intf  State  #Access-Controls
packet01  Out  0     On     0
pack01    Out  5     On     2
IPV6>
```

## Path-mtu

Use the **path-mtu** command to show the paths that have been identified as having an MTU that is less than the size of a packet sent along that path.

### Syntax:

**path-mtu**

### Example:

## Ping6

Use the **ping6** command to ping an IPv6 address.

### Syntax:

## IPv6 Monitoring Commands (Talk 5)

### ping6

#### **Example:**

```
IPV6>ping
Destination IPv6 address [::]? 8::9
Source IPv6 Address [1::8]?
Ping data size in bytes [56]?
Ping TTL [64]?
Ping rate in seconds [1]?
PING6 1::8 -> 8::9: 56 data bytes, ttl=64, every 1 sec.

----8::9 PING6 Statistics----
36 packets transmitted, 36 packets received
```

#### **Destination IPv6 address**

**Valid Values:** Any valid IPv6 address

**Default Value:** None

#### **Source IPv6 address**

**Valid Values:** Any valid IPv6 address

**Default Value:** None

#### **Ping data size in bytes**

**Valid Values:** 0 to size of global buffer

**Default Value:** 56

#### **Ping ttl**

Specifies the time-to-live for the ping.

**Valid Values:** 1 - 255

**Default Value:** 64

#### **Ping rate in seconds**

Specifies the ping frequency.

**Valid Values:** 1 - 60

**Default Value:** 1

## Traceroute6

Use the **traceroute6** command to dynamically trace a route.

#### **Syntax:**

**traceroute6 ...**

#### **Example:**

```
IPV6>traceroute6
Destination IPv6 address []? 7::8
Source IPv6 address []? 6::9
Data size in bytes [56]?
Number of probes per hop [3]?
Wait time between retries in seconds [3]?
Maximum TTL [32]?
TRACEROUTE6 7::8: 56 data bytes
 1 * * * *
IPV6>
```

#### **Destination IPv6 address**

## IPv6 Monitoring Commands (Talk 5)

**Valid Values:** Any valid IPv6 address

**Default Value:** None

### Source IPv6 address

**Valid Values:** Any valid IPv6 address

**Default Value:** None

### Data size in bytes

**Valid Values:** 0 to size of global buffer

**Default Value:** 56

### Number of probes per hop

**Valid Values:** 1 - 10

**Default Value:** 3

### Wait time between retries in seconds

**Valid Values:** 1 - 60

**Default Value:** 3

### Maximum ttl

**Valid Values:** 1 - 255

**Default Value:** 32

## Tunnels

Use the **tunnels** command to display configured tunnels.

### Syntax:

**tunnels**

### Example:

```
IPV6>tunnels
```

```
                Configured Tunnels
Tun#  Remote Endpoint  Local Endpoint  Frag Allowed  TTL  MTU  Net#  IPv6 Address/Prefix
  1    1.2.3.4            2.3.4.5        No            100  2048  7     1:2:3:4:5:6:7:8/128
```

```
                Automatic Tunnels
Tun#  Remote Endpoint  Frag Allowed  TTL  MTU
IPV6>
```

## IPV6 Monitoring Commands (Talk 5)



---

## Chapter 13. Configuring and Monitoring Neighbor Discovery Protocol (NDP)

Configuration for NDP is done for each interface. This chapter describes how to use the NDP configuration and operating commands and includes the following sections:

- “Accessing the NDP Configuration Environment”
- “NDP Configuration Commands”
- “Accessing the NDP Monitoring Environment” on page 359
- “NDP Monitoring Commands” on page 360

---

### Accessing the NDP Configuration Environment

Use the following procedure to access the NDP configuration process.

1. At the OPCON prompt, enter **talk 6**. (For more detail on this command, refer to *The OPCON Process and Commands* in the Access Integration Services Software User’s Guide.) For example:

```
* talk 6
Config>
```

After you enter the **talk 6** command, the CONFIG prompt (Config>) displays on the terminal. If the prompt does not appear when you first enter configuration, press **Return** again.

2. At the CONFIG prompt, enter the **p ndp** command to get to the NDP6 Config> prompt.

---

### NDP Configuration Commands

To configure NDP, enter the commands at the NDP6 Config> prompt.

*Table 62. NDP Configuration Command Summary*

Command	Function
? (Help)	Displays all the commands available for this command level or lists the options for specific commands (if available). See “Getting Help” on page xxvi.
add	Adds a router advertisement or parameters.
change	Changes a router advertisement or parameters.
delete	Deletes a router advertisement or parameters.
disable	Disables router advertisement.
enable	Enables router advertisement.
list	Lists the configuration.
Exit	Returns you to the previous command level. See “Exiting a Lower Level Environment” on page xxvi.

#### Add

Use the **add** command to add a router advertisement.

```
add                                ra ...
```

## NDP Configuration Commands (Talk 6)

### Example:

```
NDP config>add ra
```

**ra** Adds a router advertisement.

#### **add router advertisement on which interface**

Specifies the interface to which the router advertisement is to be added.

**Valid Values:** A numeric value identifying a network interface

**Default Value:** 0

#### **Managed address configuration (stateful)**

Specifies whether hosts use the administered protocol for address autoconfiguration in addition to addresses autoconfigured using stateless autoconfiguration.

**Valid Values:** yes or no

**Default Value:** n

#### **Other stateful configuration**

Specifies whether hosts use the administered protocol for autoconfiguration of other (non-address) information.

**Valid Values:** yes or no

**Default Value:** no

#### **Include link layer address with router advertisement**

Specifies whether to include the link layer address in the router advertisement. A router may omit the link layer address in the router advertisement in order to enable inbound load sharing across multiple link layer addresses.

**Valid Values:** yes or no

**Default Value:** yes

#### **Hop limit**

Specifies the default value to be placed in the hop limit field in the router advertisement messages sent by the router. This value is used in the hop count field of the IP header for outgoing IP packets.

**Valid Values:** 0 - 255, where 0 means unspecified by this router

**Default Value:** 0

#### **Maximum router advertisement interval**

Specifies the maximum time, in seconds, allowed between sending unsolicited multicast router advertisements from the interface.

**Valid Values:** 4 - 1800 seconds

**Default Value:** 600

#### **Minimum router advertisement interval**

Specifies the minimum time, in seconds, allowed between sending unsolicited multicast router advertisements from the interface.

**Valid Values:** 3 - (.75 \* *Maximum router advertisement interval*)

**Default Value:** *Maximum router advertisement interval*/3

## NDP Configuration Commands (Talk 6)

### Router lifetime

Specifies the time, in seconds, that the router is to be used as a default router.

**Valid Values:** 0 or 4 - 9000 seconds, where 0 indicates that the router is not being used as a default router

**Default Value:** (3 \* *Maximum router advertisement interval*)

### Reachable Time

Specifies the time, in seconds, that a node assumes a neighbor is reachable after having received a reachability confirmation.

**Valid Values:** 0 - 3 600 seconds, where 0 indicates unspecified by this router

**Default Value:** 0

### Retransmit timer

Specifies the time, in seconds, between retransmitted neighbor solicitation messages.

**Valid Values:** 0 - 3 600 seconds, where 0 indicates unspecified by this router

**Default Value:** 0

### link-mtu

Specifies the value to be placed in the MTU options sent by the router. This value should be sent on links that have a variable MTU and may be sent on other links.

**Valid Values:** A 32-bit unsigned integer, where 0 indicates that no MTU options are sent

**Default Value:** 0

## Change

Use the **change** command to change a route advertisement or prefix.

### Syntax:

```
change                ra ...  
                        prefix ...
```

**ra** Changes a configured route advertisement. See “Add” on page 355 for a description of the parameters associated with the **change ra** command.

**prefix** Changes a configured prefix. Prefixes are added or deleted as you modify the IPV6 address configuration. See “Add” on page 333 for more information about adding IPv6 addresses.

To add a prefix:

```
Config> p ipv6  
IPV6 user configuration  
IPV6 config> add addr  
Which net is this address for [0]? 5  
New address []? 2002:9::6204  
Prefix length must be between 8 and 128 [128]? 64  
IPV6 config> exit
```

To change a prefix:

## NDP Configuration Commands (Talk 6)

```
Config> p ndp6
Neighbor Discovery for IPv6 user configuration
NDP6 Config> change prefix
Change Prefix Information option for which Prefix address []? 2002:2::
Use this prefix for on-link determination? [Yes]:
Use this prefix for autonomous address configuration? [Yes]: n
Valid lifetime for Prefix [2592000]? ffffffff
Preferred Lifetime for Prefix [604800]? ffffffff
```

### Change prefix information options for which prefix address?

Specifies the IPv6 address prefix to be placed in the prefix information option in router advertisements sent from the interface.

**Valid Values:** Any valid IPv6 address

**Default Value:** None

### Use this prefix for on-link determination?

Specifies the value to be placed in the on-link flag in the prefix information option. When set to *yes*, the prefix can be used for on-link determination. When set to *no*, the advertisement will make no statement about on-link or off-link properties of the prefix.

**Valid Values:** yes or no

**Default Value:** yes

### Use this prefix for autonomous address configuration?

Specifies the value to be placed in the autonomous address configuration flag in the prefix information option. When set to *yes*, the prefix can be used for autonomous address configuration.

**Valid Values:** yes or no

**Default Value:** yes

### valid lifetime for prefix

Specifies the amount of time, in seconds, to be placed in the valid lifetime in the prefix information option. This value represents the length of time, relative to the time that the packet is sent, that the prefix is valid for the purpose of on-link determination.

**Valid Values:** A 32-bit unsigned integer, where X'FFFFFFFF' represents unlimited lifetime

**Default Value:** 259200 (which is 30 days)

### Preferred lifetime for prefix

Specifies the amount of time, in seconds, to be placed in the preferred lifetime in the prefix information option. This value represents the length of time, relative to the time that the packet is sent, that addresses generated from the prefix via stateless address autoconfiguration remain preferred.

**Valid Values:** A 32-bit unsigned integer, where X'FFFFFFFF' represents unlimited lifetime

**Default Value:** 604800

## Delete

Use the **delete** command to remove a configured route advertisement.

**Syntax:**

```
delete                ra
```

## Disable

Use the **disable** command to disable route advertisement.

### Syntax:

```
disable                ra  
ra    Disables route advertisement.
```

## Enable

Use the **enable** command to enable route advertisement.

### Syntax:

```
enable                ra  
ra    Enables route advertisement.
```

## List

Use the **list** command to display the NDP configuration.

### Syntax:

```
list                    all  
                        ra  
                        prefix
```

### Example:

```
NDP config>list all
```

```
NDP config>list ra
```

```
NDP config>list prefix  
NDP config>
```

---

## Accessing the NDP Monitoring Environment

Use the following procedure to access the NDP monitoring commands. This process gives you access to the NDP monitoring process.

1. At the OPCON prompt, enter **talk 5**. (For more detail on this command, refer to “The OPCON Process” in *Access Integration Services Software User’s Guide*.)  
For example:

```
* talk 5  
+
```

After you enter the **talk 5** command, the GWCON prompt (+) displays on the terminal. If the prompt does not appear when you first enter configuration, press **Return** again.

2. At the + prompt, enter the **p ndp** command to get you to the NDP> prompt.

### Example:

## NDP Configuration Commands (Talk 6)

```
+ p ndp
NDP>
```

---

## NDP Monitoring Commands

This section describes the NDP monitoring commands.

*Table 63. NDP Monitoring Command Summary*

Command	Function
? (Help)	Displays all the commands available for this command level or lists the options for specific commands (if available). See “Getting Help” on page xxvi.
dump	Displays routing tables.
ping6	Dynamically pings an IPv6 address.
list	Displays the configuration.
Exit	Returns you to the previous command level. See “Exiting a Lower Level Environment” on page xxvi.

### Dump

See “Dump routing tables” on page 366 for information about the **dump** command.

### Ping6

See “Ping6” on page 351 for details about the **ping6** command.

### List

Use the **list** command to display the configuration. Only interfaces with RA configured are displayed even though a prefix may exist in the prefix list on other interfaces as a result of IPv6 address configuration.

#### Syntax:

**list**

#### Example:

```
NDP>list all
```

```
Router Advertisement for Interface 0 (PPP/0):
```

State	M	O	LLA	Limit	Hop	RA Interval	Rtr	Reach	Retrans	MTU
					Min - Max	Lifetime	Time	Timer		
ENABLED	N	N	Y	0	200 - 600	1800	0	0	0	0

```
Advertised Prefixes:
```

```
Prefix/Length
```

```
On-Link Auto Valid/Preferred Life
```

---

## Chapter 14. Configuring and Monitoring Protocol Independent Multicast Routing Protocol (PIM)

Configuration for PIM is done for each interface. This chapter describes how to use the PIM configuration and operating commands and includes the following sections:

- “Accessing the PIM Configuration Environment”
- “PIM Configuration Commands”
- “Accessing the PIM Monitoring Environment” on page 365
- “PIM Monitoring Commands” on page 366

---

### Accessing the PIM Configuration Environment

Use the following procedure to access the PIM configuration process.

1. At the OPCON prompt, enter **talk 6**. (For more detail on this command, refer to “The OPCON Process” in *Access Integration Services Software User’s Guide*.)  
For example:

```
* talk 6
Config>
```

After you enter the **talk 6** command, the CONFIG prompt (Config>) displays on the terminal. If the prompt does not appear when you first enter configuration, press **Return** again.

2. At the CONFIG prompt, enter the **p pim** command to get to the PIM6 Config> prompt.

---

### PIM Configuration Commands

To configure PIM, enter the commands at the PIM6 Config> prompt.

*Table 64. PIM Configuration Command Summary*

Command	Function
? (Help)	Displays all the commands available for this command level or lists the options for specific commands (if available). See “Getting Help” on page xxvi.
delete	Deletes a PIM interface.
disable	Disables PIM on the device.
enable	Enables PIM on the device and sets global PIM default configuration values.
list	Lists the configuration.
set	Sets PIM configuration parameter values.
Exit	Returns you to the previous command level. See “Exiting a Lower Level Environment” on page xxvi.

#### Delete

Use the **delete** command to remove a configured PIM interface.

##### Syntax:

```
delete interfaceaddr
```

**Interface address**

## PIM Configuration Commands (Talk 6)

### Example:

```
PIM6 Config> delete  
Interface address []?
```

## Disable

Use the **disable** command to disable PIM on the device.

### Syntax:

disable

## Enable

Use the **enable** command to enable PIM on the device and set global PIM default configuration values.

### Syntax:

enable

## List

Use the **list** command to display the PIM configuration.

### Syntax:

```
list                all  
                    interface  
                    preference  
                    variables
```

**all** Displays all PIM configuration information.

### interface

Displays PIM configuration information about the currently configured interfaces.

### Example:

```
PIM config>list i
```

Type	IP Address	Hello Interval	State Holdtime
Physical	1:2:3:4:5::101	30	210

**Type** Identifies the type of interface that is configured.

### IP address

Identifies the IPv6 address assigned to this interface.

### Hello Interval

Identifies the interval between hello messages, in seconds, sent on this interface.

### State holdtime

Identifies the number of seconds to tell other devices upstream to hold PIM state for this device. For PIM, this is the amount of time for upstream devices to keep prunes alive.



## PIM Configuration Commands (Talk 6)

### variables

Displays configuration information about global PIM variables.

#### Example:

```
PIM config>list v
      PIM Global Configuration Values
      PIM: on
      Graft Timeout:      3 seconds
      Assert Timeout:    210 seconds
PIM config>
```

#### PIM: on/off

Identifies whether PIM is currently enabled or disabled.

#### Graft timeout

Identifies the number of seconds that grafts are retransmitted if no graft acknowledgement has been received.

#### Assert timeout

Identifies the number of seconds that assert information learned by upstream devices is retained before reverting back to local routing information.

### preference

Displays current configured routing type metric preferences.

#### Example:

```
PIM config>list p
      RIP      FFFF      Default  FFFF
      Direct   FFFF      Fixed    FFFF
      Filter   FFFF
PIM config>
```

#### Route type

Identifies the route type supported and lists a hexadecimal value displaying the currently configured metric preference.

## Set

Use the **set** command to change PIM configuration parameter values. You can use this command to add a new physical interface.

#### Syntax:

```
set                interface interfaceaddress helloperiod
                    joinpruneholdtime
                    preference routetype preferencevalue
                    variables
```

### interface

#### Example:

```
PIM config>set interface
Interface address []?
Hello period [30]?
Join Prune Hold Time [210]?
```

#### Interface address

**Valid Values:** Any valid IPv6 address

## PIM Configuration Commands (Talk 6)

**Default Value:** None

### Hello period

Specifies the number of seconds between Hello messages. On point-to-point interfaces, this value is ignored. Once the 2212 establishes adjacency, Hello messages are silenced.

**Valid Values:** 1 - 65535

**Default Value:** 30

### Join prune hold time

Controls messages to inform the receiving device on how long (in seconds) to hold the state activated by the message. Prunes sent to the device remain active for this number of seconds.

**Valid Values:** 1 - 65535

**Default Value:** 210

### preference routetype

This is a configured metric preference to be used in the assert process. It allows the user to selectively select which unicast route types in the unicast forwarding tables has precedence over other route types. It is of local significance only, meaning it is used for this device and all its attached PIM activated interfaces. This can be used if several unicast routing protocols are in use by this router, adjacent routers are running different routing protocols, or route types, such as default routes, are desired over learned routes.

**Routetype** can specify the following route types:

- rip
- direct
- fixed
- default
- filter

### Example:

```
PIM Config> set preference rip
RIP Metric Preference (hex) [FFFF]?
```

### Metric Preference

This value is sent to other routers in the assert process during duplicate multicast forwarding detection and is used with route metric costs to determine which router should be the forwarding router. All metric preferences are initially set to X'FFFF'.

**Valid Values:** A 4-digit hexadecimal value

**Default Value:** X'FFFF'

### variables cache\_life

### Example:

```
PIM config>set v cache_life
Mcfwd cache Holdtime [60]
```

### Mcfwd cache holdtime

Specifies the amount of time in seconds that a multicast forwarding entry which has not been used to forward any multicast datagrams will be allowed to exist in the multicast forwarding cache before it is removed.

## PIM Configuration Commands (Talk 6)

**Valid Values:** A numeric value greater than 0

**Default Value:** 60

### variables assert\_tout

**Example:**

```
PIM config>set v assert_tout
PIM Assert Time Out [210]
```

**Assert time out**

The amount of time in seconds that downstream routers will save assert information received from two or more asserting upstream routers. Assert information is used to ensure the downstream routers understand who the correct upstream router is, or forwarding router, so that PIM messages may be sent to the correct router. If no further asserts are received before the assert time has expired, the assert information is discarded and the router uses local information in the unicast routing tables to determine the correct upstream forwarding router.

**Valid Values:** 1 - 65535

**Default Value:** 210

### variables graft\_tout

**Example:**

```
PIM config>set v graft_tout
PIM Graft Time Out [3]
```

**Graft time out**

Specifies the number of seconds that the device that has sent a graft message, but has received no acknowledgement, will wait before sending another message.

**Valid Values:** 1 - 65535

**Default Value:** 3

---

## Accessing the PIM Monitoring Environment

Use the following procedure to access the PIM monitoring commands. This process gives you access to the PIM monitoring process.

1. At the OPCODE prompt, enter **talk 5**. (For more detail on this command, refer to *The OPCODE Process and Commands* in the Access Integration Services Software User's Guide.) For example:

```
* talk 5
+
```

After you enter the **talk 5** command, the GWCON prompt (+) displays on the terminal. If the prompt does not appear when you first enter configuration, press **Return** again.

2. At the + prompt, enter the **p pim** command to get you to the PIM6> prompt.

**Example:**

```
+ p pim
PIM6>
```

# PIM Monitoring Commands

This section describes the PIM monitoring commands.

Table 65. PIM Monitoring Command Summary

Command	Function
? (Help)	Displays all the commands available for this command level or lists the options for specific commands (if available). See “Getting Help” on page xxvi.
dump	Displays routing tables.
clear	Clears the multicast forwarding table.
interface	Displays the status of the interface.
join	Joins a multicast group.
leave	Leaves a multicast group.
mcache	Displays currently active multicast forwarding table cache entries.
mgroups	Displays group membership of the device’s attached interfaces.
mstats	Displays various multicast routing statistics.
neighbor	Displays information about current adjacencies.
pim	Displays the PIM state database.
summary pim	Displays a summary of the PIM state database.
ping	Dynamically pings an IPv6 address.
traceroute	Dynamically traces a route.
variables	Displays the configuration values for PIM variables.
Exit	Returns you to the previous command level. See “Exiting a Lower Level Environment” on page xxvi.

## Dump routing tables

Use the **dump** command to display the configured routing tables.

### Syntax:

**dump**

### Example:

```
PIM6>dump
Type  Dest net/Prefix          Cost   Age   Next hop(s)
Fltr  ::102:304/128            0      576   filter
Stat* 1:2:3:4:5:6:7:8/128     100    576   IP64/0
Stat* 3::4/128                1      576   IP64/1

IPv6 Routing table size: 768 nets (79872 bytes), 3 nets known
                        0 nets hidden, 0 nets deleted, 0 nets inactive
                        0 routes used internally, 765 routes free

PIM6>
```

## Clear

Use the **clear** command to reset the cache.

### Syntax:

**clear**

### Example:

```
PIM6>clear
Mfwd Cache has been cleared!
PIM6>
```

## Interface

Use the **interface** command to display a summary of the statistics and parameters related to the interface.

### Syntax:

**interface**

### Example:

```
PIM6>interface
PIM Interface Table
```

IP Address	Hello Interval	State Holdtime	Status	Type
1:2:3:4:5:6::101	30	210	up	TKR/0
1:2:5:6:7::102	30	210	up	TKR/1

```
PIM6>
```

### IP address

Specifies the IP address of the interface.

### Hello interval

Specifies the number of seconds between hello messages on this interface.

### State holdtime

Specifies the number of seconds upstream devices are informed to hold state information before discarding. For PIM, this is the number of seconds a prune is active upstream.

### Status

Specifies the current status of the interface.

**up** The interface is up and fully operational, but does not generate the mld queries.

### disabled

The interface is operational but is disabled and PIM is not active.

**down** The interface is not operational.

## Join

Use the **join** command to join a multicast group.

### Syntax:

**join**

### Example:

```
PIM6>join ff05:42::101
```

## PIM Monitoring Commands (Talk 5)

### Leave

Use the **leave** command to leave a multicast group. This prevents the device from responding to pings and SNMP queries sent to the group address.

#### Syntax:

**leave**

#### Example:

```
PIM6>leave ff05:42::101
```

### Mcache

Use the **mcache** command to display a list of currently active multicast cache entries. Multicast cache entries are built on demand, whenever the first matching multicast datagram is received. There is a separate cache entry (and therefore a separate route) for each datagram source network and destination group combination.

#### Syntax:

**mcache**

#### Example:

```
PIM6>mcache
```

0: TKR/0	1: TKR/1	2: TKR/2			
3: IPPN/0	4: BDG/0	5: Internal			
			Prot	Count	Upstr Downstream
0:1:2::					
FF05:42::101			PIM6	8	0 1,2
3:4:22::					
FF05:42::102			PIM6	8	1 0
3:12:2::					
FF05:33:4::120			PIM6	25	0 2

```
PIM6>
```

**Prot** Specifies the owning protocol of the multicast forwarding table entry.

**Count** Displays the number of multicast packets received for this multicast forwarding table entry.

**Upstr** Displays the neighboring network or router from which the datagram must be received in order to be forwarded.

#### Downstream

Displays the total number of downstream interfaces or neighbors to which the datagram will be forwarded.

### Mgroup

Use the **mgroup** command to display the group membership of the device's attached interfaces. Only the group membership for those interfaces on which the router is either designated router or backup designated router are displayed.

**Syntax:**

**mgroup**

**Example:**

PIM6>**mgroup**

Group	Local Group Database	Interface	Lifetime (secs)
FF05:42::101		1:2:3:4::25 (TRK/0)	176
FF05:4:23::122		23:2:113::45:23 (Eth/1)	170
FF05:4:23::122		Internal	1

PIM6>

**Group** Displays the group address as it has been reported (via MLD) on a particular interface.

**Interface**

Displays the interface address to which the group address has been reported (via MLD). The router's internal group membership is indicated by a value of *internal*. For these entries, the lifetime field (see below) indicates the number of applications that have requested membership in the particular group.

**Lifetime**

Displays the number of seconds that the entry will persist if Membership Reports cease to be heard on the interface for the given group.

## Mstats

Use the **mstats** command to display various multicast routing statistics. The command indicates whether multicast routing is enabled and whether the router is an inter-area and/or inter-AS multicast forwarder.

**Syntax:**

**mstats**

**Example:**

PIM6>**mstats**

Datagrams received:	2496		
Datagrams fwd (multicast):	0	Datagrams fwd (unicast):	0
Locally delivered:	0		
Unreachable source:	3	Unallocated cache entries:	0
Off multicast tree:	0	Unexpected DL multicast:	0
Buffer alloc failure:	0	TTL scoping:	0
# fwd cache alloc:	1	# fwd cache freed:	0
#fwd cache GC:	0	# local group DB alloc:	0
#local group DB free:	1		

PIM6>

**Datagrams received**

Displays the number of multicast datagrams received by the router.

**Datagrams fwd (multicast)**

Displays the number of datagrams that have been forwarded as data-link multicasts (this includes packet replications, when necessary, so this count could very well be greater than the number received).

## PIM Monitoring Commands (Talk 5)

### **Datagrams fwd (unicast)**

Displays the number of datagrams that have been forwarded as data-link unicasts.

### **Locally delivered**

Displays the number of datagrams that have been forwarded to internal applications.

### **Unreachable source**

Displays a count of those datagrams whose source address was unreachable.

### **Unallocated cache entries**

Displays a count of those datagrams whose cache entries could not be created due to resource shortages.

### **Off multicast tree**

Displays a count of those datagrams that were not forwarded either because there was no upstream neighbor or no downstream interfaces/neighbors in the matching cache entry.

### **Unexpected DL multicast**

Displays a count of those datagrams that were received as data-link multicasts on those interfaces that have been configured for data-link unicast.

### **Buffer alloc failure**

Displays a count of those datagrams that could not be replicated because of buffer shortages.

### **TTL scoping**

Indicates those datagrams that were not forwarded because their TTL indicated that they could never reach a group member.

### **#fwd cache alloc**

Indicates the number of cache entries allocated. The current forwarding cache size is the number of entries allocated (**# fwd cache alloc**) minus the number of cache entries freed (**# fwd cache freed**).

### **#fwd cache freed**

Indicates the number of cache entries freed. The current forwarding cache size is the number of entries allocated (**# fwd cache alloc**) minus the number of cache entries freed (**# fwd cache freed**).

### **#fwd cache GC**

Indicates the number of cache entries were cleared because they were not recently used and the cache overflowed.

### **#local group DB alloc**

Indicates the number of local group database entries allocated. The number allocated (**# local group DB alloc**) minus the number freed (**# local group DB free**) equals the current size of the local group database.

### **#local group DB free**

Indicates the number of local group database entries freed. The number allocated (**# local group DB alloc**) minus the number freed (**# local group DB free**) equals the current size of the local group database.

## Neighbor

Use the **neighbor** command to display information about neighbor PIM devices and their adjacency status.



**Syntax:**

**neighbors**

**Example:**

```
PIM6>neighbors
PIM Neighbor Listing
```

Neighbor Addr	DR	Last Heard	First Heard	Ifc
9:4:3:101:2::123	NO	21	6139	Tkr/0
23:2:45:2::12:3:111	YES	29	6204	Tkr/1

```
PIM6>
```

**Neighbor Addr**

Identifies if this router has identified the neighbor as the designated router.

**DR** Identifies if this router has identified the neighbor as the designated router.

**Last Heard**

The number of seconds since last heard from the neighbor.

**First Heard**

The total number of seconds since the adjacency was first established to this neighbor.

**Ifc** The interface that the neighbor was discovered on.

## PIM

Use the **pim** command to display the PIM state database.

**Syntax:**

**pim**

**Example:**

```
PIM6>pim
PIM State Database
-----
1) Group: FF05:2:3::121
1) Source: 9:1:2:3::12:101
1) Interface: 1 - PRUNE Lifetime (sec): 210

2) Group: FF05:2:3::121
2) Source: 9:1:2:3::12:101
2) Interface: 1 - PRUNE Lifetime (sec): 210
PIM6>
```

**Group** The destination group address associated with the entry.

**Source**

The source address of the originator of the multicast datagram.

**Interface**

The PIM interface number and the type of PIM state in the database.

**Lifetime**

The total lifetime, in seconds, of the state received, obtained from the PIM control message that set up the state.

## PIM Monitoring Commands (Talk 5)

### Summary PIM

Use the **summary pim** command to display summary information about the PIM state database.

**Syntax:**

**summary pim**

**Example:**

```
PIM6>s
```

```
                Summary PIM State Database
                -----
0)    Group: FF05:2:3::121
0)    Source: 9:1:2:3::12:101
0)    States: 1-P 2-P
```

```
PIM6>
```

**Group** The destination group address associated with the entry.

**Source**

The source address of the originator of the multicast datagram.

**States** Displays the interfaces and states associated to the source group pair. P identifies a prune state.

### Ping

Use the **ping** command to dynamically ping another destination IPv6 address.

**Syntax:**

**ping**

**Example:**

```
PIM6>ping
Destination IPv6 address [::]? 8::9
Source IPv6 Address [1::8]?
Ping data size in bytes [56]?
Ping TTL [64]?
Ping rate in seconds [1]?
PING6 1::8 -> 8::9: 56 data bytes, ttl=64, every 1 sec.
```

```
----8::9 PING6 Statistics----
36 packets transmitted, 36 packets received
```

See “Ping6” on page 351 for a description of the parameters.

### Traceroute

Use the **traceroute** command to dynamically trace a route.

**Syntax:**

**traceroute**

**Example:**

```

IPV6>traceroute
Destination IPv6 address []? 7::8
Source IPv6 address []? 6::9
Data size in bytes [56]?
Number of probes per hop [3]?
Wait time between retries in seconds [3]?
Maximum TTL [32]?
TRACEROUTE6 7::8: 56 data bytes
 1 * * * *
IPV6>

```

See “Traceroute6” on page 352 for a description of the parameters.

## Variables

Use the **variables** command to display information about the PIM configuration variables.

### Syntax:

**variables**

\_

### Example:

```

PIM6>v

PIM: on

      Graft Timeout:      3 seconds
      Assert Timeout:    210 seconds

PIM Unicast Metric Preferences (hex)
RIP      FFFF      Default  FFFF
Direct   FFFF      Fixed    FFFF
Filter   FFFF
PIM6>

```

### PIM: on/off

This indicates whether PIM-DM is currently enabled or disabled.

### Graft Timeout

The number of seconds that grafts are retransmitted if no graft acknowledgement has been received.

### Assert Timeout

The number of seconds that assert information learned by upstream routers is retained before reverting back to local routing information.

### PIM Unicast Metric Preferences

Displays current configured routing type metric preferences. Each route type supported is listed with a hex value displaying the currently configured metric preference.

## PIM Monitoring Commands (Talk 5)

---

## Chapter 15. Configuring and Monitoring Routing Information Protocol (RIP6)

RIP6 is a distance vector routing protocol. Configuration for RIP6 is done for each interface. This chapter describes how to use the RIP6 configuration and operating commands and includes the following sections:

- “Accessing the RIP6 Configuration Environment”
- “RIP6 Configuration Commands”
- “Accessing the RIP6 Monitoring Environment” on page 381
- “RIP6 Monitoring Commands” on page 381

---

### Accessing the RIP6 Configuration Environment

Use the following procedure to access the RIP6 configuration process.

1. At the OPCON prompt, enter **talk 6**. (For more detail on this command, refer to “The OPCON Process” in *Access Integration Services Software User’s Guide*.)  
For example:

```
* talk 6
Config>
```

After you enter the **talk 6** command, the CONFIG prompt (Config>) displays on the terminal. If the prompt does not appear when you first enter configuration, press **Return** again.

2. At the CONFIG prompt, enter the **p rip6** command to get to the RIP66 Config> prompt.

---

### RIP6 Configuration Commands

To configure RIP6, enter the commands at the RIP66 Config> prompt.

*Table 66. RIP6 Configuration Command Summary*

Command	Function
? (Help)	Displays all the commands available for this command level or lists the options for specific commands (if available). See “Getting Help” on page xxvi.
add	Adds RIP6 on an interface.
change	Changes RIP6 metric configuration values.
delete	Removes RIP6 from an interface.
disable	Disables RIP6 on an interface.
enable	Enables RIP6 on an interface.
list	Lists the configuration.
set	Sets RIP6 metric values.
Exit	Returns you to the previous command level. See “Exiting a Lower Level Environment” on page xxvi.

#### Add

Use the **add** command to add RIP6 on an interface.

#### Syntax:

## RIP6 Configuration Commands (Talk 6)

add *interface#*

### **interface#**

Specifies the interface to which RIP6 protocol is to be added.

**Note:** This interface must have an IPV6 address configured or be the virtual interface of an IPV6 over IPV4 tunnel.

**Valid Values:** Any valid interface number

**Default Value:** None

## Change

Use the **change** command to change a RIP6 metric.

### **Syntax:**

change rip6-in-metric  
rip6-out-metric

### **rip6-in-metric**

Changes the value of the RIP6 metric for the incoming RIP6 updates.

#### **Change RIPng metric on which interface?**

Specifies the interface number on which RIP6 input metric is to be changed.

**Note:** The interface must have RIP6 configured.

**Valid Values:** Any valid interface number

**Default Value:** 0

#### **RIP6 input Metric**

Changes the value of the RIP6 metric on incoming RIP6 updates.

**Valid Values:** 1 - 15

**Default Value:** 1

### **rip6-out-metric**

Changes the RIP6 metric on the outgoing RIP6 updates.

#### **Change RIPng metric on which interface?**

Specifies the interface number on which RIP6 output metric is to be changed.

**Note:** The interface must have RIP6 configured.

**Valid Values:** Any valid interface number

**Default Value:** 0

#### **RIP6 output Metric**

Specifies the value of the RIP6 metric on outgoing RIP6 updates.

**Valid Values:** 0 - 15

**Default Value:** 0

## Delete

Use the **delete** command to remove RIP6 from the specified interface.

### Syntax:

**delete** *interface#*

### **interface#**

Specifies the interface from which RIP6 protocol is to be removed.

**Note:** The interface must have RIP6 configured.

**Valid Values:** Any valid interface number

**Default Value:** None

## Disable

Use the **disable** command to disable RIP6.

### Syntax:

**disable** *rip6*  
*override ...*  
*sending ...*

**rip6** Disables RIP6 on the specified interface.

**Valid Values:** Yes or No

**Default Value:** Yes

### **Modify RIP6 flags on which interface?**

Specifies the interface number on which RIP6 is to be disabled.

**Note:** The interface must have RIP6 configured.

**Valid Values:** Any valid interface number

**Default Value:** 0

### **override ...**

#### **static-routes**

Overrides RIP6 static routes on an interface.

#### **Modify RIP6 flags on which interface?**

Specifies the interface number on which RIP6 is to be disabled.

**Note:** The interface must have RIP6 configured.

**Valid Values:** Any valid interface number

**Default Value:** 0

#### **default**

Overrides RIP6 default routes on an interface.

## RIP6 Configuration Commands (Talk 6)

### Modify RIP6 flags on which interface?

Specifies the interface number on which RIP6 is to be disabled.

**Note:** The interface must have RIP6 configured.

**Valid Values:** Any valid interface number

**Default Value:** 0

sending ...

### Modify RIP6 flags on which interface?

Specifies the interface number on which RIP6 is to be disabled.

**Note:** The interface must have RIP6 configured.

**Valid Values:** Any valid interface number

**Default Value:** 0

### all-routes

Disables advertisement of all RIP6 routes on an interface.

**Valid Values:** Yes or No

**Default Value:** Yes

### default-routes

Disables advertisement of RIP6 default routes on an interface.

**Valid Values:** Yes or No

**Default Value:** Yes

### static-routes

Disables advertisement of RIP6 static routes on an interface.

**Valid Values:** Yes or No

**Default Value:** Yes

### poisoned-reverse-routes

Disables poison reverse in sending RIP6 updates on an interface.

**Valid Values:** Yes or No

**Default Value:** Yes

## Enable

Use the **enable** command to enable RIP6.

### Syntax:

```
enable                _rip6
                        _override ...
                        _sending ...
```

**rip6** Enables RIP6 on the specified interface.

**Valid Values:** Yes or No

**Default Value:** Yes



## RIP6 Configuration Commands (Talk 6)

### Modify RIP6 flags on which interface?

Specifies the interface number on which RIP6 is to be enabled.

**Note:** The interface must have RIP6 configured.

**Valid Values:** Any valid interface number

**Default Value:** 0

### override ...

#### static-routes

Overrides RIP6 static routes on an interface.

### Modify RIP6 flags on which interface?

Specifies the interface number on which RIP6 is to be enabled.

**Note:** The interface must have RIP6 configured.

**Valid Values:** Any valid interface number

**Default Value:** 0

#### default

Overrides RIP6 default routes on an interface.

### Modify RIP6 flags on which interface?

Specifies the interface number on which RIP6 is to be enabled.

**Note:** The interface must have RIP6 configured.

**Valid Values:** Any valid interface number

**Default Value:** 0

### sending ...

### Modify RIP6 flags on which interface?

Specifies the interface number on which RIP6 is to be enabled.

**Note:** The interface must have RIP6 configured.

**Valid Values:** Any valid interface number

**Default Value:** 0

#### all-routes

Enables advertisement of all RIP6 routes on an interface.

**Valid Values:** Yes or No

**Default Value:** Yes

#### default-routes

Enables advertisement of RIP6 default routes on an interface.

**Valid Values:** Yes or No

**Default Value:** Yes

## RIP6 Configuration Commands (Talk 6)

### **static-routes**

Enables advertisement of RIP6 static routes on an interface.

**Valid Values:** Yes or No

**Default Value:** Yes

### **poisoned-reverse-routes**

Enables poison reverse in sending RIP6 updates on an interface.

**Valid Values:** Yes or No

**Default Value:** Yes

## List

Use the **list** command to display the RIP6 configuration.

### **Syntax:**

**list** all

### **Example:**

```
RIP6 config>list all
```

## Set

Use the **set** command to set RIP6 configuration parameters.

### **Syntax:**

**set** rip6-in-metric  
rip6-out-metric

### **rip6-in-metric**

Sets the RIP6 metric on incoming RIP6 updates.

#### **Change RIPng metric on which interface?**

Specifies the interface number on which RIP6 input metric is to be set.

**Valid Values:** Any valid interface number

**Default Value:** 0

#### **RIP6 input Metric**

Specifies the value of the RIP6 metric used on incoming RIP6 updates.

**Valid Values:** 1 - 15

**Default Value:** 1

### **rip6-out-metric**

Sets the RIP6 metric used on outgoing RIP6 updates.

#### **Change RIPng metric on which interface?**

Specifies the interface number on which RIP6 output metric is to be set.

**Valid Values:** Any valid interface number

**Default Value:** 0

**RIP6 output Metric**

Specifies the value of the metric used on outgoing RIP6 updates.

**Valid Values:** 0 - 15

**Default Value:** 0

---

## Accessing the RIP6 Monitoring Environment

Use the following procedure to access the RIP6 monitoring commands. This process gives you access to the RIP6 monitoring process.

1. At the OPCON prompt, enter **talk 5**. (For more detail on this command, refer to “The OPCON Process” in *Access Integration Services Software User’s Guide*.)  
For example:

```
* talk 5
+
```

After you enter the **talk 5** command, the GWCON prompt (+) displays on the terminal. If the prompt does not appear when you first enter configuration, press **Return** again.

2. At the + prompt, enter the **p rip6** command to get you to the RIP6> prompt.

**Example:**

```
+ p rip6
RIP6>
```

---

## RIP6 Monitoring Commands

This section describes the RIP6 monitoring commands.

*Table 67. RIP6 Monitoring Command Summary*

Command	Function
? (Help)	Displays all the commands available for this command level or lists the options for specific commands (if available). See “Getting Help” on page xxvi.
list	Displays the configuration.
dump	Displays routing tables.
ping6	Dynamically pings an IPv6 address.
Exit	Returns you to the previous command level. See “Exiting a Lower Level Environment” on page xxvi.

### List

Use the **list** command to display the configuration.

**Syntax:**

**list**

**Example:**

```
RIP6>list
```

### Dump

See “Dump routing tables” on page 366 for information about the **dump** command.

## RIP6 Monitoring Commands (Talk 5)

### Ping6

See “Ping6” on page 351 for details about the **ping6** command

---

## Appendix. Packet Sizes

This appendix discusses the sizes of packets for the various networks and protocols supported. Included are the following sections:

- General Issues
- Network-Specific Size Limits
- Protocol-Specific Size Limits
- Changing Maximum Packet Sizes

---

### General Issues

For the purposes of this discussion, the packets that the routers handle consist of user data and header information.

The amount of user data within a packet is limited by the amount of header information on the packet. The amount of header information depends on (at least):

- The network-types over which the packet must travel.
- The protocols in use on these networks.

The following factors affect the size of the packet contents:

- Length of the Data-Link header information that the current network type and interface require the packet to have.
- Length of the trailer information (if any) that the current network type and interface require the packet to have.

On any given network, the sum of the maximum data size together with header and trailer sizes will equal the network's maximum packet size. When routing between networks of different maximum packet size, fragmentation of the packet may result.

---

### Network-Specific Size Limits

Given the information in the previous section, the maximum amount of network layer data supported by each data link layer (network interface) can be determined. Table 68 lists the default maximum packet sizes for common interface types.

*Table 68. Default Network-Specific Maximum Packet Size*

<b>Network Type (Data Link)</b>	<b>Network Layer max packet size (bytes)</b>	<b>Length of Network Header</b>	<b>Information Trailer</b>
Token-Ring 4 Mbps	2052	22	0
Token-Ring 16 Mbps	2052	22	0
Ethernet	1500	18	4
PPP	2046	2	0
Frame Relay	2048*	variable	2

|  
|  
|  
|  
|  
|

\*: For Frame Relay interfaces, you configure the maximum frame size not the network layer maximum packet size. To determine the maximum network layer packet size for a protocol, see the description of the **set frame-size** command in the chapter entitled Configuring and Monitoring Frame Relay Interfaces in *Access Integration Services Software User's Guide* .

## Packet Sizes

**Note:** You can change the maximum packet size for interfaces other than Ethernet. Use the **network** command from the Config> prompt to access the interface's configuration commands.

The maximum packet size is the maximum amount of data the protocol forwarder can pass to the device.

**Note:** These numbers correspond to the MTUs in 4.2 BSD UNIX.

For an IP packet, this includes the IP header, the UDP or TCP header, and all data.

The packet size in use is displayed when the router's GWCON memory command is used. The "Pkt" size is the Network layer packet size. The Hdr (header) and Tr (trailer) sizes depend on the networks and their network interfaces.

---

## Protocol-Specific Size Limits

This section explains the protocol-specific size limits.

### IP Packet Lengths

The IP protocol specifications do not require a host IP implementation to accept IP packets of more than 576 octets; however, router IP implementations must accommodate IP packets of any length up to the limits imposed by the network-specific packets in use.

Furthermore, router IP performs transparent fragmentation and reassembly of packets that would otherwise exceed network-specific length restrictions, as required by the IP specification.

Packet size mismatches do not cause connectivity problems. However, fragment reassembly does pose a performance penalty, so fragmentation should be avoided whenever possible.

---

## Changing Maximum Packet Sizes

Normally, the router automatically sets the maximum network layer packet size to the size of the largest possible packet on all the connected networks. It then adds any headers and trailers required by the networks to determine the internal buffer size, which is larger than the network layer size.

Some networks (Token-Ring 4 Mbps and Token-Ring 16 Mbps) allow you to configure maximum packet sizes. Configuring maximum packet sizes affects the size of buffers used on the router and this in turn affects the number of buffers available for a given memory size. Routers automatically determine what size buffer it is going to need. You can change the maximum Network layer packet size that the router handles by using the set packet-size command; however, do not use this command unless specifically directed to by Customer Service.

---

## List of Abbreviations

<b>AARP</b>	AppleTalk Address Resolution Protocol
<b>ABR</b>	area border router
<b>ack</b>	acknowledgment
<b>AIX</b>	Advanced Interactive Executive
<b>AMA</b>	arbitrary MAC addressing
<b>AMP</b>	active monitor present
<b>ANSI</b>	American National Standards Institute
<b>AP2</b>	AppleTalk Phase 2
<b>APPN</b>	Advanced Peer-to-Peer Networking
<b>ARE</b>	all-routes explorer
<b>ARI/FCI</b>	address recognized indicator/frame copied indicator
<b>ARP</b>	Address Resolution Protocol
<b>AS</b>	autonomous system
<b>ASBR</b>	autonomous system boundary router
<b>ASCII</b>	American National Standard Code for Information Interchange
<b>ASN.1</b>	abstract syntax notation 1
<b>ASRT</b>	adaptive source routing transparent
<b>ASYNC</b>	asynchronous
<b>ATCP</b>	AppleTalk Control Protocol
<b>ATP</b>	AppleTalk Transaction Protocol
<b>AUI</b>	attachment unit interface
<b>ayt</b>	are you there
<b>BAN</b>	Boundary Access Node
<b>BBCM</b>	Bridging Broadcast Manager
<b>BECN</b>	backward explicit congestion notification
<b>BGP</b>	Border Gateway Protocol
<b>BNC</b>	bayonet Niell-Concelman
<b>BNCP</b>	Bridging Network Control Protocol
<b>BOOTP</b>	BOOT protocol
<b>BPDU</b>	bridge protocol data unit
<b>bps</b>	bits per second
<b>BR</b>	bridging/routing
<b>BRS</b>	bandwidth reservation
<b>BSD</b>	Berkeley software distribution

**BTP** BOOTP relay agent  
**BTU** basic transmission unit  
**CAM** content-addressable memory  
**CCITT** Consultative Committee on International Telegraph and Telephone  
**CD** collision detection  
**CGWCON**  
Gateway Console  
**CIDR** Classless Inter-Domain Routing  
**CIP** Classical IP  
**CIR** committed information rate  
**CLNP** Connectionless-Mode Network Protocol  
**CPU** central processing unit  
**CRC** cyclic redundancy check  
**CRS** configuration report server  
**CTS** clear to send  
**CUD** call user data  
**DAF** destination address filtering  
**DB** database  
**DBsum**  
database summary  
**DCD** data channel received line signal detector  
**DCE** data circuit-terminating equipment  
**DCS** Directly connected server  
**DDLC** dual data-link controller  
**DDN** Defense Data Network  
**DDP** Datagram Delivery Protocol  
**DDT** Dynamic Debugging Tool  
**DHCP** Dynamic Host Configuration Protocol  
**dir** directly connected  
**DL** data link  
**DLC** data link control  
**DLCI** data link connection identifier  
**DLS** data link switching  
**DLSw** data link switching  
**DMA** direct memory access  
**DNA** Digital Network Architecture  
**DNCP** DECnet Protocol Control Protocol  
**DNIC** Data Network Identifier Code



**DoD** Department of Defense  
**DOS** Disk Operating System  
**DR** designated router  
**DRAM** Dynamic Random Access Memory  
**DSAP** destination service access point  
**DSE** data switching equipment  
**DSE** data switching exchange  
**DSR** data set ready  
**DSU** data service unit  
**DTE** data terminal equipment  
**DTR** data terminal ready  
**Dtype** destination type  
**DVMRP**  
     Distance Vector Multicast Routing Protocol  
**E1** 2.048 Mbps transmission rate  
**EDEL** end delimiter  
**EDI** error detected indicator  
**EGP** Exterior Gateway Protocol  
**EIA** Electronics Industries Association  
**ELAN** Emulated LAN  
**ELAP** EtherTalk Link Access Protocol  
**ELS** Event Logging System  
**ELSCon**  
     Secondary ELS Console  
**ESI** End system identifier  
**EST** Eastern Standard Time  
**Eth** Ethernet  
**fa-ga** functional address-group address  
**FCS** frame check sequence  
**FECN** forward explicit congestion notification  
**FIFO** first in, first out  
**FLT** filter library  
**FR** Frame Relay  
**FRL** Frame Relay  
**FTP** File Transfer Protocol  
**GMT** Greenwich Mean Time  
**GOSIP**  
     Government Open Systems Interconnection Profile

**GTE** General Telephone Company

**GWCON** Gateway Console

**HDLC** high-level data link control

**HEX** hexadecimal

**HPR** high-performance routing

**HST** TCP/IP host services

**HTF** host table format

**IBD** Integrated Boot Device

**ICMP** Internet Control Message Protocol

**ICP** Internet Control Protocol

**ID** identification

**IDP** Initial Domain Part

**IDP** Internet Datagram Protocol

**IEEE** Institute of Electrical and Electronics Engineers

**ifc#** interface number

**IGP** interior gateway protocol

**InARP** Inverse Address Resolution Protocol

**IP** Internet Protocol

**IPCP** IP Control Protocol

**IPPN** IP Protocol Network

**IPX** Internetwork Packet Exchange

**IPXCP** IPX Control Protocol

**ISDN** integrated services digital network

**ISO** International Organization for Standardization

**Kbps** kilobits per second

**LAN** local area network

**LAPB** link access protocol-balanced

**LAT** local area transport

**LCS** LAN Channel Station

**LCP** Link Control Protocol

**LED** light-emitting diode

**LF** largest frame; line feed

**LIS** Logical IP subnet

**LLC** logical link control

**LLC2** logical link control 2

**LMI** local management interface

**LRM** LAN reporting mechanism

**LS** link state  
**LSA** link state advertisement  
**LSA** Link Services Architecture  
**LSB** least significant bit  
**LSI** LAN shortcuts interface  
**LSreq** link state request  
**LSrxl** link state retransmission list  
**LU** logical unit  
**MAC** medium access control  
**Mb** megabit  
**MB** megabyte  
**Mbps** megabits per second  
**MBps** megabytes per second  
**MC** multicast  
**MCF** MAC filtering  
**MIB** Management Information Base  
**MIB II** Management Information Base II  
**MILNET**  
     military network  
**MOS** Micro Operating System  
**MOSDBG**  
     Micro Operating System Debugging Tool  
**MOSPF**  
     Open Shortest Path First with multicast extensions  
**MPC** Multi-Path Channel  
**MPC+** High performance data transfer (HPDT) Multi-Path Channel  
**MSB** most significant bit  
**MSDU** MAC service data unit  
**MRU** maximum receive unit  
**MTU** maximum transmission unit  
**nak** not acknowledged  
**NAS** Nways Switch Administration station  
**NBMA** Non-Broadcast Multiple Access  
**NBP** Name Binding Protocol  
**NBR** neighbor  
**NCP** Network Control Protocol  
**NCP** Network Core Protocol  
**NDPS** non-disruptive path switching

**NetBIOS** Network Basic Input/Output System

**NHRP** Next Hop Resolution Protocol

**NIST** National Institute of Standards and Technology

**NPDU** Network Protocol Data Unit

**NRZ** non-return-to-zero

**NRZI** non-return-to-zero inverted

**NSAP** Network Service Access Point

**NSF** National Science Foundation

**NSFNET** National Science Foundation NETwork

**NVCNFG** nonvolatile configuration

**OPCON** Operator Console

**OSI** open systems interconnection

**OSICP** OSI Control Protocol

**OSPF** Open Shortest Path First

**OUI** organization unique identifier

**PC** personal computer

**PCR** peak cell rate

**PDN** public data network

**PING** Packet internet groper

**PDU** protocol data unit

**PID** process identification

**P-P** Point-to-Point

**PPP** Point-to-Point Protocol

**PROM** programmable read-only memory

**PU** physical unit

**PVC** permanent virtual circuit

**RAM** random access memory

**RD** route descriptor

**REM** ring error monitor

**REV** receive

**RFC** Request for Comments

**RI** ring indicator; routing information

**RIF** routing information field

**RII** routing information indicator

<b>RIP</b>	Routing Information Protocol
<b>RISC</b>	reduced instruction-set computer
<b>RNR</b>	receive not ready
<b>ROM</b>	read-only memory
<b>ROpcon</b>	Remote Operator Console
<b>RPS</b>	ring parameter server
<b>RTMP</b>	Routing Table Maintenance Protocol
<b>RTP</b>	RouTing update Protocol
<b>RTS</b>	request to send
<b>Rtype</b>	route type
<b>rxmits</b>	retransmissions
<b>rxmt</b>	retransmit
<b>s</b>	second
<b>SAF</b>	source address filtering
<b>SAP</b>	service access point
<b>SAP</b>	Service Advertising Protocol
<b>SCR</b>	Sustained cell rate
<b>SCSP</b>	Server Cache Synchronization Protocol
<b>sdel</b>	start delimiter
<b>SDLC</b>	SDLC relay, synchronous data link control
<b>seqno</b>	sequence number
<b>SGID</b>	sever group id
<b>SGMP</b>	Simple Gateway Monitoring Protocol
<b>SL</b>	serial line
<b>SMP</b>	standby monitor present
<b>SMTP</b>	Simple Mail Transfer Protocol
<b>SNA</b>	Systems Network Architecture
<b>SNAP</b>	Subnetwork Access Protocol
<b>SNMP</b>	Simple Network Management Protocol
<b>SNPA</b>	subnetwork point of attachment
<b>SPF</b>	OSPF intra-area route
<b>SPE1</b>	OSPF external route type 1
<b>SPE2</b>	OSPF external route type 2
<b>SPIA</b>	OSPF inter-area route type
<b>SPID</b>	service profile ID
<b>SPX</b>	Sequenced Packet Exchange
<b>SQE</b>	signal quality error

**SRAM** static random access memory  
**SRB** source routing bridge  
**SRF** specifically routed frame  
**SRLY** SDLC relay  
**SRT** source routing transparent  
**SR-TB**  
source routing-transparent bridge  
**STA** static  
**STB** spanning tree bridge  
**STE** spanning tree explorer  
**STP** shielded twisted pair; spanning tree protocol  
**SVC** switched virtual circuit  
**TB** transparent bridge  
**TCN** topology change notification  
**TCP** Transmission Control Protocol  
**TCP/IP**  
Transmission Control Protocol/Internet Protocol  
**TEI** terminal point identifier  
**TFTP** Trivial File Transfer Protocol  
**TKR** token ring  
**TMO** timeout  
**TOS** type of service  
**TSF** transparent spanning frames  
**TTL** time to live  
**TTY** teletypewriter  
**TX** transmit  
**UA** unnumbered acknowledgment  
**UDP** User Datagram Protocol  
**UI** unnumbered information  
**UTP** unshielded twisted pair  
**VCC** Virtual Channel Connection  
**VINES** Virtual NEtworking System  
**VIR** variable information rate  
**VL** virtual link  
**VNI** Virtual Network Interface  
**VR** virtual route  
**WAN** wide area network  
**WRS** WAN restoral/reroute

**X.25** packet-switched networks  
**X.251** X.25 physical layer  
**X.252** X.25 frame layer  
**X.253** X.25 packet layer  
**XID** exchange identification  
**XNS** Xerox Network Systems  
**XSUM** checksum  
**ZIP** AppleTalk Zone Information Protocol  
**ZIP2** AppleTalk Zone Information Protocol 2  
**ZIT** Zone Information Table





---

# Glossary

This glossary includes terms and definitions from:

- The *American National Standard Dictionary for Information Systems*, ANSI X3.172-1990, copyright 1990 by the American National Standards Institute (ANSI). Copies may be purchased from the American National Standards Institute, 11 West 42nd Street, New York, New York 10036. Definitions are identified by the symbol (A) after the definition.
- The ANSI/EIA Standard—440-A, *Fiber Optic Terminology* Copies may be purchased from the Electronic Industries Association, 2001 Pennsylvania Avenue, N.W., Washington, DC 20006. Definitions are identified by the symbol (E) after the definition.
- The *Information Technology Vocabulary* developed by Subcommittee 1, Joint Technical Committee 1, of the International Organization for Standardization and the International Electrotechnical Commission (ISO/IEC JTC1/SC1). Definitions of published parts of this vocabulary are identified by the symbol (I) after the definition; definitions taken from draft international standards, committee drafts, and working papers being developed by ISO/IEC JTC1/SC1 are identified by the symbol (T) after the definition, indicating that final agreement has not yet been reached among the participating National Bodies of SC1.
- The *IBM Dictionary of Computing*, New York: McGraw-Hill, 1994.
- Internet Request for Comments: 1208, *Glossary of Networking Terms*
- Internet Request for Comments: 1392, *Internet Users' Glossary*
- The *Object-Oriented Interface Design: IBM Common User Access Guidelines*, Carmel, Indiana: Que, 1992.

The following cross-references are used in this glossary:

**Contrast with:**

This refers to a term that has an opposed or substantively different meaning.

**Synonym for:**

This indicates that the term has the same meaning as a preferred term, which is defined in its proper place in the glossary.

**Synonymous with:**

This is a backward reference from a defined term to all other terms that have the same meaning.

**See:** This refers the reader to multiple-word terms that have the same last word.

**See also:**

This refers the reader to terms that have a related, but not synonymous, meaning.

## A

**abstract syntax.** A data specification that includes all distinctions that are needed in data transmissions, but that omits (abstracts) other details such as those that depend on specific computer architectures. See also *abstract syntax notation 1 (ASN.1)* and *basic encoding rules (BER)*.

**abstract syntax notation 1 (ASN.1).** The Open Systems Interconnection (OSI) method for abstract syntax specified in the following standards:

- ITU-T Recommendation X.208 (1988) | ISO/IEC 8824: 1990
- ITU-T Recommendation X.680 (1994) | ISO/IEC 8824-1: 1994

See also *basic encoding rules (BER)*.

**ACCESS.** In the Simple Network Management Protocol (SNMP), the clause in a Management Information Base (MIB) module that defines the minimum level of support that a managed node provides for an object.

**acknowledgment.** (1) The transmission, by a receiver, of acknowledge characters as an affirmative response to a sender. (T) (2) An indication that an item sent was received.

**active.** (1) Operational. (2) Pertaining to a node or device that is connected or is available for connection to another node or device.

**active monitor.** In a token-ring network, a function performed at any one time by one ring station that initiates the transmission of tokens and provides token error recovery facilities. Any active adapter on the ring has the ability to provide the active monitor function if the current active monitor fails.

**address.** In data communication, the unique code assigned to each device, workstation, or user connected to a network.

**address mapping table (AMT).** A table, maintained within the AppleTalk router, that provides a current mapping of node addresses to hardware addresses.

**address mask.** For internet subnetworking, a 32-bit mask used to identify the subnetwork address bits in the host portion of an IP address. Synonymous with *subnet mask* and *subnetwork mask*.

**address resolution.** (1) A method for mapping network-layer addresses to media-specific addresses. (2) See also *Address Resolution Protocol (ARP)* and *AppleTalk Address Resolution Protocol (AARP)*.

**Address Resolution Protocol (ARP).** (1) In the Internet suite of protocols, the protocol that dynamically maps an IP address to an address used by a supporting metropolitan or local area network such as Ethernet or token-ring. (2) See also *Reverse Address Resolution Protocol (RARP)*.

**addressing.** In data communication, the way in which a station selects the station to which it is to send data.

**adjacent nodes.** Two nodes connected together by at least one path that connects no other node. (T)

**Administrative Domain.** A collection of hosts and routers, and the interconnecting networks, managed by a single administrative authority.

**Advanced Peer-to-Peer Networking (APPN).** An extension to SNA featuring (a) greater distributed network control that avoids critical hierarchical dependencies, thereby isolating the effects of single points of failure; (b) dynamic exchange of network topology information to foster ease of connection, reconfiguration, and adaptive route selection; (c) dynamic definition of network resources; and (d) automated resource registration and directory lookup. APPN extends the LU 6.2 peer orientation for end-user services to network control and supports multiple LU types, including LU 2, LU 3, and LU 6.2.

**Advanced Peer-to-Peer Networking (APPN) end node.** A node that provides a broad range of end-user services and supports sessions between its local control point (CP) and the CP in an adjacent network node. It uses these sessions to dynamically register its resources with the adjacent CP (its network node server), to send and receive directory search requests, and to obtain management services. An APPN end node can also attach to a subarea network as a peripheral node or to other end nodes.

**Advanced Peer-to-Peer Networking (APPN) network.** A collection of interconnected network nodes and their client end nodes.

**Advanced Peer-to-Peer Networking (APPN) network node.** A node that offers a broad range of end-user services and that can provide the following:

- Distributed directory services, including registration of its domain resources to a central directory server
- Topology database exchanges with other APPN network nodes, enabling network nodes throughout the network to select optimal routes for LU-LU sessions based on requested classes of service
- Session services for its local LUs and client end nodes
- Intermediate routing services within an APPN network

**Advanced Peer-to-Peer Networking (APPN) node.** An APPN network node or an APPN end node.

**agent.** A system that assumes an agent role.

**alert.** A message sent to a management services focal point in a network to identify a problem or an impending problem.

**all-stations address.** In communications, synonym for *broadcast address*.

**American National Standards Institute (ANSI).** An organization consisting of producers, consumers, and general interest groups, that establishes the procedures by which accredited organizations create and maintain voluntary industry standards in the United States. (A)

**analog.** (1) Pertaining to data consisting of continuously variable physical quantities. (A) (2) Contrast with *digital*.

**AppleTalk.** A network protocol developed by Apple Computer, Inc. This protocol is used to interconnect network devices, which can be a mixture of Apple and non-Apple products.

**AppleTalk Address Resolution Protocol (AARP).** In AppleTalk networks, a protocol that (a) translates AppleTalk node addresses into hardware addresses and (b) reconciles addressing discrepancies in networks that support more than one set of protocols.

**AppleTalk Transaction Protocol (ATP).** In AppleTalk networks, a protocol that provides client/server request and response functions for hosts accessing the Zone Information Protocol (ZIP) for zone information.

**APPN network.** See *Advanced Peer-to-Peer Networking (APPN) network*.

**APPN network node.** See *Advanced Peer-to-Peer Networking (APPN) network node*.

**arbitrary MAC addressing (AMA).** In DECnet architecture, an addressing scheme used by DECnet Phase IV-Prime that supports universally administered addresses and locally administered addresses.

**area.** In Internet and DECnet routing protocols, a subset of a network or gateway grouped together by

definition of the network administrator. Each area is self-contained; knowledge of an area's topology remains hidden from other areas.

**asynchronous (ASYNC).** Pertaining to two or more processes that do not depend upon the occurrence of specific events such as common timing signals. (T)

**attachment unit interface (AUI).** In a local area network, the interface between the medium attachment unit and the data terminal equipment within a data station. (I) (A)

**authentication failure.** In the Simple Network Management Protocol (SNMP), a trap that may be generated by an authentication entity when a requesting client is not a member of the SNMP community.

**autonomous system.** In TCP/IP, a group of networks and routers under one administrative authority. These networks and routers cooperate closely to propagate network reachability (and routing) information among themselves using an interior gateway protocol of their choice.

**autonomous system number.** In TCP/IP, a number assigned to an autonomous system by the same central authority that also assigns IP addresses. The autonomous system number makes it possible for automated routing algorithms to distinguish autonomous systems.

## B

**backbone.** (1) In a local area network multiple-bridge ring configuration, a high-speed link to which the rings are connected by means of bridges or routers. A backbone may be configured as a bus or as a ring. (2) In a wide area network, a high-speed link to which nodes or data switching exchanges (DSEs) are connected.

**backbone network.** A central network to which smaller networks, normally of lower speed, connect. The backbone network usually has a much higher capacity than the networks it helps interconnect or is a wide-area network (WAN) such as a public packet-switched datagram network.

**backbone router.** (1) A router used to transmit data between areas. (2) One in a series of routers that is used to interconnect networks into a larger internet.

**Bandwidth.** The bandwidth of an optical link designates the information-carrying capacity of the link and is related to the maximum bit rate that a fiber link can support.

**basic transmission unit (BTU).** In SNA, the unit of data and control information passed between path control components. A BTU can consist of one or more path information units (PIUs).

**baud.** In asynchronous transmission, the unit of modulation rate corresponding to one unit interval per second; that is, if the duration of the unit interval is 20 milliseconds, the modulation rate is 50 baud. (A)

**bootstrap.** (1) A sequence of instructions whose execution causes additional instructions to be loaded and executed until the complete computer program is in storage. (T) (2) A technique or device designed to bring itself into a desired state by means of its own action, for example, a machine routine whose first few instructions are sufficient to bring the rest of itself into the computer from an input device. (A)

**Border Gateway Protocol (BGP).** An Internet Protocol (IP) routing protocol used between domains and autonomous systems.

**border router.** In Internet communications, a router, positioned at the edge of an autonomous system, that communicates with a router that is positioned at the edge of a different autonomous system.

**bridge.** A functional unit that interconnects multiple LANs (locally or remotely) that use the same logical link control protocol but that can use different medium access control protocols. A bridge forwards a frame to another bridge based on the medium access control (MAC) address.

**bridge identifier.** An 8-byte field, used in a spanning tree protocol, composed of the MAC address of the port with the lowest port identifier and a user-defined value.

**bridging.** In LANs, the forwarding of a frame from one LAN segment to another. The destination is specified by the medium access control (MAC) sublayer address encoded in the destination address field of the frame header.

**broadcast.** (1) Transmission of the same data to all destinations. (T) (2) Simultaneous transmission of data to more than one destination. (3) Contrast with *multicast*.

**broadcast address.** In communications, a station address (eight 1's) reserved as an address common to all stations on a link. Synonymous with *all-stations address*.

## C

**cache.** (1) A special-purpose buffer storage, smaller and faster than main storage, used to hold a copy of instructions and data obtained from main storage and likely to be needed next by the processor. (T) (2) A buffer storage that contains frequently accessed instructions and data; it is used to reduce access time. (3) An optional part of the directory database in network nodes where frequently used directory information may be stored to speed directory searches. (4) To place, hide, or store in a cache.

**call request packet.** (1) A call supervision packet that a data terminal equipment (DTE) transmits to ask that a connection for a call be established throughout the network. (2) In X.25 communications, a call supervision packet transmitted by a DTE to ask for a call establishment through the network.

**canonical address.** In LANs, the IEEE 802.1 format for the transmission of medium access control (MAC) addresses for token-ring and Ethernet adapters. In canonical format, the least significant (rightmost) bit of each address byte is transmitted first. Contrast with *noncanonical address*.

**carrier.** An electric or electromagnetic wave or pulse train that may be varied by a signal bearing information to be transmitted over a communication system. (T)

**carrier detect.** Synonym for *received line signal detector (RLSD)*.

**carrier sense.** In a local area network, an ongoing activity of a data station to detect whether another station is transmitting. (T)

**carrier sense multiple access with collision detection (CSMA/CD).** A protocol that requires carrier sense and in which a transmitting data station that detects another signal while transmitting, stops sending, sends a jam signal, and then waits for a variable time before trying again. (T) (A)

**CCITT.** International Telegraph and Telephone Consultative Committee. This was an organization of the International Telecommunication Union (ITU). On 1 March 1993 the ITU was reorganized, and responsibilities for standardization were placed in a subordinate organization named the Telecommunication Standardization Sector of the Telecommunication Union (ITU-TS). "CCITT" continues to be used for recommendations that were approved before the reorganization.

**channel.** (1) A path along which signals can be sent, for example, data channel, output channel. (A) (2) A functional unit, controlled by the processor, that handles the transfer of data between processor storage and local peripheral equipment.

**channel service unit (CSU).** A unit that provides the interface to a digital network. The CSU provides line conditioning (or equalization) functions, which keep the signal's performance consistent across the channel bandwidth; signal reshaping, which constitutes the binary pulse stream; and loopback testing, which includes the transmission of test signals between the CSU and the network carrier's office channel unit. See also *data service unit (DSU)*.

**channelization.** The process of breaking the bandwidth on a communication line into a number of channels, possibly of different size. Also called *time division multiplexing* (TDM).

**checksum.** (1) The sum of a group of data associated with the group and used for checking purposes. (T) (2) In error detection, a function of all bits in a block. If the written and calculated sums do not agree, an error is indicated. (3) On a diskette, data written in a sector for error detection purposes; a calculated checksum that does not match the checksum of data written in the sector indicates a bad sector. The data are either numeric or other character strings regarded as numeric for the purpose of calculating the checksum.

**circuit switching.** (1) A process that, on demand, connects two or more data terminal equipment (DTEs) and permits the exclusive use of a data circuit between them until the connection is released. (I) (A) (2) Synonymous with *line switching*.

**class A network.** In Internet communications, a network in which the high-order (most significant) bit of the IP address is set to 0 and the host ID occupies the three low-order octets.

**class B network.** In Internet communications, a network in which the two high-order (most significant and next-to-most significant) bits of the IP address are set to 1 and 0, respectively, and the host ID occupies the two low-order octets.

**class of service (COS).** A set of characteristics (such as route security, transmission priority, and bandwidth) used to construct a route between session partners. The class of service is derived from a mode name specified by the initiator of a session.

**client.** (1) A functional unit that receives shared services from a server. (T) (2) A user.

**client/server.** In communications, the model of interaction in distributed data processing in which a program at one site sends a request to a program at another site and awaits a response. The requesting program is called a client; the answering program is called a server.

**clocking.** (1) In binary synchronous communication, the use of clock pulses to control synchronization of data and control characters. (2) A method of controlling the number of data bits sent on a telecommunication line in a given time.

**collision.** An unwanted condition that results from concurrent transmissions on a channel. (T)

**collision detection.** In carrier sense multiple access with collision detection (CSMA/CD), a signal indicating that two or more stations are transmitting simultaneously.

**Committed information rate.** The maximum amount of data in bits that the network agrees to deliver.

**community.** In the Simple Network Management Protocol (SNMP), an administrative relationship between entities.

**community name.** In the Simple Network Management Protocol (SNMP), a string of octets identifying a community.

**compression.** (1) The process of eliminating gaps, empty fields, redundancies, and unnecessary data to shorten the length of records or blocks. (2) Any encoding to reduce the number of bits used to represent a given message or record.

**configuration.** (1) The manner in which the hardware and software of an information processing system are organized and interconnected. (T) (2) The devices and programs that make up a system, subsystem, or network.

**configuration database (CDB).** A database that stores the configuration parameters of one or several devices. It is prepared and updated using the configuration program.

**configuration file.** A file that specifies the characteristics of a system device or network.

**configuration parameter.** A variable in a configuration definition, the values of which can characterize the relationship of a product to other products in the same network or can define characteristics of the product itself.

**configuration report server (CRS).** In the IBM Token-Ring Network Bridge Program, the server that accepts commands from the LAN Network Manager (LNM) to get station information, set station parameters, and remove stations on its ring. This server also collects and forwards configuration reports generated by stations on its ring. The configuration reports include the new active monitor reports and the nearest active upstream neighbor (NAUN) reports.

**congestion.** See *network congestion*.

**connection.** In data communication, an association established between functional units for conveying information. (I) (A)

**control point (CP).** (1) A component of an APPN or LEN node that manages the resources of that node. In an APPN node, the CP is capable of engaging in CP-CP sessions with other APPN nodes. In an APPN network node, the CP also provides services to adjacent end nodes in the APPN network. (2) A component of a node that manages resources of that node and optionally provides services to other nodes in the network. Examples are a system services control point (SSCP) in a type 5 subarea node, a network node control point (NNCP) in an APPN network node, and an

end node control point (ENCP) in an APPN or LEN end node. An SSCP and an NNCP can provide services to other nodes.

**control point management services (CPMS).** A component of a control point, consisting of management services function sets, that provides facilities to assist in performing problem management, performance and accounting management, change management, and configuration management. Capabilities provided by the CPMS include sending requests to physical unit management services (PUMS) to test system resources, collecting statistical information (for example, error and performance data) from PUMS about the system resources, and analyzing and presenting test results and statistical information collected about the system resources. Analysis and presentation responsibilities for problem determination and performance monitoring can be distributed among multiple CPMSs.

**control point management services unit (CP-MSU).** The message unit that contains management services data and flows between management services function sets. This message unit is in general data stream (GDS) format. See also *management services unit (MSU)* and *network management vector transport (NMVT)*.

## D

**D-bit.** Delivery-confirmation bit. In X.25 communications, the bit in a data packet or call-request packet that is set to 1 if end-to-end acknowledgment (delivery confirmation) is required from the recipient.

**daemon.** A program that runs unattended to perform a standard service. Some daemons are triggered automatically to perform their task; others operate periodically.

**data carrier detect (DCD).** Synonym for *received line signal detector (RLSD)*.

**data circuit.** (1) A pair of associated transmit and receive channels that provide a means of two-way data communication. (I) (2) In SNA, synonym for *link connection*. (3) See also *physical circuit* and *virtual circuit*.

### Notes:

1. Between data switching exchanges, the data circuit may include data circuit-terminating equipment (DCE), depending on the type of interface used at the data switching exchange.
2. Between a data station and a data switching exchange or data concentrator, the data circuit includes the data circuit-terminating equipment at the data station end, and may include equipment similar to a DCE at the data switching exchange or data concentrator location.

**data circuit-terminating equipment (DCE).** In a data station, the equipment that provides the signal

conversion and coding between the data terminal equipment (DTE) and the line. (I)

**Notes:**

1. The DCE may be separate equipment or an integral part of the DTE or of the intermediate equipment.
2. A DCE may perform other functions that are usually performed at the network end of the line.

**data link connection identifier (DLCI).** The numeric identifier of a frame-relay subport or PVC segment in a frame-relay network. Each subport in a single frame-relay port has a unique DLCI. The following table, excerpted from the American National Standards Institute (ANSI) Standard T1.618 and the International Telegraph and Telephone Consultative Committee (ITU-T/CCITT) Standard Q.922, indicates the functions associated with certain DLCI values:

DLCI Values	Function
0	in-channel signaling
1–15	reserved
16–991	assigned using frame-relay connection procedures
992–1007	layer 2 management of frame-relay bearer service
1008–1022	reserved
1023	in-channel layer management

**data link control (DLC).** A set of rules used by nodes on a data link (such as an SDLC link or a token ring) to accomplish an orderly exchange of information.

**data link control (DLC) layer.** In SNA, the layer that consists of the link stations that schedule data transfer over a link between two nodes and perform error control for the link. Examples of data link control are SDLC for serial-by-bit link connection and data link control for the System/370 channel.

**Note:** The DLC layer is usually independent of the physical transport mechanism and ensures the integrity of data that reaches the higher layers.

**data link layer.** In the Open Systems Interconnection reference model, the layer that provides services to transfer data between entities in the network layer over a communication link. The data link layer detects and possibly corrects errors that may occur in the physical layer. (T)

**data link level.** (1) In the hierarchical structure of a data station, the conceptual level of control or processing logic between high level logic and the data link that maintains control of the data link. The data link level performs such functions as inserting transmit bits and deleting receive bits; interpreting address and control fields; generating, transmitting, and interpreting commands and responses; and computing and

interpreting frame check sequences. See also *packet level* and *physical level*. (2) In X.25 communications, synonym for *frame level*.

**data link switching (DLSw).** A method of transporting network protocols that use IEEE 802.2 logical link control (LLC) type 2. SNA and NetBIOS are examples of protocols that use LLC type 2. See also *encapsulation* and *spoofing*.

**data packet.** In X.25 communications, a packet used for the transmission of user data on a virtual circuit at the DTE/DCE interface.

**data service unit (DSU).** A device that provides a digital data service interface directly to the data terminal equipment. The DSU provides loop equalization, remote and local testing capabilities, and a standard EIA/CCITT interface.

**data set ready (DSR).** Synonym for *DCE ready*.

**data switching exchange (DSE).** The equipment installed at a single location to provide switching functions, such as circuit switching, message switching, and packet switching. (I)

**data terminal equipment (DTE).** That part of a data station that serves as a data source, data sink, or both. (I) (A)

**data terminal ready (DTR).** A signal to the modem used with the EIA 232 protocol.

**data transfer rate.** The average number of bits, characters, or blocks per unit time passing between corresponding equipment in a data transmission system. (I)

**Notes:**

1. The rate is expressed in bits, characters, or blocks per second, minute, or hour.
2. Corresponding equipment should be indicated; for example, modems, intermediate equipment, or source and sink.

**datagram.** (1) In packet switching, a self-contained packet, independent of other packets, that carries information sufficient for routing from the originating data terminal equipment (DTE) to the destination DTE without relying on earlier exchanges between the DTEs and the network. (I) (2) In TCP/IP, the basic unit of information passed across the Internet environment. A datagram contains a source and destination address along with the data. An Internet Protocol (IP) datagram consists of an IP header followed by the transport layer data. (3) See also *packet* and *segment*.

**Datagram Delivery Protocol (DDP).** In AppleTalk networks, a protocol that provides network connectivity by means of connectionless socket-to-socket delivery service on the internet layer.

**DCE ready.** In the EIA 232 standard, a signal that indicates to the data terminal equipment (DTE) that the local data circuit-terminating equipment (DCE) is connected to the communication channel and is ready to send data. Synonymous with *data set ready (DSR)*.

**DECnet.** A network architecture that defines the operation of a family of software modules, databases, and hardware components typically used to tie Digital Equipment Corporation systems together for resource sharing, distributed computation, or remote system configuration. DECnet network implementations follow the Digital Network Architecture (DNA) model.

**default.** Pertaining to an attribute, condition, value, or option that is assumed when none is explicitly specified. (I)

**dependent LU requester (DLUR).** An APPN end node or an APPN network node that owns dependent LUs, but requests that a dependent LU server provide the SSCP services for those dependent LUs.

**designated router.** A router that informs end nodes of the existence and identity of other routers. The selection of the designated router is based upon the router with the highest priority. When several routers share the highest priority, the router with the highest station address is selected.

**destination node.** The node to which a request or data is sent.

**destination port.** The 8-port asynchronous adapter that serves as a connection point with a serial service.

**destination service access point (DSAP).** In SNA and TCP/IP, a logical address that allows a system to route data from a remote device to the appropriate communications support. Contrast with *source service access point (SSAP)*.

**device.** A mechanical, electrical, or electronic contrivance with a specific purpose.

**digital.** (1) Pertaining to data that consist of digits. (T) (2) Pertaining to data in the form of digits. (A) (3) Contrast with *analog*.

**Digital Network Architecture (DNA).** The model for all DECnet hardware and software implementations.

**direct memory access (DMA).** The system facility that allows a device on the Micro Channel bus to get direct access to the system or bus memory without the intervention of the system processor.

**directory.** A table of identifiers and references to the corresponding items of data. (I) (A)

**directory service (DS).** An application service element that translates the symbolic names used by application processes into the complete network addresses used in an OSI environment. (T)

**directory services (DS).** A control point component of an APPN node that maintains knowledge of the location of network resources.

**disable.** To make nonfunctional.

**disabled.** (1) Pertaining to a state of a processing unit that prevents the occurrence of certain types of interruptions. (2) Pertaining to the state in which a transmission control unit or audio response unit cannot accept incoming calls on a line.

**domain.** (1) That part of a computer network in which the data processing resources are under common control. (T) (2) In Open Systems Interconnection (OSI), a part of a distributed system or a set of managed objects to which a common policy applies. (3) See *Administrative Domain* and *domain name*.

**domain name.** In the Internet suite of protocols, a name of a host system. A domain name consists of a sequence of subnames separated by a delimiter character. For example, if the fully qualified domain name (FQDN) of a host system is `ra1vm7.vnet.ibm.com`, each of the following is a domain name:

- `ra1vm7.vnet.ibm.com`
- `vnet.ibm.com`
- `ibm.com`

**domain name server.** In the Internet suite of protocols, a server program that supplies name-to-address translation by mapping domain names to IP addresses. Synonymous with *name server*.

**Domain Name System (DNS).** In the Internet suite of protocols, the distributed database system used to map domain names to IP addresses.

**dotted decimal notation.** The syntactical representation for a 32-bit integer that consists of four 8-bit numbers written in base 10 with periods (dots) separating them. It is used to represent IP addresses.

**dump.** (1) Data that has been dumped. (T) (2) To copy the contents of all or part of virtual storage for the purpose of collecting error information.

**dynamic reconfiguration (DR).** The process of changing the network configuration (peripheral PUs and LUs) without regenerating complete configuration tables or deactivating the affected major node.

**Dynamic Routing.** Routing using learned routes rather than routes statically configured at initialization.

## E

**echo.** In data communication, a reflected signal on a communications channel. For example, on a communications terminal, each signal is displayed twice, once when entered at the local terminal and again when returned over the communications link. This allows the signals to be checked for accuracy.

**EIA 232.** In data communication, a specification of the Electronic Industries Association (EIA) that defines the interface between data terminal equipment (DTE) and data circuit-terminating equipment (DCE), using serial binary data interchange.

**Electronic Industries Association (EIA).** An organization of electronics manufacturers that advances the technological growth of the industry, represents the views of its members, and develops industry standards.

**EIA unit.** A unit of measure, established by the Electronic Industries Association, equal to 44.45 millimeters (1.75 inches).

**encapsulation.** (1) In communications, a technique used by layered protocols by which a layer adds control information to the protocol data unit (PDU) from the layer it supports. In this respect, the layer encapsulates the data from the supported layer. In the Internet suite of protocols, for example, a packet would contain control information from the physical layer, followed by control information from the network layer, followed by the application protocol data. (2) See also *data link switching*.

**encode.** To convert data by the use of a code in such a manner that reconversion to the original form is possible. (T)

**end node (EN).** (1) See *Advanced Peer-to-Peer Networking (APPN) end node* and *low-entry networking (LEN) end node*. (2) In communications, a node that is frequently attached to a single data link and cannot perform intermediate routing functions.

**entry point (EP).** In SNA, a type 2.0, type 2.1, type 4, or type 5 node that provides distributed network management support. It sends network management data about itself and the resources it controls to a focal point for centralized processing, and it receives and executes focal-point initiated commands to manage and control its resources.

**Ethernet.** A 10-Mbps baseband local area network that allows multiple stations to access the transmission medium at will without prior coordination, avoids contention by using carrier sense and deference, and resolves contention by using collision detection and delayed retransmission. Ethernet uses carrier sense multiple access with collision detection (CSMA/CD).

**exception.** An abnormal condition such as an I/O error encountered in processing a data set or a file.

**exception response (ER).** In SNA, a protocol requested in the form-of-response-requested field of a request header that directs the receiver to return a response only if the request is unacceptable as received or cannot be processed; that is, a negative response, but not a positive response, can be returned. Contrast with *definite response* and *no response*.

**exchange identification (XID).** A specific type of basic link unit that is used to convey node and link characteristics between adjacent nodes. XIDs are exchanged between link stations before and during link activation to establish and negotiate link and node characteristics, and after link activation to communicate changes in these characteristics.

**explicit route (ER).** In SNA, a series of one or more transmission groups that connect two subarea nodes. An explicit route is identified by an origin subarea address, a destination subarea address, an explicit route number, and a reverse explicit route number. Contrast with *virtual route (VR)*.

**explorer frame.** See *explorer packet*.

**explorer packet.** In LANs, a packet that is generated by the source host and that traverses the entire source routing part of a LAN, gathering information on the possible paths available to the host.

**exterior gateway.** In Internet communications, a gateway on one autonomous system that communicates with another autonomous system. Contrast with *interior gateway*.

**Exterior Gateway Protocol (EGP).** In the Internet suite of protocols, a protocol, used between domains and autonomous systems, that enables network reachability information to be advertised and exchanged. IP network addresses in one autonomous system are advertised to another autonomous system by means of EGP-participating routers. An example of an EGP is the Border Gateway Protocol (BGP). Contrast with Interior Gateway Protocol (IGP).

## F

**fax.** Hardcopy received from a facsimile machine. Synonymous with *telecopy*.

**File Transfer Protocol (FTP).** In the Internet suite of protocols, an application layer protocol that uses TCP and Telnet services to transfer bulk-data files between machines or hosts.

**flash memory.** A data storage device that is programmable, erasable, and does not require continuous power. The chief advantage of flash memory over other programmable and erasable data storage



devices is that it can be reprogrammed without being removed from the circuit board.

**flow control.** (1) In SNA, the process of managing the rate at which data traffic passes between components of the network. The purpose of flow control is to optimize the rate of flow of message units with minimum congestion in the network; that is, to neither overflow the buffers at the receiver or at intermediate routing nodes, nor leave the receiver waiting for more message units. (2) See also  *pacing*.

**fragment.** See  *fragmentation*.

**fragmentation.** (1) The process of dividing a datagram into smaller parts, or fragments, to match the capabilities of the physical medium over which it is to be transmitted. (2) See also  *segmenting*.

**frame.** (1) In Open Systems Interconnection architecture, a data structure pertaining to a particular area of knowledge and consisting of slots that can accept the values of specific attributes and from which inferences can be drawn by appropriate procedural attachments. (T) (2) The unit of transmission in some local area networks, including the IBM Token-Ring Network. It includes delimiters, control characters, information, and checking characters. (3) In SDLC, the vehicle for every command, every response, and all information that is transmitted using SDLC procedures.

**frame level.** Synonymous with  *data link level*. See  *link level*.

**frame relay.** (1) An interface standard describing the boundary between a user's equipment and a fast-packet network. In frame-relay systems, flawed frames are discarded; recovery comes end-to-end rather than hop-by-hop. (2) A technique derived from the integrated services digital network (ISDN) D channel standard. It assumes that connections are reliable and dispenses with the overhead of error detection and control within the network.

**front-end processor.** A processor such as the IBM 3745 or 3174, that relieves a main frame from the communication control tasks.

## G

**gateway.** (1) A functional unit that interconnects two computer networks with different network architectures. A gateway connects networks or systems of different architectures. A bridge interconnects networks or systems with the same or similar architectures. (T) (2) In the IBM Token-Ring Network, a device and its associated software that connect a local area network to another local area network or a host that uses different logical link protocols. (3) In TCP/IP, synonym for  *router*.

**general data stream (GDS).** The data stream used for conversations in LU 6.2 sessions.

**general data stream (GDS) variable.** A type of RU substructure that is preceded by an identifier and a length field and includes either application data, user control data, or SNA-defined control data.

## H

**header.** (1) System-defined control information that precedes user data. (2) The portion of a message that contains control information for the message such as one or more destination fields, name of the originating station, input sequence number, character string indicating the type of message, and priority level for the message.

**heap memory.** The amount of RAM used to dynamically allocate data structures.

**Hello.** A protocol used by a group of cooperating, trusting routers to allow them to discover minimal delay routes.

**hello message.** (1) A message sent periodically to establish and test reachability between routers or between routers and hosts. (2) In the Internet suite of protocols, a message defined by the Hello protocol as an Interior Gateway Protocol (IGP).

**heuristic.** Pertaining to exploratory methods of problem solving in which solutions are discovered by evaluation of the progress made toward the final result.

**high-level data link control (HDLC).** In data communication, the use of a specified series of bits to control data links in accordance with the International Standards for HDLC: ISO 3309 Frame Structure and ISO 4335 Elements of Procedures.

**high-performance routing (HPR).** An addition to the Advanced Peer-to-Peer Networking (APPN) architecture that enhances data routing performance and reliability, especially when using high-speed links.

**hop.** (1) In APPN, a portion of a route that has no intermediate nodes. It consists of only a single transmission group connecting adjacent nodes. (2) To the routing layer, the logical distance between two nodes in a network.

**hop count.** (1) A metric or measure of distance between two points. (2) In Internet communications, the number of routers that a datagram passes through on its way to its destination. (3) In SNA, a measure of the number of links to be traversed in a path to a destination.

**host.** In the Internet suite of protocols, an end system. The end system can be any workstation; it does not have to be a mainframe.

**hub (intelligent).** A wiring concentrator, such as the IBM 8260, that provides bridging and routing functions for LANs with different cables and protocols.

**hysteresis.** The amount the temperature must change past the set alert threshold before the alert condition is cleared.

I

**I-frame.** Information frame.

**information (I) frame.** A frame in I format used for numbered information transfer.

**input/output channel.** In a data processing system, a functional unit that handles transfer of data between internal and peripheral equipment. (I) (A)

**Integrated Digital Network Exchange (IDNX).** A processor integrating voice, data, and image applications. It also manages the transmission resources, and connects to multiplexers and network management support systems. It allows integration of equipment from different vendors.

**integrated services digital network (ISDN).** A digital end-to-end telecommunication network that supports multiple services including, but not limited to, voice and data.

**Note:** ISDNs are used in public and private network architectures.

**interface.** (1) A shared boundary between two functional units, defined by functional characteristics, signal characteristics, or other characteristics, as appropriate. The concept includes the specification of the connection of two devices having different functions. (T) (2) Hardware, software, or both, that links systems, programs, or devices.

**interior gateway.** In Internet communications, a gateway that communicates only with its own autonomous system. Contrast with *exterior gateway*.

**Interior Gateway Protocol (IGP).** In the Internet suite of protocols, a protocol used to propagate network reachability and routing information within an autonomous system. Examples of IGPs are Routing Information Protocol (RIP) and Open Shortest Path First (OSPF).

**intermediate node.** A node that is at the end of more than one branch. (T)

**intermediate session routing (ISR).** A type of routing function within an APPN network node that provides session-level flow control and outage reporting for all sessions that pass through the node but whose end points are elsewhere.

**International Organization for Standardization (ISO).** An organization of national standards bodies from various countries established to promote development of standards to facilitate international exchange of goods and services, and develop cooperation in intellectual, scientific, technological, and economic activity.

**International Telecommunication Union (ITU).** The specialized telecommunication agency of the United Nations, established to provide standardized communication procedures and practices, including frequency allocation and radio regulations worldwide.

**internet.** A collection of networks interconnected by a set of routers that allow them to function as a single, large network. See also *Internet*.

**Internet.** The internet administered by the Internet Architecture Board (IAB), consisting of large national backbone networks and many regional and campus networks all over the world. The Internet uses the Internet suite of protocols.

**Internet address.** See *IP address*.

**Internet Architecture Board (IAB).** The technical body that oversees the development of the Internet suite of protocols that are known as TCP/IP.

**Internet Control Message Protocol (ICMP).** The protocol used to handle errors and control messages in the Internet Protocol (IP) layer. Reports of problems and incorrect datagram destinations are returned to the original datagram source. ICMP is part of the Internet Protocol.

**Internet Control Protocol (ICP).** The Virtual Networking System (VINES) protocol that provides exception notifications, metric notifications, and PING support. See also *Routing update Protocol (RTP)*.

**Internet Engineering Task Force (IETF).** The task force of the Internet Architecture Board (IAB) that is responsible for solving the short-term engineering needs of the Internet.

**Internetwork Packet Exchange (IPX).** (1) The network protocol used to connect Novell's servers, or any workstation or router that implements IPX, with other workstations. Although similar to the Internet Protocol (IP), IPX uses different packet formats and terminology. (2) See also *Xerox Network Systems (XNS)*.

**Internet Protocol (IP).** A connectionless protocol that routes data through a network or interconnected networks. IP acts as an intermediary between the higher protocol layers and the physical network. However, this protocol does not provide error recovery and flow control and does not guarantee the reliability of the physical network.

**interoperability.** The capability to communicate, execute programs, or transfer data among various functional units in a way that requires the user to have little or no knowledge of the unique characteristics of those units. (T)

**intra-area routing.** In Internet communications, the routing of data within an area.

**Inverse Address Resolution Protocol (InARP).** In the Internet suite of protocols, the protocol used for locating a protocol address through the known hardware address. In a frame-relay context, the data link connection identifier (DLCI) is synonymous with the known hardware address.

**IPPN.** The interface that other protocols can use to transport data over IP.

**IP address.** The 32-bit address defined by the Internet Protocol, standard 5, Request for Comments (RFC) 791. It is usually represented in dotted decimal notation.

**IP datagram.** In the Internet suite of protocols, the fundamental unit of information transmitted through an internet. It contains source and destination addresses, user data, and control information such as the length of the datagram, the header checksum, and flags indicating whether the datagram can be or has been fragmented.

**IP router.** A device in an IP internet that is responsible for making decisions about the paths over which network traffic will flow. Routing protocols are used to gain information about the network and to determine the best route over which the datagram should be forwarded toward the final destination. The datagrams are routed based on IP destination addresses.

**IPXWAN.** A Novell protocol that is used to exchange router-to-router information before exchanging standard Internetwork Packet Exchange (IPX) routing information and traffic over wide area networks (WANs).

## J

**jitter.** (1) Short-term non-cumulative variations of the significant instants of a digital signal from their ideal positions in time. (2) Undesirable variations of a transmitted digital signal. (3) Variations in the network delay.

## L

**LAN bridge server (LBS).** In the IBM Token-Ring Network Bridge Program, the server that keeps statistical information about frames forwarded between two or more rings (through a bridge). The LBS sends these statistics to the appropriate LAN managers through the LAN reporting mechanism (LRM).

**LAN Network Manager (LNM).** An IBM licensed program that enables a user to manage and monitor LAN resources from a central workstation.

**LAN segment.** (1) Any portion of a LAN (for example, a bus or ring) that can operate independently, but that is connected to other parts of the network by means of bridges. (2) A ring or bus network without bridges.

**layer.** (1) In network architecture, a group of services that is complete from a conceptual point of view, that is one out of a set of hierarchically arranged groups, and that extends across all systems that conform to the network architecture. (T) (2) In the Open Systems Interconnection reference model, one of seven conceptually complete, hierarchically arranged groups of services, functions, and protocols, that extend across all open systems. (T) (3) In SNA, a grouping of related functions that are logically separate from the functions in other groups. Implementation of the functions in one layer can be changed without affecting functions in other layers.

**line switching.** Synonym for *circuit switching*.

**link.** The combination of the link connection (the transmission medium) and two link stations, one at each end of the link connection. A link connection can be shared among multiple links in a multipoint or token-ring configuration.

**link access protocol balanced (LAPB).** A protocol used for accessing an X.25 network at the link level. LAPB is a duplex, asynchronous, symmetric protocol, used in point-to-point communication.

**link-attached.** (1) Pertaining to devices that are connected to a controlling unit by a data link. (2) Contrast with *channel-attached*. (3) Synonymous with *remote*.

**link connection.** (1) The physical equipment providing two-way communication between one link station and one or more other link stations; for example, a telecommunication line and data circuit-terminating equipment (DCE). (2) In SNA, synonymous with *data circuit*.

**link level.** (1) A part of Recommendation X.25 that defines the link protocol used to get data into and out of the network across the full-duplex link connecting the subscriber's machine to the network node. LAP and LAPB are the link access protocols recommended by the CCITT. (2) See *data link level*.

**link-state.** In routing protocols, the advertised information about the usable interfaces and reachable neighbors of a router or network. The protocol's topological database is formed from the collected link-state advertisements.

**link station.** (1) The hardware and software components within a node representing a connection to

an adjacent node over a specific link. For example, if node A is the primary end of a multipoint line that connects to three adjacent nodes, node A will have three link stations representing the connections to the adjacent nodes. (2) See also *adjacent link station (ALS)*.

**local.** (1) Pertaining to a device accessed directly without use of a telecommunication line. (2) Contrast with *remote*. (3) Synonym for *channel-attached*.

**local area network (LAN).** (1) A computer network located on a user's premises within a limited geographical area. Communication within a local area network is not subject to external regulations; however, communication across the LAN boundary may be subject to some form of regulation. (T) (2) A network in which a set of devices are connected to one another for communication and that can be connected to a larger network. (3) See also *Ethernet* and *token ring*. (4) Contrast with *metropolitan area network (MAN)* and *wide area network (WAN)*.

**local bridging.** A function of a bridge program that allows a single bridge to connect multiple LAN segments without using a telecommunication link. Contrast with *remote bridging*.

**local management interface (LMI).** See *local management interface (LMI) protocol*.

**local management interface (LMI) protocol.** In NCP, a set of frame-relay network management procedures and messages used by adjacent frame-relay nodes to exchange line status information over DLCI X'00'. NCP supports both the American National Standards Institute (ANSI) and International Telegraph and Telephone Consultative Committee (ITU-T/CCITT) versions of LMI protocol. These standards refer to LMI protocol as *link integrity verification tests (LIVT)*.

**locally administered address.** In a local area network, an adapter address that the user can assign to override the universally administered address. Contrast with *universally administered address*.

**logical channel.** In packet mode operation, a sending channel and a receiving channel that together are used to send and receive data over a data link at the same time. Several logical channels can be established on the same data link by interleaving the transmission of packets.

**logical link.** A pair of link stations, one in each of two adjacent nodes, and their underlying link connection, providing a single link-layer connection between the two nodes. Multiple logical links can be distinguished while they share the use of the same physical media connecting two nodes. Examples are 802.2 logical links used on local area network (LAN) facilities and LAP E logical links on the same point-to-point physical link between two nodes. The term logical link also includes the multiple X.25 logical channels that share the use of the access link from a DTE to an X.25 network.

**logical link control (LLC).** The data link control (DLC) LAN sublayer that provides two types of DLC operation for the orderly exchange of information. The first type is connectionless service, which allows information to be sent and received without establishing a link. The LLC sublayer does not perform error recovery or flow control for connectionless service. The second type is connection-oriented service, which requires establishing a link prior to the exchange of information. Connection-oriented service provides sequenced information transfer, flow control, and error recovery.

**logical link control (LLC) protocol.** In a local area network, the protocol that governs the exchange of transmission frames between data stations independently of how the transmission medium is shared. (T) The LLC protocol was developed by the IEEE 802 committee and is common to all LAN standards.

**logical link control (LLC) protocol data unit.** A unit of information exchanged between link stations in different nodes. The LLC protocol data unit contains a destination service access point (DSAP), a source service access point (SSAP), a control field, and user data.

**logical unit (LU).** A type of network accessible unit that enables users to gain access to network resources and communicate with each other.

**loopback test.** A test in which signals from a tester are looped at a modem or other network element back to the tester for measurements that determine or verify the quality of the communications path.

**low-entry networking (LEN).** A capability of nodes to attach directly to one another using basic peer-to-peer protocols to support multiple and parallel sessions between logical units.

**low-entry networking (LEN) end node.** A LEN node receiving network services from an adjacent APPN network node.

**low-entry networking (LEN) node.** A node that provides a range of end-user services, attaches directly to other nodes using peer protocols, and derives network services implicitly from an adjacent APPN network node, that is, without the direct use of CP-CP sessions.

## M

**Management Information Base (MIB).** (1) A collection of objects that can be accessed by means of a network management protocol. (2) A definition for management information that specifies the information available from a host or gateway and the operations allowed. (3) In OSI, the conceptual repository of management information within an open system.

**management station.** In Internet communications, the system responsible for managing all, or a portion of, a network. The management station communicates with network management agents that reside in the managed node by means of a network management protocol, such as the Simple Network Management Protocol (SNMP).

**mapping.** The process of converting data that is transmitted in one format by the sender into the data format that can be accepted by the receiver.

**mask.** (1) A pattern of characters used to control retention or elimination of portions of another pattern of characters. (I) (A) (2) To use a pattern of characters to control retention or elimination of portions of another pattern of characters. (I) (A)

**maximum transmission unit (MTU).** In LANs, the largest possible unit of data that can be sent on a given physical medium in a single frame. For example, the MTU for Ethernet is 1500 bytes.

**medium access control (MAC).** In LANs, the sublayer of the data link control layer that supports medium-dependent functions and uses the services of the physical layer to provide services to the logical link control (LLC) sublayer. The MAC sublayer includes the method of determining when a device has access to the transmission medium.

**medium access control (MAC) protocol.** In a local area network, the protocol that governs access to the transmission medium, taking into account the topological aspects of the network, in order to enable the exchange of data between data stations. (T)

**medium access control (MAC) sublayer.** In a local area network, the part of the data link layer that applies a medium access method. The MAC sublayer supports topology-dependent functions and uses the services of the physical layer to provide services to the logical link control sublayer. (T)

**metric.** In Internet communications, a value, associated with a route, which is used to discriminate between multiple exit or entry points to the same autonomous system. The route with the lowest metric is preferred.

**metropolitan area network (MAN).** A network formed by the interconnection of two or more networks which may operate at higher speed than those networks, may cross administrative boundaries, and may use multiple access methods. (T) Contrast with *local area network (LAN)* and *wide area network (WAN)*.

**MIB.** (1) MIB module. (2) Management Information Base.

**MIB object.** Synonym for *MIB variable*.

**MIB variable.** In the Simple Network Management Protocol (SNMP), a specific instance of data defined in a MIB module. Synonymous with *MIB object*.

**MIB view.** In the Simple Network Management Protocol (SNMP), the collection of managed objects, known to the agent, that is visible to a particular community.

**MILNET.** The military network that was originally part of ARPANET. It was partitioned from ARPANET in 1984. MILNET provides a reliable network service for military installations.

**modem (modulator/demodulator).** (1) A functional unit that modulates and demodulates signals. One of the functions of a modem is to enable digital data to be transmitted over analog transmission facilities. (T) (A) (2) A device that converts digital data from a computer to an analog signal that can be transmitted on a telecommunication line, and converts the analog signal received to data for the computer.

**module.** In the Nways Switch, a packaged functional hardware unit containing logic cards, connectors, and lights. The modules are used to package adapters, line interface couplers, voice server extensions, and other components. All modules are *hot pluggable* in the logic subracks.

**modulo.** (1) Pertaining to a modulus; for example, 9 is equivalent to 4 modulo 5. (2) See also *modulus*.

**modulus.** A number, such as a positive integer, in a relationship that divides the difference between two related numbers without leaving a remainder; for example, 9 and 4 have a modulus of 5 ( $9 - 4 = 5$ ;  $4 - 9 = -5$ ; and 5 divides both 5 and -5 without leaving a remainder).

**monitor.** (1) A device that observes and records selected activities within a data processing system for analysis. Possible uses are to indicate significant departure from the norm, or to determine levels of utilization of particular functional units. (T) (2) Software or hardware that observes, supervises, controls, or verifies operations of a system. (A) (3) The function required to initiate the transmission of a token on the ring and to provide soft-error recovery in case of lost tokens, circulating frames, or other difficulties. The capability is present in all ring stations.

**multicast.** (1) Transmission of the same data to a selected group of destinations. (T) (2) A special form of broadcast in which copies of a packet are delivered to only a subset of all possible destinations.

**multipath channel (MPC).** A channel protocol that uses multiple unidirectional subchannels for VTAM-to-VTAM bidirectional communication.

**multiple-domain support (MDS).** A technique for transporting management services data between

management services function sets over LU-LU and CP-CP sessions. See also *multiple-domain support message unit (MDS-MU)*.

**multiple-domain support message unit (MDS-MU).** The message unit that contains management services data and flows between management services function sets over the LU-LU and CP-CP sessions used by multiple-domain support. This message unit, as well as the actual management services data that it contains, is in general data stream (GDS) format. See also *control point management services unit (CP-MSU)*, *management services unit (MSU)*, and *network management vector transport (NMVT)*.

## N

**Name Binding Protocol (NBP).** In AppleTalk networks, a protocol that provides name translation function from the AppleTalk entity (resource) name (character string) into an AppleTalk IP address (16-bit number) on the transport layer.

**name resolution.** In Internet communications, the process of mapping a machine name to the corresponding Internet Protocol (IP) address. See also *Domain Name System (DNS)*.

**name server.** In the Internet suite of protocols, synonym for *domain name server*.

**nearest active upstream neighbor (NAUN).** In the IBM Token-Ring Network, the station sending data directly to a given station on the ring.

**neighbor.** A router on a common subnetwork that has been designated by a network administrator to receive routing information.

**NetBIOS.** Network Basic Input/Output System. A standard interface to networks, IBM personal computers (PCs), and compatible PCs, that is used on LANs to provide message, print-server, and file-server functions. Application programs that use NetBIOS do not need to handle the details of LAN data link control (DLC) protocols.

**network.** (1) A configuration of data processing devices and software connected for information interchange. (2) A group of nodes and the links interconnecting them.

**Network Access Server (NAS).** A device providing temporary, on-demand network access to users. This access is point-to-point using PSTN or ISDN lines.

**network accessible unit (NAU).** A logical unit (LU), physical unit (PU), control point (CP), or system services control point (SSCP). It is the origin or the destination of information transmitted by the path control network. Synonymous with *network addressable unit*.

**network address.** According to ISO 7498-3, a name, unambiguous within the OSI environment, that identifies a set of network service access points.

**network addressable unit (NAU).** Synonym for *network accessible unit*.

**network architecture.** The logical structure and operating principles of a computer network. (T)

**Note:** The operating principles of a network include those of services, functions, and protocols.

**network congestion.** An undesirable overload condition caused by traffic in excess of what a network can handle.

**network identifier.** (1) In TCP/IP, that part of the IP address that defines a network. The length of the network ID depends on the type of network class (A, B, or C). (2) A 1- to 8-byte customer-selected name or an 8-byte IBM-registered name that uniquely identifies a specific subnetwork.

**Network Information Center (NIC).** In Internet communications, local, regional, and national groups throughout the world who provide assistance, documentation, training, and other services to users.

**network layer.** In Open Systems Interconnection (OSI) architecture, the layer that is responsible for routing, switching, and link-layer access across the OSI environment.

**network management.** The process of planning, organizing, and controlling a communication-oriented data processing or information system.

**network management station.** In the Simple Network Management Protocol (SNMP), a station that executes management application programs that monitor and control network elements.

**network management vector transport (NMVT).** A management services request/response unit (RU) that flows over an active session between physical unit management services and control point management services (SSCP-PU session).

**network manager.** A program or group of programs that is used to monitor, manage, and diagnose the problems of a network.

**network node (NN).** See *Advanced Peer-to-Peer Networking (APPN) network node*.

**network support station.** The processor used to locally operate and service the Nways Switch. It is used by the Nways Switch administrator or service personnel.

**network user address (NUA).** In X.25 communications, the X.121 address containing up to 15 binary code digits.

**node.** (1) In a network, a point at which one or more functional units connect channels or data circuits. (I)  
(2) Any device, attached to a network, that transmits and receives data.

**noncanonical address.** In LANs, a format for the transmission of medium access control (MAC) addresses for token-ring adapters. In noncanonical format, the most significant (leftmost) bit of each address byte is transmitted first. Contrast with *canonical address*.

**Non-Return-to-Zero Changes-on-Ones Recording (NRZ-1).** A recording method in which the ones are represented by a change in the condition of magnetization, and zeros are represented by the absence of change. Only the one signals are explicitly recorded. (Previously called *non-return-to-zero inverted*, NRZI, recording.)

**nonseed router.** In AppleTalk networks, a router that acquires network number range and zone list information from a seed router attached to the same network.

**Nways Switch.** Synonymous with IBM 2220 Nways BroadBand Switch.

**Nways Switch configuration station.** A dedicated OS/2 station running a stand-alone version of the Nways Switch Configuration Tool (NCT). It is used to generate a network configuration database and should be installed as a remote console.

## O

**Open Shortest Path First (OSPF).** In the Internet suite of protocols, a function that provides intradomain information transfer. An alternative to the Routing Information Protocol (RIP), OSPF allows the lowest-cost routing and handles routing in large regional or corporate networks.

**Open Systems Interconnection (OSI).** (1) The interconnection of open systems in accordance with standards of the International Organization for Standardization (ISO) for the exchange of information. (T) (A) (2) The use of standardized procedures to enable the interconnection of data processing systems.

**Note:** OSI architecture establishes a framework for coordinating the development of current and future standards for the interconnection of computer systems. Network functions are divided into seven layers. Each layer represents a group of related data processing and communication functions that can be carried out in a standard way to support different applications.

**Open Systems Interconnection (OSI) architecture.** Network architecture that adheres to that particular set of ISO standards that relates to Open Systems Interconnection. (T)

**Open Systems Interconnection (OSI) reference model.** A model that describes the general principles of the Open Systems Interconnection, as well as the purpose and the hierarchical arrangement of its seven layers. (T)

**origin.** An external logical unit (LU) or application program from which a message or other data originates. See also *destination*.

**orphan circuit.** A non-configured circuit whose availability is learned dynamically.

## P

**padding.** (1) A technique by which a receiving component controls the rate of transmission of a sending component to prevent overrun or congestion. (2) See also *flow control*, *receive pacing*, *send pacing*, *session-level pacing*, and *virtual route (VR) pacing*.

**packet.** In data communication, a sequence of binary digits, including data and control signals, that is transmitted and switched as a composite whole. The data, control signals, and, possibly, error control information are arranged in a specific format. (I)

**packet internet groper (PING).** (1) In Internet communications, a program used in TCP/IP networks to test the ability to reach destinations by sending the destinations an Internet Control Message Protocol (ICMP) echo request and waiting for a reply. (2) In communications, a test of reachability.

**packet loss ratio.** The probability that a packet will not reach its destination or not reach it within a specified time.

**packet mode operation.** Synonym for *packet switching*.

**packet switching.** (1) The process of routing and transferring data by means of addressed packets so that a channel is occupied only during transmission of a packet. On completion of the transmission, the channel is made available for transfer of other packets. (I) (2) Synonymous with *packet mode operation*. See also *circuit switching*.

**parallel bridges.** A pair of bridges connected to the same LAN segment, creating redundant paths to the segment.

**parallel transmission groups.** Multiple transmission groups between adjacent nodes, with each group having a distinct transmission group number.

**path.** (1) In a network, any route between any two nodes. A path may include more than one branch. (T) (2) The series of transport network components (path control and data link control) that are traversed by the information exchanged between two network accessible units. See also *explicit route (ER)*, *route extension*, and *virtual route (VR)*.

**path control (PC).** The function that routes message units between network accessible units in the network and provides the paths between them. It converts the basic information units (BIUs) from transmission control (possibly segmenting them) into path information units (PIUs) and exchanges basic transmission units containing one or more PIUs with data link control. Path control differs by node type: some nodes (APPN nodes, for example) use locally generated session identifiers for routing, and others (subarea nodes) use network addresses for routing.

**path cost.** In link-state routing protocols, the sum of the link costs along the path between two nodes or networks.

**path information unit (PIU).** A message unit consisting of a transmission header (TH) alone, or a TH followed by a basic information unit (BIU) or a BIU segment.

**pattern-matching character.** A special character such as an asterisk (\*) or a question mark (?) that can be used to represent one or more characters. Any character or set of characters can replace a pattern-matching character. Synonymous with *global character* and *wildcard character*.

**permanent virtual circuit (PVC).** In X.25 and frame-relay communications, a virtual circuit that has a logical channel permanently assigned to it at each data terminal equipment (DTE). Call-establishment protocols are not required. Contrast with *switched virtual circuit (SVC)*.

**physical circuit.** A circuit established without multiplexing. See also *data circuit*. Contrast with *virtual circuit*.

**physical layer.** In the Open Systems Interconnection reference model, the layer that provides the mechanical, electrical, functional, and procedural means to establish, maintain, and release physical connections over the transmission medium. (T)

**physical unit (PU).** (1) The component that manages and monitors the resources (such as attached links and adjacent link stations) associated with a node, as requested by an SSCP via an SSCP-PU session. An SSCP activates a session with the physical unit in order to indirectly manage, through the PU, resources of the node such as attached links. This term applies to type 2.0, type 4, and type 5 nodes only. (2) See also *peripheral PU* and *subarea PU*.

**ping command.** The command that sends an Internet Control Message Protocol (ICMP) echo-request packet to a gateway, router, or host with the expectation of receiving a reply.

**Point-to-Point Protocol (PPP).** A protocol that provides a method for encapsulating and transmitting packets over serial point-to-point links.

**polling.** (1) On a multipoint connection or a point-to-point connection, the process whereby data stations are invited, one at a time, to transmit. (I) (2) Interrogation of devices for such purposes as to avoid contention, to determine operational status, or to determine readiness to send or receive data. (A)

**port.** (1) An access point for data entry or exit. (2) A connector on a device to which cables for other devices such as display stations and printers are attached. (3) The representation of a physical connection to the link hardware. A port is sometimes referred to as an adapter; however, there can be more than one port on an adapter. There may be one or more ports controlled by a single DLC process. (4) In the Internet suite of protocols, a 16-bit number used to communicate between TCP or the User Datagram Protocol (UDP) and a higher-level protocol or application. Some protocols, such as File Transfer Protocol (FTP) and Simple Mail Transfer Protocol (SMTP), use the same well-known port number in all TCP/IP implementations. (5) An abstraction used by transport protocols to distinguish among multiple destinations within a host machine. (6) Synonymous with *socket*.

**port number.** In Internet communications, the identification of an application entity to the transport service.

**private branch exchange (PBX).** A private telephone exchange for transmission of calls to and from the public telephone network.

**problem determination.** The process of determining the source of a problem; for example, a program component, machine failure, telecommunication facilities, user or contractor-installed programs or equipment, environmental failure such as a power loss, or user error.

**program temporary fix (PTF).** A temporary solution or bypass of a problem diagnosed by IBM in a current unaltered release of the program.

**protocol.** (1) A set of semantic and syntactic rules that determine the behavior of functional units in achieving communication. (I) (2) In Open Systems Interconnection architecture, a set of semantic and syntactic rules that determine the behavior of entities in the same layer in performing communication functions. (T) (3) In SNA, the meanings of, and the sequencing rules for, requests and responses used for managing the network, transferring data, and synchronizing the states of network components.



Synonymous with *line control discipline* and *line discipline*. See *bracket protocol* and *link protocol*.

**protocol data unit (PDU).** A unit of data specified in a protocol of a given layer and consisting of protocol control information of this layer, and possibly user data of this layer. (T)

**pulse code modulation (PCM).** A standard adopted for the digitalization of an analog voice signal. In PCM, the voice is sampled at a rate of eight kHz and each sample is coded in an 8-bit frame.

## R

**Rapid Transport Protocol (RTP) connection.** In high-performance routing (HPR), the connection established between the endpoints of the route to transport session traffic.

**reachability.** The ability of a node or a resource to communicate with another node or resource.

**read-only memory (ROM).** Memory in which stored data cannot be modified by the user except under special conditions.

**real-time processing.** The manipulation of data that are required, or generated, by some process while the process is in operation. Usually the results are used to influence the process, and perhaps related processes, while it is occurring.

**reassembly.** In communications, the process of putting segmented packets back together after they have been received.

**receive not ready (RNR).** In communications, a data link command or response that indicates a temporary condition of being unable to accept incoming frames.

**receive not ready (RNR) packet.** See *RNR packet*.

**received line signal detector (RLSD).** In the EIA 232 standard, a signal that indicates to the data terminal equipment (DTE) that it is receiving a signal from the remote data circuit-terminating equipment (DCE). Synonymous with *carrier detect* and *data carrier detect (DCD)*.

**Recognized Private Operating Agency (RPOA).** Any individual, company, or corporation, other than a government department or service, that operates a telecommunication service and is subject to the obligations undertaken in the Convention of the International Telecommunication Union and in the Regulations; for example, a communication common carrier.

**reduced instruction-set computer (RISC).** A computer that uses a small, simplified set of frequently used instructions for rapid execution.

**remote.** (1) Pertaining to a system, program, or device that is accessed through a telecommunication line. (2) Synonym for *link-attached*. (3) Contrast with *local*.

**remote bridging.** The function of a bridge that allows two bridges to connect multiple LANs using a telecommunication link. Contrast with *local bridging*.

**remote console.** A station running OS/2, TCP/IP, and the remote Nways Switch Resource Control program. It can be connected to any network support station to operate and service the Nways Switch remotely. The connection may be through:

- A switched line using a modem

Any network support station can be used as a remote console of another network support station.

**Remote Execution Protocol (REXEC).** A protocol that allows the execution of a command or program on any host in the network. The local host receives the results of the command execution.

**Request for Comments (RFC).** In Internet communications, the document series that describes a part of the Internet suite of protocols and related experiments. All Internet standards are documented as RFCs.

**reset.** On a virtual circuit, reinitialization of data flow control. At reset, all data in transit are eliminated.

**reset request packet.** In X.25 communications, a packet transmitted by the data terminal equipment (DTE) to the data circuit-terminating equipment (DCE) to request that a virtual call or a permanent virtual circuit be reset. The reason for the request can also be specified in the packet.

**resource.** In the Nways Switch, an hardware element or a logical entity created by the Control Program. For example, the adapters, LICs, and lines are physical resources. The control points and connections are logical resources.

**ring.** See *ring network*.

**ring network.** (1) A network in which every node has exactly two branches connected to it and in which there are exactly two paths between any two nodes. (T) (2) A network configuration in which devices are connected by unidirectional transmission links to form a closed path.

**ring segment.** A section of a ring that can be isolated (by unplugging connectors) from the rest of the ring. See *LAN segment*.

**rlogin (remote login).** A service, offered by Berkeley UNIX-based systems, that allows authorized users of one machine to connect to other UNIX systems across an internet and interact as if their terminals were connected directly. The rlogin software passes

information about the user's environment (for example, terminal type) to the remote machine.

**RNR packet.** A packet used by a data terminal equipment (DTE) or by a data circuit-terminating equipment (DCE) to indicate a temporary inability to accept additional packets for a virtual call or permanent virtual circuit.

**root bridge.** The bridge that is the root of a spanning tree formed between other active bridges in the bridging network. The root bridge originates and transmits bridge protocol data units (BPDUs) to other active bridges to maintain the spanning tree topology. It is the bridge with the highest priority in the network.

**route.** (1) An ordered sequence of nodes and transmission groups (TGs) that represent a path from an origin node to a destination node traversed by the traffic exchanged between them. (2) The path that network traffic uses to get from source to destination.

**route bridge.** A function of an IBM bridge program that allows two bridge computers to use a telecommunication link to connect two LANs. Each bridge computer is connected directly to one of the LANs, and the telecommunication link connects the two bridge computers.

**route extension (REX).** In SNA, the path control network components, including a peripheral link, that make up the portion of a path between a subarea node and a network addressable unit (NAU) in an adjacent peripheral node. See also *explicit route (ER)*, *path*, and *virtual route (VR)*.

**Route Selection control vector (RSCV).** A control vector that describes a route within an APPN network. The RSCV consists of an ordered sequence of control vectors that identify the TGs and nodes that make up the path from an origin node to a destination node.

**router.** (1) A computer that determines the path of network traffic flow. The path selection is made from several paths based on information obtained from specific protocols, algorithms that attempt to identify the shortest or best path, and other criteria such as metrics or protocol-specific destination addresses. (2) An attaching device that connects two LAN segments, which use similar or different architectures, at the reference model network layer. (3) In OSI terminology, a function that determines a path by which an entity can be reached. (4) In TCP/IP, synonymous with *gateway*. (5) Contrast with *bridge*.

**routing.** (1) The assignment of the path by which a message is to reach its destination. (2) In SNA, the forwarding of a message unit along a particular path through a network, as determined by parameters carried in the message unit, such as the destination network address in a transmission header.

**routing domain.** In Internet communications, a group of intermediate systems that use a routing protocol so that the representation of the overall network is the same within each intermediate system. Routing domains are connected to each other by exterior links.

**Routing Information Protocol (RIP).** In the Internet suite of protocols, an interior gateway protocol used to exchange intradomain routing information and to determine optimum routes between internet hosts. RIP determines optimum routes on the basis of route metrics, not link transmission speed.

**routing loop.** A situation that occurs when routers circulate information among themselves until convergence occurs or until the networks involved are considered unreachable.

**routing protocol.** A technique used by a router to find other routers and to remain up to date about the best way to get to reachable networks.

**routing table.** A collection of routes used to direct datagram forwarding or to establish a connection. The information is passed among routers to identify network topology and destination feasibility.

**Routing Table Maintenance Protocol (RTMP).** In AppleTalk networks, a protocol that provides routing information generation and maintenance on the transport layer by means of the AppleTalk routing table. The AppleTalk routing table directs packet transmission through the internet from source socket to destination socket.

**RouTing update Protocol (RTP).** The Virtual NEtworking System (VINES) protocol that maintains the routing database and allows the exchange of routing information between VINES nodes. See also *Internet Control Protocol (ICP)*.

**rsh.** A variant of the rlogin command that invokes a command interpreter on a remote UNIX machine and passes the command-line arguments to the command interpreter, skipping the login step completely.

## S

**SAP.** See service access point.

**seed router.** In AppleTalk networks, a router that maintains configuration data (network range numbers and zone lists, for example) for the network. Each network must have at least one seed router. The seed router must be initially set up using the configurator tool. Contrast with *nonseed router*.

**segment.** (1) A section of cable between components or devices. A segment may consist of a single patch cable, several patch cables that are connected, or a combination of building cable and patch cables that are connected. (2) In Internet communications, the unit of

transfer between TCP functions in different machines. Each segment contains control and data fields; the current byte-stream position and actual data bytes are identified along with a checksum to validate received data.

**segmenting.** In OSI, a function performed by a layer to map one protocol data unit (PDU) from the layer it supports into multiple PDUs.

**sequence number.** In communications, a number assigned to a particular frame or packet to control the transmission flow and receipt of data.

**Serial Line Internet Protocol (SLIP).** A protocol used over a point-to-point connection between two IP hosts over a serial line, for example, a serial cable or an RS232 connection into a modem, over a telephone line.

**server.** A functional unit that provides shared services to workstations over a network; for example, a file server, a print server, a mail server. (T)

**service access point (SAP).** (1) In Open Systems Interconnection (OSI) architecture, the point at which the services of a layer are provided by an entity of that layer to an entity of the next higher layer. (T) (2) A logical point made available by an adapter where information can be received and transmitted. A single service access point can have many links terminating in it.

**Service Advertising Protocol (SAP).** In Internetwork Packet Exchange (IPX), a protocol that provides the following:

- A mechanism that allows IPX servers on an internet to advertise their services by name and type. Servers using this protocol have their name, service type, and address recorded in all file servers running NetWare.
- A mechanism that allows a workstation to broadcast a query to discover the identities of all servers of all types, all servers of a specific type, or the nearest server of a specific type.
- A mechanism that allows a workstation to query any file server running NetWare to discover the names and addresses of all servers of a specific type.

**session.** (1) In network architecture, for the purpose of data communication between functional units, all the activities which take place during the establishment, maintenance, and release of the connection. (T) (2) A logical connection between two network accessible units (NAUs) that can be activated, tailored to provide various protocols, and deactivated, as requested. Each session is uniquely identified in a transmission header (TH) accompanying any transmissions exchanged during the session.

**Simple Network Management Protocol (SNMP).** In the Internet suite of protocols, a network management protocol that is used to monitor routers and attached networks. SNMP is an application layer protocol.

Information on devices managed is defined and stored in the application's Management Information Base (MIB).

**SNA management services (SNA/MS).** The services provided to assist in management of SNA networks.

**socket.** (1) An endpoint for communication between processes or application programs. (2) The abstraction provided by the University of California's Berkeley Software Distribution (commonly called Berkeley UNIX or BSD UNIX) that serves as an endpoint for communication between processes or applications.

**source route bridging.** In LANs, a bridging method that uses the routing information field in the IEEE 802.5 medium access control (MAC) header of a frame to determine which rings or token-ring segments the frame must transit. The routing information field is inserted into the MAC header by the source node. The information in the routing information field is derived from explorer packets generated by the source host.

**source routing.** In LANs, a method by which the sending station determines the route the frame will follow and includes the routing information with the frame. Bridges then read the routing information to determine whether they should forward the frame.

**source service access point (SSAP).** In SNA and TCP/IP, a logical address that allows a system to send data to a remote device from the appropriate communications support. Contrast with *destination service access point (DSAP)*.

**spanning tree.** In LAN contexts, the method by which bridges automatically develop a routing table and update that table in response to changing topology to ensure that there is only one route between any two LANs in the bridged network. This method prevents packet looping, where a packet returns in a circuitous route back to the sending router.

**sphere of control (SOC).** The set of control point domains served by a single management services focal point.

**sphere of control (SOC) node.** A node directly in the sphere of control of a focal point. A SOC node has exchanged management services capabilities with its focal point. An APPN end node can be a SOC node if it supports the function to exchange management services capabilities.

**split horizon.** A technique for minimizing the time to achieve network convergence. A router records the interface over which it received a particular route and does not propagate its information about the route back over the same interface.

**spoofing.** For data links, a technique in which a protocol initiated from an end station is acknowledged and processed by an intermediate node on behalf of the

final destination. In IBM 6611 data link switching, for example, SNA frames are encapsulated into TCP/IP packets for transport across a non-SNA wide area network, unpacked by another IBM 6611, and passed to the final destination. A benefit of spoofing is the prevention of end-to-end session timeouts.

**standard MIB.** In the Simple Network Management Protocol (SNMP), a MIB module that is located under the management branch of the Structure of Management Information (SMI) and that is considered a standard by the Internet Engineering Task Force (IETF).

**static route.** The route between hosts, networks, or both that is manually entered into a routing table.

**station.** An input or output point of a system that uses telecommunication facilities; for example, one or more systems, computers, terminals, devices, and associated programs at a particular location that can send or receive data over a telecommunication line.

**StreetTalk.** In the Virtual NEtworking System (VINES), a unique network-wide naming and addressing system that allows users to locate and access any resource on the network without knowing the network topology. See also *Internet Control Protocol (ICP)* and *RouTing update Protocol (RTP)*.

**Structure of Management Information (SMI).** (1) In the Simple Network Management Protocol (SNMP), the rules used to define the objects that can be accessed by means of a network management protocol. (2) In OSI, the set of standards relating to management information. The set includes the *Management Information Model* and the *Guidelines for the Definition of Managed Objects*

**subarea.** A portion of the SNA network consisting of a subarea node, attached peripheral nodes, and associated resources. Within a subarea node, all network accessible units (NAUs), links, and adjacent link stations (in attached peripheral or subarea nodes) that are addressable within the subarea share a common subarea address and have distinct element addresses.

**subnet.** (1) In TCP/IP, a part of a network that is identified by a portion of the IP address. (2) Synonym for *subnetwork*.

**subnet address.** In Internet communications, an extension to the basic IP addressing scheme where a portion of the host address is interpreted as the local network address.

**subnet mask.** Synonym for *address mask*.

**subnetwork.** (1) Any group of nodes that have a set of common characteristics, such as the same network ID. (2) Synonymous with *subnet*.

**Subnetwork Access Protocol (SNAP).** In LANs, a 5-byte protocol discriminator that identifies the non-IEEE standard protocol family to which a packet belongs. The SNAP value is used to differentiate between protocols that use \$AA as their service access point (SAP) value.

**subnetwork mask.** Synonym for *address mask*.

**subsystem.** A secondary or subordinate system, usually capable of operating independently of, or asynchronously with, a controlling system. (T)

**switched virtual circuit (SVC).** An X.25 circuit that is dynamically established when needed. The X.25 equivalent of a switched line. Contrast with *permanent virtual circuit (PVC)*.

**synchronous.** (1) Pertaining to two or more processes that depend upon the occurrence of specific events such as common timing signals. (T) (2) Occurring with a regular or predictable time relationship.

**Synchronous Data Link Control (SDLC).** (1) A discipline conforming to subsets of the Advanced Data Communication Control Procedures (ADCCP) of the American National Standards Institute (ANSI) and High-level Data Link Control (HDLC) of the International Organization for Standardization, for managing synchronous, code-transparent, serial-by-bit information transfer over a link connection. Transmission exchanges may be duplex or half-duplex over switched or nonswitched links. The configuration of the link connection may be point-to-point, multipoint, or loop. (I) (2) Contrast with *binary synchronous communication (BSC)*.

**synchronous optical network (SONET).** A US standard for transmitting digital information over optical interfaces. It is closely related to the synchronous digital hierarchy (SDH) recommendation.

**SYNTAX.** In the Simple Network Management Protocol (SNMP), a clause in the MIB module that defines the abstract data structure that corresponds to a managed object.

**system.** In data processing, a collection of people, machines, and methods organized to accomplish a set of specific functions. (I) (A)

**system configuration.** A process that specifies the devices and programs that form a particular data processing system.

**system services control point (SSCP).** A component within a subarea network for managing the configuration, coordinating network operator and problem determination requests, and providing directory services and other session services for users of the network. Multiple SSCPs, cooperating as peers with one another, can divide the network into domains of control,

with each SSCP having a hierarchical control relationship to the physical units and logical units within its own domain.

**Systems Network Architecture (SNA).** The description of the logical structure, formats, protocols, and operational sequences for transmitting information units through, and controlling the configuration and operation of, networks. The layered structure of SNA allows the ultimate origins and destinations of information, that is, the users, to be independent of and unaffected by the specific SNA network services and facilities used for information exchange.

## T

**TCP/IP.** (1) Transmission Control Protocol/Internet Protocol. (2) A UNIX-like/Ethernet-based system-interconnect protocol originally developed by the US Department of Defense. TCP/IP facilitated ARPANET (Advanced Research Projects Agency Network), a packet-switched research network for which layer 4 was TCP and layer 3, IP.

**Telnet.** In the Internet suite of protocols, a protocol that provides remote terminal connection service. It allows users of one host to log on to a remote host and interact as directly attached terminal users of that host.

**threshold.** (1) In IBM bridge programs, a value set for the maximum number of frames that are not forwarded across a bridge due to errors, before a “threshold exceeded” occurrence is counted and indicated to network management programs. (2) An initial value from which a counter is decremented to 0, or a value to which a counter is incremented or decremented from an initial value.

**throughput class.** In packet switching, the speed at which data terminal equipment (DTE) packets travel through the packet switching network.

**time division multiplexing (TDM).** See *channelization*.

**time to live (TTL).** A technique used by best-effort delivery protocols to inhibit endlessly looping packets. The packet is discarded if the TTL counter reaches 0.

**timeout.** (1) An event that occurs at the end of a predetermined period of time that began at the occurrence of another specified event. (l) (2) A time interval allotted for certain operations to occur; for example, response to polling or addressing before system operation is interrupted and must be restarted.

**token.** (1) In a local area network, the symbol of authority passed successively from one data station to another to indicate the station temporarily in control of the transmission medium. Each data station has an opportunity to acquire and use the token to control the medium. A token is a particular message or bit pattern

that signifies permission to transmit. (T) (2) In LANs, a sequence of bits passed from one device to another along the transmission medium. When the token has data appended to it, it becomes a frame.

**token ring.** (1) According to IEEE 802.5, network technology that controls media access by passing a token (special packet or frame) between media-attached stations. (2) IEEE 802.5 network with a ring topology that passes tokens from one attaching ring station (node) to another. (3) See also *local area network (LAN)*.

**token-ring network.** (1) A ring network that allows unidirectional data transmission between data stations, by a token passing procedure, such that the transmitted data return to the transmitting station. (T) (2) A network that uses a ring topology, in which tokens are passed in a circuit from node to node. A node that is ready to send can capture the token and insert data for transmission.

**topology.** In communications, the physical or logical arrangement of nodes in a network, especially the relationships among nodes and the links between them.

**topology database update (TDU).** A message about a new or changed link or node that is broadcast among APPN network nodes to maintain the network topology database, which is fully replicated in each network node. A TDU contains information that identifies the following:

- The sending node
- The node and link characteristics of various resources in the network
- The sequence number of the most recent update for each of the resources described.

**trace.** (1) A record of the execution of a computer program. It exhibits the sequences in which the instructions were executed. (A) (2) For data links, a record of the frames and bytes transmitted or received.

**transceiver (transmitter-receiver).** In LANs, a physical device that connects a host interface to a local area network, such as Ethernet. Ethernet transceivers contain electronics that apply signals to the cable and that sense collisions.

**Transmission Control Protocol (TCP).** A communications protocol used in the Internet and in any network that follows the U.S. Department of Defense standards for internetwork protocol. TCP provides a reliable host-to-host protocol between hosts in packet-switched communications networks and in interconnected systems of such networks. It uses the Internet Protocol (IP) as the underlying protocol.

**Transmission Control Protocol/Internet Protocol (TCP/IP).** A set of communications protocols that support peer-to-peer connectivity functions for both local and wide area networks.

**transmission group (TG).** (1) A connection between adjacent nodes that is identified by a transmission group number. (2) In a subarea network, a single link or a group of links between adjacent nodes. When a transmission group consists of a group of links, the links are viewed as a single logical link, and the transmission group is called a *multilink transmission group (MLTG)*. A *mixed-media multilink transmission group (MMMLTG)* is one that contains links of different medium types (for example, token-ring, switched SDLC, nonswitched SDLC, and frame-relay links). (3) In an APPN network, a single link between adjacent nodes. (4) See also *parallel transmission groups*.

**transmission header (TH).** Control information, optionally followed by a basic information unit (BIU) or a BIU segment, that is created and used by path control to route message units and to control their flow within the network. See also *path information unit*.

**transparent bridging.** In LANs, a method for tying individual local area networks together through the medium access control (MAC) level. A transparent bridge stores the tables that contain MAC addresses so that frames seen by the bridge can be forwarded to another LAN if the tables indicate to do so.

**transport layer.** In the Open Systems Interconnection reference model, the layer that provides a reliable end-to-end data transfer service. There may be relay open systems in the path. (T) See also *Open Systems Interconnection reference model*.

**trap.** In the Simple Network Management Protocol (SNMP), a message sent by a managed node (agent function) to a management station to report an exception condition.

**trunk line.** A high-speed line connecting two Nways Switches. It can be a coaxial cable, fiber cable, or radio wave, for example, and may be leased from telecommunication companies.

**T1.** In the United States, a 1.544-Mbps public access line. It is available in twenty-four 64-Kbps channels. The European version (E1) transmits 2.048 Mbps.

## U

**universally administered address.** In a local area network, the address permanently encoded in an adapter at the time of manufacture. All universally administered addresses are unique. Contrast with *locally administered address*.

**User Datagram Protocol (UDP).** In the Internet suite of protocols, a protocol that provides unreliable, connectionless datagram service. It enables an application program on one machine or process to send a datagram to an application program on another machine or process. UDP uses the Internet Protocol (IP) to deliver datagrams.

## V

**V.24.** In data communication, a specification of the CCITT that defines the list of definitions for interchange circuits between data terminal equipment (DTE) and data circuit-terminating equipment (DCE).

**V.25.** In data communication, a specification of the CCITT that defines the automatic answering equipment and parallel automatic calling equipment on the General Switched Telephone Network, including procedures for disabling of echo controlled devices for both manually and automatically established calls.

**V.34.** An ITU-T Recommendation for modem communication over standard commercially available voice-grade 33.6-Kbps (and slower) channels.

**V.35.** In data communication, a specification of the CCITT that defines the list of definitions for interchange circuits between data terminal equipment (DTE) and data circuit-terminating equipment (DCE) at various data rates.

**V.36.** In data communication, a specification of the CCITT that defines the list of definitions for interchange circuits between data terminal equipment (DTE) and data circuit-terminating equipment (DCE) at rates of 48, 56, 64, or 72 kilobits per second.

**version.** A separately licensed program that usually has significant new code or new function.

**VINES.** Virtual NETworking System.

**virtual circuit.** (1) In packet switching, the facilities provided by a network that give the appearance to the user of an actual connection. (T) See also *data circuit*. Contrast with *physical circuit*. (2) A logical connection established between two DTEs.

**virtual connection.** In frame relay, the return path of a potential connection.

**virtual link.** In Open Shortest Path First (OSPF), a point-to-point interface that connects border routers that are separated by a non-backbone transit area. Because area routers are part of the OSPF backbone, the virtual link connects the backbone. The virtual links ensure that the OSPF backbone does not become discontinuous.

**Virtual NETworking System (VINES).** The network operating system and network software from Banyan Systems, Inc. In a VINES network, virtual linking allows all devices and services to appear to be directly connected to each other, when they may actually be thousands of miles apart. See also *StreetTalk*.

**virtual route (VR).** (1) In SNA, either (a) a logical connection between two subarea nodes that is physically realized as a particular explicit route or (b) a logical connection that is contained wholly within a subarea node for intranode sessions. A virtual route

between distinct subarea nodes imposes a transmission priority on the underlying explicit route, provides flow control through virtual route pacing, and provides data integrity through sequence numbering of path information units (PIUs). (2) Contrast with *explicit route (ER)*. See also *path* and *route extension (REX)*.

## W

**wide area network (WAN).** (1) A network that provides communication services to a geographic area larger than that served by a local area network or a metropolitan area network, and that may use or provide public communication facilities. (T) (2) A data communication network designed to serve an area of hundreds or thousands of miles; for example, public and private packet-switching networks, and national telephone networks. (3) Contrast with *local area network (LAN)* and *metropolitan area network (MAN)*.

**wildcard character.** Synonym for *pattern-matching character*.

## X

**X.21.** An International Telegraph and Telephone Consultative Committee (CCITT) recommendation for a general-purpose interface between data terminal equipment and data circuit-terminating equipment for synchronous operations on a public data network.

**X.25.** (1) An International Telegraph and Telephone Consultative Committee (CCITT) recommendation for the interface between data terminal equipment and packet-switched data networks. (2) See also *packet switching*.

**Xerox Network Systems (XNS).** The suite of internet protocols developed by the Xerox Corporation. Although similar to TCP/IP protocols, XNS uses different packet formats and terminology. See also *Internetwork Packet Exchange (IPX)*.

## Z

**zone.** In AppleTalk networks, a subset of nodes within an internet.

**Zone Information Protocol (ZIP).** In AppleTalk networks, a protocol that provides zone management service by maintaining a mapping of the zone names and network numbers across the internet on the session layer.

**zone information table (ZIT).** A listing of network numbers and their associated zone name mappings in the internet. This listing is maintained by each internet router in an AppleTalk internet.





---

# Index

## A

- accounting and node statistics 40
- activate\_new\_config
  - APPN configuration command 174
- add
  - AppleTalk Phase 2 configuration command 204
  - APPN configuration command 122
  - IPv6 configuration command 333
  - IPv6 update packet filter configuration command 345
  - NDP configuration command 355
  - OSI configuration command 287
  - RIP6 configuration command 375
  - VINES configuration command 223
- Address Resolution Protocol (ARP)
  - VINES 220
- addresses
  - OSI/DECnet V monitoring command 312
- aping
  - APPN monitoring command 191
- AppleTalk Control Protocol
  - for PPP 196
- AppleTalk Phase 2
  - basic configuration procedures 195, 198
  - configuring 195
  - monitoring 203
  - network parameters 195, 198
  - router parameters 195
- AppleTalk Phase 2 configuration commands
  - add 204
  - delete 205
  - disable 206
  - enable 207
  - list 208
  - set 209
- AppleTalk Phase 2 monitoring commands
  - atecho 211
  - cache 212
  - clear counters 213
  - counters 213
  - dump 213
  - interface 214
- APPN
  - monitoring 190
- APPN (DLSw) 27
- APPN configuration commands
  - activate\_new\_config 174
  - add 122
  - delete 173
  - enable/disable 81
  - list 174
  - set 81
  - TN3270 79
- APPN Frame Relay BAN Connection Network 44, 160, 161
- APPN monitoring commands
  - accessing 190

- APPN monitoring commands (*continued*)
  - aping 191
  - dump 192
  - list 192
  - memory 193
  - restart 193
  - stop 193
  - summary 191
  - tn3270e 193
  - transmit 194
- atecho
  - AppleTalk Phase 2 monitoring command 211

## B

- before you configure 37
- Border Node
  - COS mapping table 171
  - routing list 168
- Branch Extender 13, 16, 30, 147, 148, 149

## C

- cache
  - AppleTalk Phase 2 monitoring command 212
  - IPv6 monitoring command 348
- change
  - IPv6 configuration command 337
  - IPv6 update packet filter configuration command 345
  - NDP configuration command 357
  - RIP6 configuration command 376
- change metric
  - OSI/DECnet V monitoring command 313
- change prefix-address 293
- clear 295
  - PIM monitoring command 366
- Client IP Address to LU Name Mapping 22
- CLNP protocol 268
- clnp-Stats
  - OSI/DECnet V monitoring command 313
- command summary
  - DNA IV 247
- configurable Held Alert Queue 19, 36, 120
- configuration changes, affect on the router 26
- configuration options 26
- configuration requirements 26
- connection networks 12
- COS 37
- COS mapping table 35
- counters
  - AppleTalk Phase 2 monitoring command 213
  - IPv6 monitoring command 348
  - VINES monitoring command 227

## D

- DDD LU 20
  - TN3270E Server and 23

- DECnet NCP
  - See NCP 231
- delete
  - AppleTalk Phase 2 configuration command 205
  - APPN configuration command 173
  - IPV6 configuration command 337
  - IPV6 update packet filter configuration command 346
  - NDP configuration command 358
  - OSI configuration command 296
  - PIM configuration command 361
  - RIP6 configuration command 377
  - VINES configuration command 224
- Dial on Demand 51
  - APPN using 51
- Digital Network Architecture (DNA) phase IV 231
- disable
  - AppleTalk Phase 2 configuration command 206
  - APPN configuration command 81
  - IPV6 configuration command 338
  - NDP configuration command 359
  - OSI configuration command 298
  - PIM configuration command 362
  - RIP6 configuration command 377
  - VINES configuration command 224
- DLUR 8, 36, 41
- DLUR retry algorithm 41
- DNA IV
  - access control
    - configuring 236
    - exclusive 237
    - inclusive 236
    - managing traffic 235
  - addressing
    - 802.5 Token 232
    - description 232
    - Ethernet data link 232
  - area routers
    - description 233
    - level 1 234
    - level 2 234
  - area routing filters 238
  - area support of 231
  - blending domains 240
  - configuration
    - for X.25 244
  - designated router for 233
  - LAT protocol 231
  - MOP support of 231
  - Network Control Program (NCP) 234
    - See NCP 231
  - routing 233
  - routing parameters 234
  - routing tables 233
  - special considerations and limitations 231
  - terminology and concepts 232
- DNA IV configuration commands
  - define
    - circuit 248
    - executor 251
    - module access 254
- DNA IV configuration commands (*continued*)
  - define (*continued*)
    - module routing 255
    - node 255
  - help 248
  - purge
    - module access 256
    - module routing 256
  - show
    - area 257
    - node 258
  - show/list
    - circuit 259
    - executor 262
    - module access 264
    - module routing 264
  - zero
    - circuit 265
    - executor 265
    - module access 265
- DNA IV monitoring commands
  - define
    - circuit 248
    - executor 251
    - module access 254
    - module routing 255
    - node 255
  - help 248
  - purge
    - module access 256
    - module routing 256
  - show
    - area 257
    - node 258
  - show/list
    - circuit 259
    - executor 262
    - module access 264
    - routing 264
  - zero
    - circuit 265
    - executor 265
    - module access 265
    - module\_access 265
- DNA V
  - networks 243
  - X.25 configuration
    - Count 2 244
- DNAV-info
  - OSI/DECnet V monitoring command 315
- dump
  - AppleTalk Phase 2 monitoring command 213
  - APPN monitoring command 192
  - IPV6 monitoring command 349
  - NDP monitoring command 360
  - PIM monitoring command 366
  - RIP6 monitoring command 381
  - VINES 228
- Dynamic Definition of Dependent LUs 20
  - TN3270E Server and 23

## E

- enable
  - AppleTalk Phase 2 configuration command 207
  - APPN configuration command 81
  - IPv6 configuration command 338
  - NDP configuration command 359
  - OSI configuration command 299
  - PIM configuration command 362
  - RIP6 configuration command 378
  - VINES configuration command 224
- Enterprise Extender Support for HPR over IP 25
- es-adjacencies
  - OSI/DECnet V monitoring command 316
- ES-IS protocol 268
  - description 281
  - hello message 281
- es-is-stats
  - OSI/DECnet V monitoring command 316
- exit
  - VINES monitoring command 230
- Extended Border Node 14, 16
  - configuring 31
  - COS mapping table 35
  - network requirements 16
  - routing list 33

## F

- features
  - IP version 6 (IPv6) 327
- focal point 17, 36

## H

- How LUs are chosen for client connections 23
- HPR 6, 36

## I

- implementation on the router 3
- implicit focal point 19, 166
- interface
  - AppleTalk Phase 2 monitoring command 214
  - IPv6 monitoring command 349
  - PIM monitoring command 367
- intermediate session data, collecting 40
- IP
  - packet size 384
- IPv6
  - configuring 333
- IPv6
  - overview 327
  - using 327
- ipv6 command 333
- IPv6 configuration commands
  - add 333
  - change 337
  - delete 337
  - disable 338
  - enable 338
  - list 339

## IPv6 configuration commands *(continued)*

- set 341
  - summary 333
  - update 344
- ## IPv6 monitoring commands
- accessing 347
  - cache 348
  - counters 348
  - dump 349
  - interface 349
  - mcast 349
  - mld 350
  - packet-filter 351
  - path-mtu 351
  - ping6 351
  - route 350
  - sizes 350
  - static 351
  - summary of 348
  - traceroute 372
  - traceroute6 352
  - tunnels 353
- ## IPv6 update packet filter configuration commands
- add 345
  - change 345
  - delete 346
  - list 347
  - move 346
- ## is-adjacencies
- OSI/DECnet V monitoring command 318
- ## IS-IS messages
- IS to IS hello (IIH) messages 274
  - point-to-point 275
- ## IS-IS protocol
- description 271
  - IS-IS areas 271
  - IS-IS domain 272
  - IS to IS hello (IIH) messages
    - L1 274
  - IS to IS Hello (IIH) messages
    - L2 275
  - overview 268
- ## is-is-stats
- OSI/DECnet V monitoring command 318
- ## ISDN Permanent Circuit
- APPN using 49
- ## ISDN permanent connection 49

## J

- join
  - PIM monitoring command 367

## L

- l1-routes
  - OSI/DECnet V monitoring command 320
- l1-Summary
  - OSI/DECnet V monitoring command 321
- l1-Update
  - OSI/DECnet V monitoring command 322

- I2-Routes
  - OSI/DECnet V monitoring command 320
- I2-Summary
  - OSI/DECnet V monitoring command 322
- I2-Update
  - OSI/DECnet V monitoring command 323
- leave
  - PIM monitoring command 368
- link level parameter lists 48
- list
  - AppleTalk Phase 2 configuration command 208
  - APPN configuration command 174
  - APPN monitoring command 192
  - IPV6 configuration command 339
  - IPV6 update packet filter configuration command 347
  - NDP configuration command 359
  - NDP monitoring command 360
  - OSI configuration command 299
  - PIM configuration command 362
  - RIP6 configuration command 380
  - RIP6 monitoring command 381
  - VINES configuration command 225
- Local Area Terminal (LAT) protocol 231
- LU parameter list 48
- LU Pooling 21

## M

- managing network nodes 17
- managing the router network node 17
- mcache
  - PIM monitoring command 368
- mcast
  - IPV6 monitoring command 349
- memory
  - APPN monitoring command 193
- mgroup
  - PIM monitoring command 368
- mld
  - IPV6 monitoring command 350
- monitoring
  - APPN 190
  - IPV6 monitoring commands 348
  - NDP monitoring commands 360
  - PIM monitoring commands 366
  - RIP6 monitoring commands 381
- move
  - IPV6 update packet filter configuration command 346
- mstats
  - PIM monitoring command 369
- Multiple TN3270 ports 22

## N

- NCP
  - description of 234
- NCP configuration commands
  - purge 256
  - set 256
  - show 256

## NCP configuration commands *(continued)*

- show circuit 259
- summary of 247
- zero 265
- NCP monitoring commands
  - purge 256
  - set 256
  - show 256
  - show circuit 259
  - summary of 247
  - zero 265
- NDP
  - configuring 355
- NDP command 355
- NDP configuration commands
  - add 355
  - change 357
  - delete 358
  - disable 359
  - enable 359
  - list 359
  - summary 355
- NDP monitoring commands
  - accessing 359
  - dump 360
  - list 360
  - ping6 360
  - summary of 360
- neighbor
  - PIM monitoring command 370
- Network Control Protocols (NCP)
  - for PPP interfaces
    - AppleTalk Control Protocol 196
- node level parameter lists 48
- node tuning 39
- node types 1

## O

- Open System Interconnection (OSI)
  - address prefix encoding 279, 280
  - attached L2 IS routers 277
  - authentication passwords 280
  - designated IS 275
  - domain specific part (DSP) 269
  - end system (ES) 267
  - end system hello messages 281
  - ES-IS protocol 281
  - external routing 278
  - initial domain part (IDP) 268
    - description 268, 269
  - intermediate system (IS) 267
  - internal routing 278
  - IS hello messages 281
  - IS-IS addressing format 269
    - address format 270
    - AFI 280
    - area address 269
    - default address prefixes 280
    - fixed length IDI 279
    - non-pseudonode 276
    - point-to-point 275

Open System Interconnection (OSI) *(continued)*

IS-IS addressing format *(continued)*

pseudonode 276, 277  
selector 269  
system ID 269  
variable length IDI 280

IS-IS areas 271

IS-IS domain 272

IS to IS hello (IIH) messages 274, 275

L1 IIH message 274

L1 link state updates 276

L1 routing 277

L2 IIH messages 275

L2 link state updates 276, 277

L2 routing 278

link state databases 276

link state updates 276

multicast addresses 270

network address structure 268

network addresses 268

Network Entity Title (NET) 269

network protocol data units (NPDU) 267

NSAP addressing 268

protocols running under 268

pseudonode 275

routing metric 278

routing tables 277

synonymous areas 273

unattached L2 IS routers 277

optional features 6

OSI

configuring 283  
X.25 over OSI 289

OSI configuration commands

add 287  
change prefix address 293  
clear 295  
delete 296  
disable 298  
enable 299  
list 299  
set 305  
summary of 287

OSI/DECnet V

monitoring 287

OSI/DECnet V monitoring commands

addresses 312  
change metric 313  
clnp-stats 313  
designated-router 315  
DNAV-info 315  
es-adjacencies 316  
es-is-stats 316  
is-adjacencies 318  
is-is-stats 318  
l1-routes 320  
l1-summary 321  
l1-update 322  
l2-routes 320  
l2-summary 322  
l2-update 323

OSI/DECnet V monitoring commands *(continued)*

OSI/DECnet V monitoring command 315  
ping-1139 323  
route 324  
send (echo packet) 324  
subnets 325  
summary of 311  
toggle (alias/no alias) 325  
traceroute 325

## P

packet-filter

IPv6 monitoring command 351

packet size 383

path-mtu

IPv6 monitoring command 351

PIM

configuring 361

pim

PIM monitoring command 371

PIM command 361

PIM configuration commands

delete 361  
disable 362  
enable 362  
list 362  
set 363  
summary 361

PIM monitoring commands

accessing 365  
clear 366  
dump 366  
interface 367  
join 367  
leave 368  
mcache 368  
mggroup 368  
mstats 369  
neighbor 370  
pim 371  
ping 372  
summary of 366  
summary pim 372  
variables 373

ping

PIM monitoring command 372

ping-1139

OSI/DECnet V monitoring command 323

ping6

IPv6 monitoring command 351  
NDP monitoring command 360  
RIP6 monitoring command 382

Point-to-Point Protocol (PPP)

AppleTalk Control Protocol 196

port level parameter lists 48

port types supported 25

protocols

Digital Network Architecture (DNA) Phase IV 231

## R

- restart
  - APPN monitoring command 193
- restrictions 43
- RIP6
  - configuring 375
- RIP6 command 375
- RIP6 configuration commands
  - add 375
  - change 376
  - delete 377
  - disable 377
  - enable 378
  - list 380
  - set 380
  - summary 375
- RIP6 monitoring commands
  - accessing 381
  - dump 381
  - list 381
  - ping6 382
  - summary of 381
- route
  - IPv6 monitoring command 350
  - OSI/DECnet V monitoring command 324
- routing list 33
- RU size 39, 98

## S

- SDLC 62
  - APPN using 62
- Seed router
  - AppleTalk Phase 2 195, 198
- send (Echo Packet)
  - OSI/DECnet V monitoring command 324
- set
  - AppleTalk Phase 2 configuration command 209
  - APPN configuration command 81
  - IPv6 configuration command 341
  - OSI configuration command 305
  - PIM configuration command 363
  - RIP6 configuration command 380
  - VINES configuration command 226
- sizes
  - IPv6 monitoring command 350
- SNMP managed node, using the router as 19
- sphere of control 17
- static
  - IPv6 monitoring command 351
- stop
  - APPN monitoring command 193
- subnets
  - OSI/DECnet V monitoring command 325
- summary of
  - NCP configuration commands 247
  - NCP monitoring commands 247
- summary pim
  - PIM monitoring command 372
- supported message units 18
- supported message units, APPN-related alerts 18

## T

- talk
  - OPCON command 190, 333, 347, 355, 359, 361, 365, 375, 381
- TG characteristics 37
- the router as entry point 17
- TN3270 gateway function 20
- tn3270e
  - APPN monitoring command 193
- TN3270E Server 20, 24, 26
  - Client IP Address to LU Name Mapping 22
  - configuration commands 175
  - Configuration parameters 175
  - Configuring, using DLUR 71
  - Configuring, using local node identifier 75
  - How LUs are chosen for client connections 23
  - LU Pooling 21
  - monitoring commands 193
  - Multiple TN3270 ports 22
- toggle (Alias/No Alias)
  - OSI/DECnet V monitoring command 325
- Token-Ring 4/16
  - packet size 383
- topology Database Garbage Collection 19
- traceroute
  - IPv6 monitoring command 372
  - OSI/DECnet V monitoring command 325
- traceroute6
  - IPv6 monitoring command 352
- traces 39
- tracing 39
- transmission group characteristics, setting 37
- transmit
  - APPN monitoring command 194
- transporting data 44
- tunnels
  - IPv6 monitoring command 353

## U

- update
  - IPv6 configuration command 344

## V

- V.25 bis 60
- V.25bis
  - APPN using 60
- variables
  - PIM monitoring command 373
- VINES 225
  - Address Resolution Protocol (ARP) 220
  - basic configuration procedures 221
  - client nodes 215
  - configuring 215
  - disabling an interface 224
  - disabling globally 224
  - enabling an interface 225
  - enabling globally 225
  - monitoring 223

- VINES (*continued*)
  - monitoring commands 227
  - neighbor tables 219
    - dumping 228
    - setting size 226
  - network layer protocols 216
    - Address Resolution Protocol (ARP) 220
    - Internet Control Protocol (ICP) 220
    - Routing Update Protocol (RTP) 217
    - VINES IP 216
  - overview 215
  - routing tables 218
    - dumping 229
    - setting size 226
  - RTP implementation 219
  - service nodes 215
  - setting number of client nodes 226
- VINES configuration commands 223
- VINES monitoring commands
  - counters 227
  - dump 228
  - exit 230
- VTAM DSPU 10

## **W**

- WAN reroute 54
- WAN restoral 59





---

# Readers' Comments — We'd Like to Hear from You

Access Integration Services  
Protocol Configuration and Monitoring  
Reference Volume 2  
Version 3.2

Publication No. SC30-3991-00

Overall, how satisfied are you with the information in this book?

	Very Satisfied	Satisfied	Neutral	Dissatisfied	Very Dissatisfied
Overall satisfaction	<input type="checkbox"/>	<input type="checkbox"/>	<input type="checkbox"/>	<input type="checkbox"/>	<input type="checkbox"/>

How satisfied are you that the information in this book is:

	Very Satisfied	Satisfied	Neutral	Dissatisfied	Very Dissatisfied
Accurate	<input type="checkbox"/>	<input type="checkbox"/>	<input type="checkbox"/>	<input type="checkbox"/>	<input type="checkbox"/>
Complete	<input type="checkbox"/>	<input type="checkbox"/>	<input type="checkbox"/>	<input type="checkbox"/>	<input type="checkbox"/>
Easy to find	<input type="checkbox"/>	<input type="checkbox"/>	<input type="checkbox"/>	<input type="checkbox"/>	<input type="checkbox"/>
Easy to understand	<input type="checkbox"/>	<input type="checkbox"/>	<input type="checkbox"/>	<input type="checkbox"/>	<input type="checkbox"/>
Well organized	<input type="checkbox"/>	<input type="checkbox"/>	<input type="checkbox"/>	<input type="checkbox"/>	<input type="checkbox"/>
Applicable to your tasks	<input type="checkbox"/>	<input type="checkbox"/>	<input type="checkbox"/>	<input type="checkbox"/>	<input type="checkbox"/>

Please tell us how we can improve this book:

Thank you for your responses. May we contact you?  Yes  No

When you send comments to IBM, you grant IBM a nonexclusive right to use or distribute your comments in any way it believes appropriate without incurring any obligation to you.

---

Name

---

Address

---

Company or Organization

---

Phone No.



Fold and Tape

Please do not staple

Fold and Tape



NO POSTAGE  
NECESSARY  
IF MAILED IN THE  
UNITED STATES

# BUSINESS REPLY MAIL

FIRST-CLASS MAIL PERMIT NO. 40 ARMONK, NEW YORK

POSTAGE WILL BE PAID BY ADDRESSEE

IBM Corporation  
Design & Information Development  
Department CGF/Bldg. 656  
PO Box 12195  
Research Triangle Park, NC 27709-9990

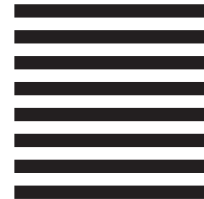

Fold and Tape

Please do not staple

Fold and Tape





Printed in the United States of America  
on recycled paper containing 10%  
recovered post-consumer fiber.

SC30-3991-00



Spine information:



Access Integration Services

AIS V3.2 Protocol Config Ref Vol 2

SC30-3991-00